

bilz

ThermoGrip®
Schrumpfspannfutter
Shrink Chucks





Liebe Leserin, lieber Leser,

an der „Schneide“ wird bekanntlich das Geld verdient. Dabei beeinflusst die Produktivität dieser Schneide die Gesamtkosten von Zerspanungsprozessen, zu denen sie selbst nur zwischen 4 – 6 % beiträgt. Diesen Aussagen werden wohl die Mehrzahl aller Produktions- und Zerspanungsfachleute zustimmen.

Doch was unternehmen Sie, um die Leistungsfähigkeit der Schneide voll auszunutzen und deren Standwege zu erhöhen?

Das vorliegende Handbuch soll Sie bei der Auswahl von optimalen Spannmitteln für Ihre „Schneiden“ unterstützen.

Unsere lange Erfahrung als traditionsreiches Familienunternehmen hilft uns dabei, Produkte zu entwickeln, denen Sie vertrauen können und in diesem Handbuch ein umfassendes Produktspektrum für Sie zusammenzustellen. Dabei sind zahlreiche Verbesserungen eingeflossen.



„Immer besser“ ist für uns kein Schlagwort. Es ist ein Qualitätsversprechen.

Und unsere Produkte und wir selbst halten, was wir versprechen.

Über das dargestellte Programm hinaus können wir Ihnen unterschiedlichste anwendungs-spezifische Lösungen anbieten.

Sprechen Sie uns auch für neue Lösungen gerne an.

Viele denken nach, wir denken gerne vor.

Im Namen des ganzen Bilz Teams



Dear reader,

As everyone knows, money is made at the „cutting edge“. The productivity of this cutting edge influences the total costs of cutting processes, however its contributions only amount to 4 – 6 %. Most production and cutting experts will agree with these statements.

What should you do to fully profit from the cutting edge performance and to increase tool life? This manual will support you in selecting the optimal clamping tools for your “cutting edges”.

Our long experience as a traditional family-run company helps us to develop products you can rely on and compile a comprehensive product range in this manual. Many improvements have been included.



“Always better” is not just a slogan for us. It is a promise for quality. We and our products keep our promises. Beyond this product range, we can offer you various custom-designed solutions. Please speak with us about new solutions for your applications.

Many people react, we act.

On behalf of the whole Bilz Team

T Schrumpffutter Standardausführung Shrink Chucks

HSK-A	Seite Page	HSK-C	Seite Page	HSK-E	Seite Page	HSK-F	Seite Page	CAT	Seite Page
HSK-A32	15	HSK-C32	32	HSK-E25	33	HSK-F40	41	CAT 40 Inch	48
HSK-A40	15	HSK-C40	32	HSK-E32	34	HSK-F63	42	CAT 40	49
HSK-A50	15	HSK-C50	32	HSK-E40	36	HSK-F63 Inch	43	CAT 50 Inch	50
HSK-A63	16	HSK-C63	32	HSK-E40 Inch	37			CAT 50	51
HSK-A63 Inch	19			HSK-E50	40				
HSK-A80	22			HSK-E50 Inch	41				
HSK-A80 Inch	22			HSK-E63	44				
HSK-A100	23								
HSK-A100 Inch	25								

AD	Seite Page	ADB/ADF	Seite Page	PSC	Seite Page
AD30	53	ADB40	56	PSC40	65
AD40	54	ADB50	58	PSC50	65
				PSC63	66
				PSC80	67

T Corona Jet 2.0

Schrumpffutter Shrink Chucks

C4-HSKA63	Seite Page
C4-HSKA63	18

TSF Schrumpffutter - Schlanke Ausführung Slim Shrink Chucks

HSK-A	Seite Page	HSK-E	Seite Page	HSK-F	Seite Page	AD	Seite Page	FBT	Seite Page
HSK-A63	20	HSK-E25	33	HSK-F40	45	AD40	57	FBT40	63
HSK-A63 Inch	21	HSK-E32	35						
		HSK-E32 Inch	35						
		HSK-E40	38						
		HSK-E40 Inch	39						
		HSK-E50	42						

THD Schrumpffutter - verstärkte Ausführung Heavy Duty Shrink Chucks

HSK-A	Seite Page	ADB/ADF	Seite Page	BT/JD	Seite Page	CAT	Seite Page
HSK-A100	30	ADB50	60	BT50	63	CAT40 Inch	52
HSK-A100 Inch	30						
HSK-A125	31					CAT50 Inch	52
HSK-A125 Inch	31						

T Cool Jet Schrumpffutter Shrink Chucks

HSK-A	Seite Page	AD40	Seite Page	ADF50	Seite Page
HSK-A63	17	AD40	55	ADF50	59
HSK-A100	24				

S Cool Jet

Schrumpffutter Shrink Chucks

PSC	Seite Page
PSC63	67

M Cool Jet Schrumpffutter Shrink Chucks

FBT30	Seite Page	FBT40	Seite Page	FBT50	Seite Page
FBT30	61	FBT40	62	FBT50	64

TB Schrumpffutter Shrink Chucks

HSK	Seite Page
HSK-A63, 100	26-29

TER Schrumpfeinsatz TER Shrink Fit Adaptor	TERV Schrumpfeinsatz TERV Shrink Fit Adaptor	Verlängerungen Extensions	Schwingungsgedämpfte Verl. Chuck Extensions with Vibration Damping	MMS MQL					
TER	Seite Page	TERV	Seite Page	TSFV	Seite Page	VIDAT	Seite Page	HSK-A	Seite Page
TER	75	TERV	77	110-160	69	LNE-T.,;20	72	MQ 1	81
TER Inch	76	TERV Inch	78	200-250	70	LNE-T.,;25	72	MQ 2	82-84
				110-250Inch	70	LNE-T.,;32	72		
						LNE-MH	72		

Hohe Laufruhe durch “Balanced by Design”
und anschließendem Feinwuchten

- Bessere Oberflächengüte
- Ideal für HPC/HSC Bearbeitung
- Schonung der Maschinenspindel

Optimized stability through “Balanced
by Design” and subsequent fine balancing

- Better surface quality
- Ideal for HPC/HSC processing
- Low wear of the machine spindle

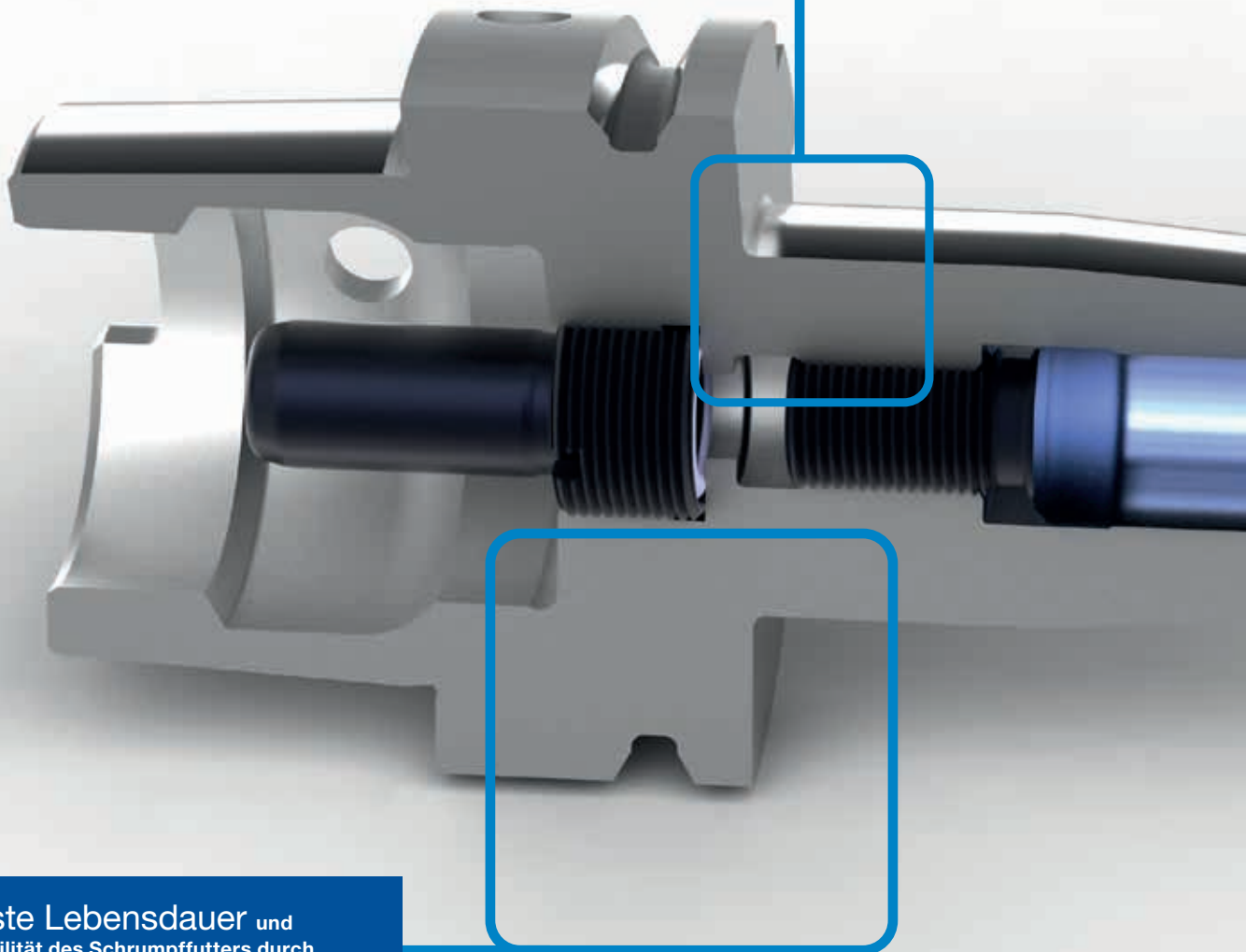

Höchste Lebensdauer und
Formstabilität des Schrumpffutters durch
Verwendung von hochwärmfestem Sonderstahl

- Hohe Radialsteifigkeit
- Geringe Auslenkung
- Hohe Zustellungen möglich

Longest tool life and form stability
due to the use of high heat resisting, special
purpose steel

- High radial rigidity
- Low deflection
- High rate of infeeds possible

Sicherheit

- Alle Zylinderschäfte nach DIN 1835 Form A, B und E sowie DIN 6535 Form HA, HB und HE können gespannt werden
- Kein Spannkraftverlust bei fettigen und öligen Schäften

Security

- All cylindrical shanks acc. to DIN 1835 Form A, B and E as well as DIN 6535 Form HA, HB and HE can be clamped
- No loss of clamping force on greasy and oily shanks

Patentierter Vorweite ermöglicht das Einsetzen des Werkzeugs im kalten Zustand sowie einen automatischen Schrumpfprozess und vereinfacht die Handhabung.
15% – 20% geringerer Wärmebedarf bei der Erhitzung des Schrumpffutters

The patented counterbore allows insertion of the tool under cold conditions, as well as an automatic shrinking process and simplified handling.
15% – 20% less heat required when heating the shrink chuck

Höchste Rundlaufgenauigkeit

< 0,003 mm und genaueste Kegeltoleranzen, hergestellt in klimatisierter Fertigung

- Reduzierung der Werkzeugkosten durch Standzeitverbesserung, da ein gleichmäßigerer Schneideneingriff erfolgt
- Reduzierung von Rattermarken

Highest concentricity

< 0,003 mm and precise taper tolerances, manufactured in an air-conditioned production area

- Reduced tool costs due to improved tool life, allows a constant cutting edge contact
- Reduced chatter marks

- **Vorzentrierung des Werkzeugs für einen automatisierten Schrumpfprozess**
- **15 % – 20 % geringerer Wärmebedarf bei der Erhitzung – materialschonend**
- **Optimales Ausschrumpfen von HSS Schäften**

- **Precentering of the tool for an automatic shrinking process**
- **15 % – 20 % less heat needed during heating – low wear**
- **Optimal shrinking out of HSS shanks**

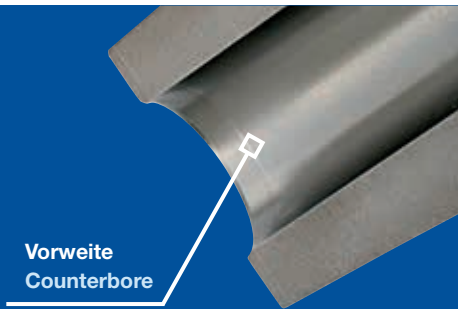

Die patentierte Bilz Vorweite erlaubt problemlose Werkzeugwechsel!
The patented Bilz counterbore allows problem free tool change

Hot Spot mit grafisch dargestellter Weitung
Hot Spot produces symmetric widening

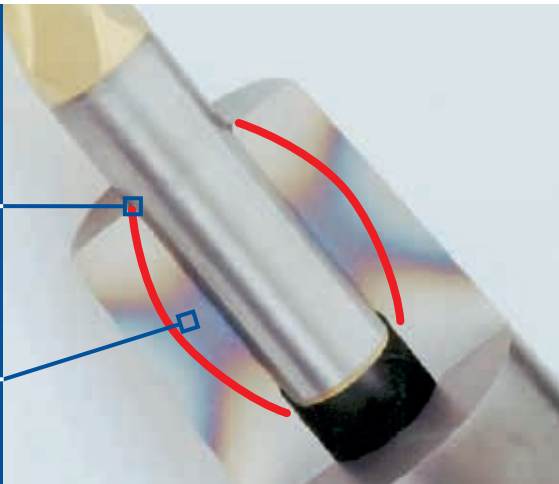

Infokasten Information

Das Bild oben zeigt einen Querschnitt eines induktiv erhitzten Schrumpffutters. In der Spulenmitte ist die Magnetfeldstärke am größten, weshalb sich dort die Futteroberfläche mehr als an den Randbereichen der Spule erwärmt. Durch diesen „Hot Spot“ ergibt sich eine unterschiedliche Temperatur entlang des Futter. Dadurch weitet sich das Futter um wenige Mikrometer in der Mitte stärker nach außen.

Das Futter ist somit am Hot Spot immer minimal mehr geöffnet als am Bohrungseingang. Die zylindrische Vorweite überbrückt diesen kritischen Punkt sicher bei reduziertem Energiebedarf. Diese materialschonende Erwärmung bewirkt eine längere Lebenszeit der Schrumpffutter.

The picture above shows the cross section of an inductively heated shrink chuck. The surface of the chuck mainly heats the Hot Spot area very quickly. This area is situated in the middle of the coil spindle. Since the temperature is always higher on the surface of the chuck than in the inner part, the chuck opens by micrometres – similar to a banana – slightly outwards.

Because of this, the chuck is always slightly more open at the Hot Spot than at the boring entry. The cylindrical counterbore bypasses this critical area securely at reduced energy requirement. Due to this low wear heating process, a longer tool life of the shrink chucks is guaranteed.

ThermoGrip® Schlanke Schrumpffutter

ThermoGrip® Slim Shrink Chucks



Speziell für den Gesenk- und Formenbau wurde die neue TSF ThermoGrip® Schrumpffutterserie (schlank) entwickelt.

Diese ist für das induktive Schrumpfen von Hartmetall-Werkzeugen geeignet. Durch die schlanke Bauform dieser neuen Schrumpffutterserie gehören Störkanten der Vergangenheit an. Die Außengeometrie der neuen TSF-Schrumpffutter wurde mit einer 3°-Schräge, passend für Formschrägen, ausgelegt.

Die schlanken Schrumpffutter sind zusätzlich mit einer nicht-rostenden Beschichtung ausgeführt.

Die TSF-Schrumpffutter haben eine Rundlaufgenauigkeit von < 0,003 mm und sind < 1 gmm/kg feingewuchtet. Speziell für diese Schrumpffutter werden in allen neuen Induktionsschrumpfgeräten der ThermoGrip® – Gerätefamilie die Parameter für Schrumpfzeit und Generatorleistung für den jeweils zu schrumpfenden Schaftdurchmesser hinterlegt. Bei älteren Geräteversionen können die Parameter nachgerüstet werden. Somit können auch diese sehr dünnwandigen Schrumpffutter prozesssicher gespannt und wieder gelöst werden, ohne sie dabei zu überhitzen.

Aus einer umfassenden Produktpalette für alle gängigen Werkzeugspindeln stehen verschiedene Nutzlängen für jeden Einsatzzweck zur Verfügung.

Introducing the new shrink chuck TSF ThermoGrip® – the slim version has been developed especially for the mold and die industry. This chuck type is used for induction shrinking of carbide tools. Due to the slim shape of this new chuck, interfering edges are a thing of the past.

The external geometry of the new shrink chuck TSF is designed with a 3° incline, compatible with dies and molds.

The slim shrink chucks have a non-corroding coating.

The chucks have a concentricity of < 0,003 mm and are fine balanced at < 1 gmm/kg. Specifically for these slim chucks, all new ThermoGrip® shrink units are programmed with the parameters of heating time and generator output to shrink all possible shank diameters. Older version shrink units can be upgraded with these parameters. As a result, thin-walled chucks can be shrunk with the highest reliability and without the risk of overheating.

The broad product range means that chucks with different lengths are available for all applications on all standard spindles.

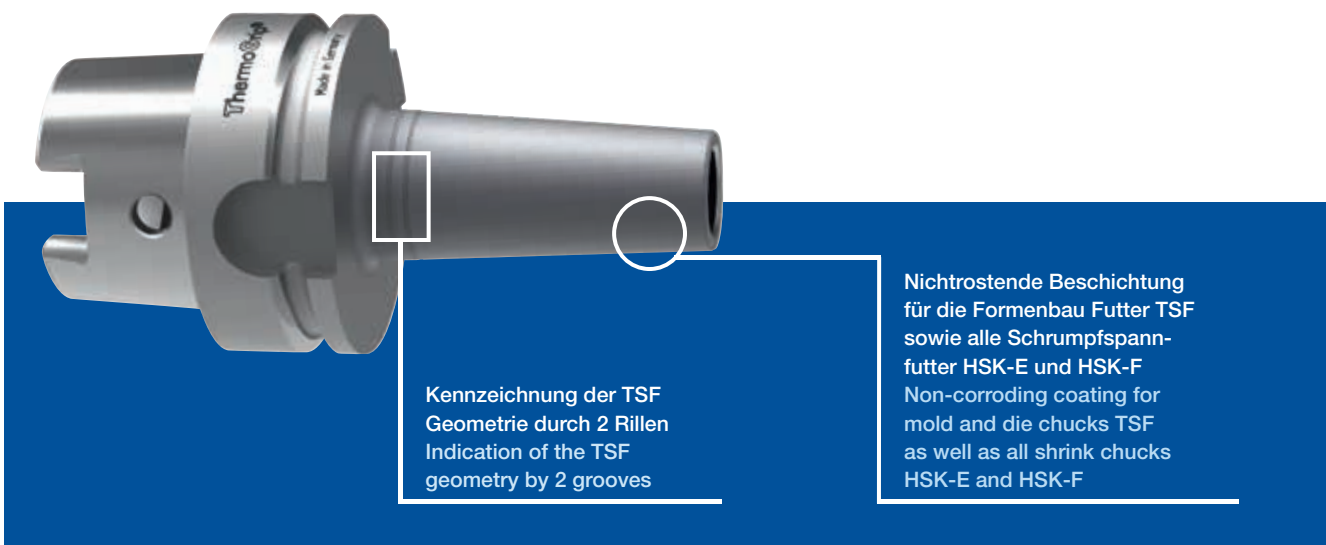



Die erhöhte Wandstärke, verbunden mit der verkürzten Bauform, hilft auch bei höchster Belastung Vibrationen zu vermeiden.
Increased wall thickness combined with the short and rigid design help prevent vibrations even at high speeds.

Hohe Radialsteifigkeit für beste Formgenauigkeit bei höchster Abtragate
High radial rigidity for best form stability at highest metal removal rate

Bis zu 50% mehr Überdeckung – Optimal für die *HPC Zerspanung

Hinweis: THD Futter erforderliche Geräte/Spulen:

Ø 16, 20, 25: auf ISG34xxWK-WS und Spule ISGS3200-2 möglich
Ø 32 und größer: nur auf HL-Geräten ISG44xx

Up to 50% more overlap – Suited for *HPC cutting

Attention: THD chuck can be used only with the following units/coils:

Ø 16, 20, 25: on ISG34xxWK-WS and coil ISGS3200-2 possible
Ø 32 and above: only on HL-units ISG44xx

* High Performance Cutting



ISG4410WK-HL

Der Schwergewichtsmeister – schrumpfen von Werkzeugen bis 40 kg
Vollautomatisches Schrumpfen und Kühlen auch großer und schwerer Schrumpffutter
Spannbereich Ø: 3 mm – 50 mm
Kühlart: Flüssigkeitskühlung
Kühlzeit: 30 Sekunden

The Heavyweight Champion - shrinking of tools up to 40 kg
Fully automatic Shrinking and Cooling, also suitable for large and heavy Shrink Chucks
Clamping range Ø: 3 mm – 50 mm
Cooling type: Water
Cooling time: 30 seconds

TSFV – Schlanke Schrumpferlängerungen
TSFV – Shrink Extensions



Optimale Kombination aus kleinstmöglicher Störkontur, hoher Radialsteifigkeit und hohen Drehmomenten
Optimal combination of the smallest possible interference contour, high radial rigidity, and high torques

Geeignet für den modularen Aufbau für tiefe, schwerzugängliche Kavitäten
Shanks for modular build up to access deep and restricted cavities



ThermoGrip® Cool Jet Anwendungen

Selbst bei schwierigsten Fräsoperationen arbeitet Thermogrip® Cool Jet aufgrund des auf die Schneide gerichteten Kühlmittelstrahls zuverlässig und sicher und wird durch die mitgelieferten Verschlusschrauben flexibel an die jeweilige Anwendung angepasst.

- alle Werkzeugtypen mit und ohne Innenkühlung
- universelle Eignung für alle Anwendungen im Metall,- Holz- und Verbundwerkstoff bereich

ThermoGrip® Cool Jet Applications

Even with the most difficult milling operations, Thermogrip® Cool Jet works reliably and safely due to the coolant jet directed to the cutting edge is flexibly adapted to each application due to the locking screws provided.

- all tool types with and without internal cooling
- universal suitability for all metal, wood and composite applications

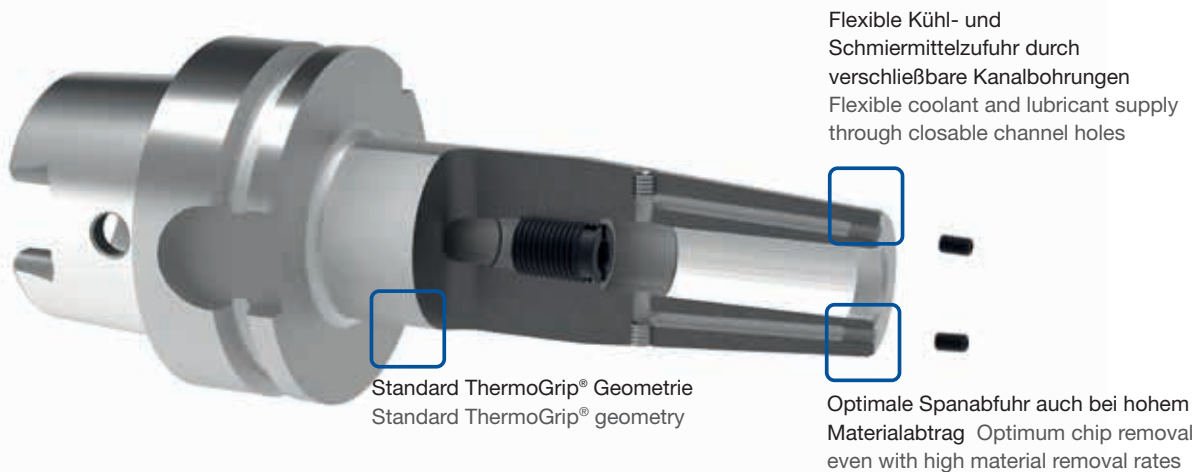

ThermoGrip® Cool Jet steht für flexible verschließbare Kühl- und Schmierstoffzufuhr

- bedarfsorientierte Kühlung der Schneide
- optimierte Luft- und Kühlschmierstoffzufuhr
- höhere Werkzeugstandzeiten durch konstante werkzeugschonende Temperaturen an der Schneide
- verbesserte Oberflächenqualität dank optimaler Spanabfuhr
- anwenderfreundliches Schrumpfen und Einsetzen

ThermoGrip® Cool Jet ist für Standardschrumpffuteraufnahmen T... von Durchmesser 3 mm bis 50 mm erhältlich

ThermoGrip® Cool Jet stands for optimised coolant supply through closable coolant supply channels

- demand-orientated cooling of the cutting edge
- optimized air and lubricant feed
- longer tool life due to constant tool preserving cutting temperatures at the cutting edge
- improved surface quality due to optimal chip removal – no second chip cutting
- excellent usability in shrinking and insertion

ThermoGrip® Cool Jet is available for standard shrink chuck shanks T... from diameter 3 mm up to 50 mm

ThermoGrip® Corona Jet 2.0 Anwendungen

Neuartige Kühlmittelzufuhr: Die Futterstirnseite besitzt einen Düsenring, dessen integrierte, in unterschiedlichen Winkeln angebrachten Düsen direkt auf die Schneide und die Spannuten ausgerichtet sind.

- für Werkzeuge ohne Kühlmittelkanäle
- Bearbeitung von Metall-, Holz- und Verbundwerkstoffen
- besonders bei Umfangfräsen, zirkulärem Taschenfräsen und tiefen Kavitäten

ThermoGrip® Corona Jet 2.0 Applications

Innovative Type of Coolant Feed: The front end of the chuck contains a jet ring with integrated jets set at varying angles, directed at the cutting edge and cutters flutes.

- for Tools without coolant channels
- Treatment of metal, wood and composites
- particularly suitable for peripheral milling, circular pocket milling and deep cavities



ThermoGrip® Corona Jet 2.0 steht für optimale Kühl- und Schmierstoffzufuhr direkt an die Werkzeugschneide

- verbesserte Oberflächenqualität dank optimaler Spanabfuhr
 - höhere Werkzeugstandzeiten durch konstante werkzeugschonende Temperaturen an der Schneide
 - komplette Kühlmittelbenetzung des Werkzeugs dank Düsenreihen in spezieller Winkelanordnung
 - Verringerung von Schneidenausbrüchen da kein Überfahren von Spänen
 - anwenderfreundliches Schrumpfen und Einsetzen
- ThermoGrip® Corona Jet ist für Standardschrumpffuteraufnahmen T... von Durchmesser 6 mm bis 20 mm erhältlich

ThermoGrip® Corona Jet 2.0 stands for optimal coolant and lubricant feed directly at the cutting edge

- improved surface quality due to optimal chip removal – No second cutting of chips
 - longer tool life due to constant tool cutting temperatures at the cutting edge
 - complete coolant spraying of the cutter due to the special angled design of the jets
 - reduction in tool breakage due to effective chip removal
 - excellent usability in shrinking and insertion
- ThermoGrip® Corona Jet is available for standard shrink chuck shanks T... from diameter 6 mm up to 20 mm

≤ 3 μm

Rundlaufgenauigkeit der ThermoGrip® Schrumpffutter
Concentricity of the ThermoGrip® Shrink Chucks

max. 8.000 max. 10.000 max. 12.000 max. 15.000 max. 18.000 max. 20.000 max. 24.000 max. 25.000 max. 30.000 max. 35.000 max. 36.000 max. 40.000 max. 42.000 max. 50.000

Max. zulässige Drehzahl Max. RPM

G2.5/25.000

Wuchtgüte: Die Futter sind werkseitig feingewuchtet mit G2,5 bei 25.000 U/min, bei Futter mit Masse > = 1 kg bzw. bei Futter mit Masse < 1 kg mit Restunwucht < 1 g mm
Balancing: The chucks are factory-made finely balanced with G2,5 at 25.000 rpm, for chucks with the mass of > = 1 kg; or chucks with the mass of < 1 kg with residual imbalance < 1 g mm

CHIP

Mit Datenträgerbohrung With data carrier bore

coated

Nichtrostend beschichtet Corrosion protected (coated)

Für tiefe Kavitäten geeignet – speziell für den Gesenk- und Formenbau
Suitable for deep cavities – especially for the mold and die industry

Vibrationsdämpfung Vibration damping

HSS

Geeignet für HSS Schäfte ab Durchmesser 6 mm Suitable for HSS shanks from diameter 6 mm

Für alle ThermoGrip® Schrumpffutter gilt:
Werkzeugschafttoleranzen: Ø 3,4 = h4 | Ø 5 = h5 | Ø ≥ 6 = h6

The following applies for all ThermoGrip® shrink chucks:
Shank tolerance: Ø 3,4 = h4 | Ø 5 = h5 | Ø ≥ 6 = h6

Formular Sonderschrumpffutter direkt per QR Code:
Form special shrink chuck directly via QR Code:

DE

EN

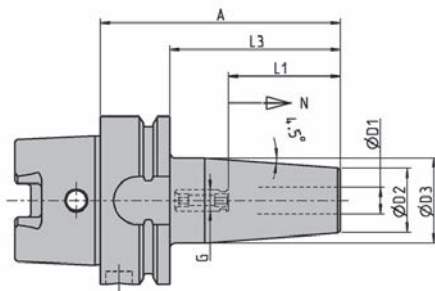

T... HSK-A32								G2,5/ 25.000	≤ 3µm	max. 40.000	CHIP	HSS
D1 [mm]	A [mm]	L3 [mm]	D2 [mm]	D3 [mm]	L1 [mm]	N [mm]	G	Bezeichnung Designation	Ident No.			
3	65	45	15	20	20	5	M6	T0300/HSK-A32	6727280			
4	65	45	15	20	20	5	M6	T0400/HSK-A32	6727281			
5	65	45	15	20	25	5	M6	T0500/HSK-A32	6727282			
6	75	55	21	26	36	10	M5	T0600-75/HSK-A32	5053729			
8	75	55	21	26	36	10	M6	T0800-75/HSK-A32	9129720			
10	75	55	24	29	42	10	M8x1	T1000/HSK-A32	6726214			
12	80	60	24	29	47	5	M10x1	T1200/HSK-A32	6726215			
		5064893				6738740		Zubehör, siehe Seite 91 Accessories, page 91				

T... HSK-A40								G2,5/ 25.000	≤ 3µm	max. 36.000	CHIP	HSS
D1 [mm]	A [mm]	L3 [mm]	D2 [mm]	D3 [mm]	L1 [mm]	N [mm]	G	Bezeichnung Designation	Ident No.			
3	60	40	15	20	20	5	M6	T0300/HSK-A40	6726615			
4	60	40	15	20	20	5	M6	T0400/HSK-A40	6726616			
5	60	40	15	20	25	5	M6	T0500/HSK-A40	6726617			
6	80	60	21	27	36	10	M5	T0600/HSK-A40	6726222			
8	80	60	21	27	36	10	M6	T0800/HSK-A40	6726223			
10	80	60	24	32	42	10	M8x1	T1000/HSK-A40	6726224			
12	90	70	24	32	47	10	M10x1	T1200/HSK-A40	6726225			
14	90	70	27	34	47	10	M10x1	T1400/HSK-A40	6726226			
16	90	70	27	34	50	10	M12x1	T1600/HSK-A40	6726227			
		5028425				6738741		Zubehör, siehe Seite 91 Accessories, page 91				

T... HSK-A50								G2,5/ 25.000	≤ 3µm	max. 30.000	CHIP	HSS
D1 [mm]	A [mm]	L3 [mm]	D2 [mm]	D3 [mm]	L1 [mm]	N [mm]	G	Bezeichnung Designation	Ident No.			
3	80	54	15	20	20	5	M6	T0300/HSK-A50	5038902			
4	80	54	15	20	20	5	M6	T0400/HSK-A50	9179308			
5	80	54	15	20	25	5	M6	T0500/HSK-A50	5000253			
6	80	54	21	27	36	10	M5	T0600/HSK-A50	6726232			
8	80	54	21	27	36	10	M6	T0800/HSK-A50	6726233			
10	85	59	24	32	42	10	M8x1	T1000/HSK-A50	6726234			
12	90	64	24	32	47	10	M10x1	T1200/HSK-A50	6726235			
14	90	64	27	34	47	10	M10x1	T1400/HSK-A50	6726236			
16	95	69	27	34	50	10	M12x1	T1600/HSK-A50	6726237			
18	95	69	33	42	50	10	M12x1	T1800/HSK-A50	6726238			
20	100	74	33	42	52	10	M16x1	T2000/HSK-A50	6726239			
		5028426				6738442		Zubehör, siehe Seite 91 Accessories, page 91				

T... HSK-A63, DIN 69893
Schrumpffutter Shrink Chucks

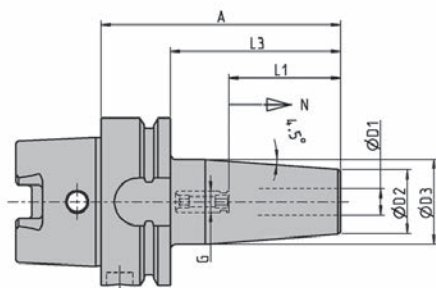

T... HSK - A63									G2,5/25.000	≤ 3µm	max. 24.000	CHIP	HSS
D1 [mm]	A [mm]	L3 [mm]	D2 [mm]	D3 [mm]	L1 [mm]	N [mm]	G	Bezeichnung Designation	Ident No.				
3	80	54	15	20	20	5	M6	T0300/HSK-A63	6726618				
4	80	54	15	20	20	5	M6	T0400/HSK-A63	6726619				
5	80	54	15	20	25	5	M6	T0500/HSK-A63	6726620				
6	80	54	21	27	36	10	M5	T0600/HSK-A63	6726201				
8	80	54	21	27	36	10	M6	T0800/HSK-A63	6726202				
10	85	59	24	32	42	10	M8x1	T1000/HSK-A63	6726203				
12	90	64	24	32	47	10	M10x1	T1200/HSK-A63	6726204				
14	90	64	27	34	47	10	M10x1	T1400/HSK-A63	6726205				
16	95	69	27	34	50	10	M12x1	T1600/HSK-A63	6726206				
18	95	69	33	42	50	10	M12x1	T1800/HSK-A63	6726211				
20	100	74	33	42	52	10	M16x1	T2000/HSK-A63	6726207				
25	115	89	44	52,5	58	10	M16x1	T2500/HSK-A63	6726208				
32	120	94	44	52,5	62	10	M16x1	T3200/HSK-A63	6726209				
6	120	94	21	27	36	10	M5	T0600-120/HSK-A63	6726388				
8	120	94	21	27	36	10	M6	T0800-120/HSK-A63	6726391				
10	120	94	24	32	42	10	M8x1	T1000-120/HSK-A63	6726392				
12	120	94	24	32	47	10	M10x1	T1200-120/HSK-A63	6726410				
14	120	94	27	34	47	10	M10x1	T1400-120/HSK-A63	6726401				
16	120	94	27	34	50	10	M12x1	T1600-120/HSK-A63	6726399				
18	120	94	33	42	50	10	M12x1	T1800-120/HSK-A63	6726539				
20	120	94	33	42	52	10	M16x1	T2000-120/HSK-A63	6726662				
25	120	94	44	52,5	58	10	M16x1	T2500-120/HSK-A63	6726416				
32	120	94	44	52,5	62	10	M16x1	T3200/HSK-A63	6726209				
6	160	134	21	32	36	10	M5	T0600-160/HSK-A63	6726411				
8	160	134	21	32	36	10	M6	T0800-160/HSK-A63	6726402				
10	160	134	24	34	42	10	M8x1	T1000-160/HSK-A63	6726403				
12	160	134	24	34	47	10	M10x1	T1200-160/HSK-A63	6726404				
14	160	134	27	42	47	10	M10x1	T1400-160/HSK-A63	6726405				
16	160	134	27	42	50	10	M12x1	T1600-160/HSK-A63	6726406				
18	160	134	33	51	50	10	M12x1	T1800-160/HSK-A63	6726407				
20	160	134	33	51	52	10	M16x1	T2000-160/HSK-A63	6726468				
25	160	134	44	52,5	58	10	M16x1	T2500-160/HSK-A63	6726408				
32	160	134	44	52,5	62	10	M16x1	T3200-160/HSK-A63	6726409				
6	200	174	21	32	36	10	M5	T0600-200-K1-HSKA63	6726634				
8	200	174	21	32	36	10	M6	T0800-200-K1-HSKA63	6726356				
10	200	174	24	34	42	10	M8x1	T1000-200-K1-HSKA63	6726498				
12	200	174	24	34	47	10	M10x1	T1200-200-K1-HSKA63	9073374				
14	200	174	27	42	47	10	M10x1	T1400-200-K1-HSKA63	5135423				
16	200	174	27	42	50	10	M12x1	T1600-200-K1-HSKA63	9079363				
18	200	174	33	51	50	10	M12x1	T1800-200-K1-HSKA63	5134245				
20	200	174	33	51	52	10	M16x1	T2000-200-K1-HSKA63	5066417				
25	200	174	44	52,5	58	10	M16x1	T2500-200-K1-HSKA63	5134246				
32	200	174	44	52,5	62	10	M16x1	T3200-200-K1-HSKA63	5134247				
	5025376			6738421		Zubehör, siehe Seite 91 Accessories, page 91							

T.....-C1-...HKA63 / Cool Jet, DIN69893

Cool Jet Schrumpffutter Shrink Chucks

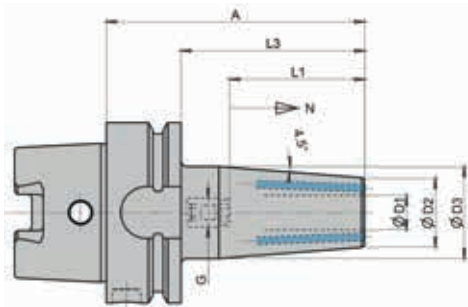

T.....-C1-HSKA63									G2.5/ 25.000	≤ 3µm	max. 24.000	CHIP	HSS
D1 [mm]	A [mm]	L3 [mm]	D2 [mm]	D3 [mm]	L1 [mm]	N [mm]	G	Bezeichnung Designation	Ident No.				
3	80	54	15	20	20	5	M6	T0300-80-C1-HSKA63	5150192				
4	80	54	15	20	20	5	M6	T0400-80-C1-HSKA63	5150201				
5	80	54	15	20	25	5	M6	T0500-80-C1-HSKA63	5147940				
6	80	54	21	27	36	10	M5	T0600-80-C1-HSKA63	5150210				
8	80	54	21	27	36	10	M6	T0800-80-C1-HSKA63	5150212				
10	85	59	24	32	42	10	M8 x1	T1000-85-C1-HSKA63	5150214				
12	90	64	24	32	47	10	M10 x1	T1200-90-C1-HSKA63	5150217				
14	90	64	27	34	47	10	M10 x1	T1400-90-C1-HSKA63	5150218				
16	95	69	27	34	50	10	M12 x1	T1600-95-C1-HSKA63	5150219				
18	95	69	33	42	50	10	M12 x1	T1800-95-C1-HSKA63	5150220				
20	100	74	33	42	52	10	M16 x1	T2000-100-C1-HSKA63	5150222				
25	115	89	44	52,5	58	10	M16 x1	T2500-115-C1-HSKA63	5150223				
32	120	94	44	52,5	62	10	M16 x1	T3200-120-C1-HSKA63	5150224				
6	120	94	21	27	36	10	M5	T0600-120-C1-HSKA63	5150225				
8	120	94	21	27	36	10	M6	T0800-120-C1-HSKA63	5150226				
10	120	94	24	32	42	10	M8 x1	T1000-120-C1-HSKA63	5150227				
12	120	94	24	32	47	10	M10 x1	T1200-120-C1-HSKA63	5150228				
14	120	94	27	34	47	10	M10 x1	T1400-120-C1-HSKA63	5150229				
16	120	94	27	34	50	10	M12 x1	T1600-120-C1-HSKA63	5150230				
18	120	94	33	42	50	10	M12 x1	T1800-120-C1-HSKA63	5150231				
20	120	94	33	42	52	10	M16 x1	T2000-120-C1-HSKA63	5150232				
25	120	94	44	52,5	58	10	M16 x1	T2500-120-C1-HSKA63	5150233				
32	120	94	44	52,5	62	10	M16 x1	T3200-120-C1-HSKA63	5150224				
6	160	134	21	32	36	10	M5	T0600-160-C1-HSKA63	5150235				
8	160	134	21	32	36	10	M6	T0800-160-C1-HSKA63	5150236				
10	160	134	24	34	42	10	M8 x1	T1000-160-C1-HSKA63	5150238				
12	160	134	24	34	47	10	M10 x1	T1200-160-C1-HSKA63	5150240				
14	160	134	27	42	47	10	M10 x1	T1400-160-C1-HSKA63	5150241				
16	160	134	27	42	50	10	M12 x1	T1600-160-C1-HSKA63	5150242				
18	160	134	33	51	50	10	M12 x1	T1800-160-C1-HSKA63	5150940				
20	160	134	33	51	52	10	M16 x1	T2000-160-C1-HSKA63	5150245				
25	160	134	44	52,5	58	10	M16 x1	T2500-160-C1-HSKA63	5150247				
32	160	134	44	52,5	62	10	M16 x1	T3200-160-C1-HSKA63	5150248				
		5025376				6738241		Zubehör, siehe Seite 91 Accessories, page 91					

Cool-Jet Ausführung

- für optional externe Kühlung
- 2 verschließbare Kühlkanalbohrungen
- optional mit 4 Kühlkanalbohrungen

Cool-Jet execution

- for optional external cooling
- 2 closable cooling channel holes
- Optionally with 4 cooling channel holes



*Hinweis Wuchtgüte siehe Seite 14 Balancing Information, page 14

T....-C4-HSKA63, DIN69892, Corona Jet 2.0 System
 Corona Jet Schrumpffutter Shrink Chucks

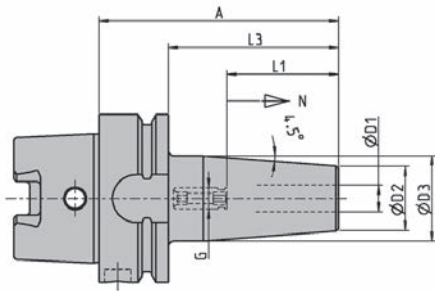

T....-C4-HSKA63

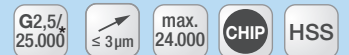

D1 (mm)	A (mm)	L3 (mm)	D2 (mm)	D3 (mm)	L1 (mm)	N (mm)	G	Bezeichnung Designation	Ident No.
6	80	54	21	27	36	10	M5	T0600-80-C4-HSKA63	5188357
8	80	54	21	27	36	10	M6	T0800-80-C4-HSKA63	5188358
10	85	59	24	32	42	10	M8x1	T1000-85-C4-HSKA63	5188359
12	90	64	24	32	47	10	M10x1	T1200-90-C4-HSKA63	5188360
14	90	64	27	34	47	10	M10x1	T1400-90-C4-HSKA63	5188361
16	95	69	27	34	50	10	M12x1	T1600-95-C4-HSKA63	5188362
18	95	69	33	42	50	10	M12x1	T1800-95-C4-HSKA63	5188363
20	100	74	33	42	52	10	M16x1	T2000-100-C4-HSKA63	5188364

Corona Jet 2.0 kann auf Anfrage optional nachgearbeitet werden.

Corona Jet 2.0 can be optionally reworked on request.

Ausführung inklusive CoronaJet Ring

Version includes Corona Jet ring

* A-Maß: 200 mm nicht möglich; A-Maß:160 mm auf Anfrage

* GPL: 200 mm not possible; GPL:160 mm on request

Zubehör: Düsenringe

Accessories: nozzle rings

Schaftdurchmesser Shank diameter (mm)	Anzugsmomente Tightening torques (Nm)	Ident No. Corona Jet Variante Corona Jet version	Ident No. Cool Jet Variante Cool Jet version	Ident No. Geschlossene Variante Closed version
6	20	5188400	5188519	5188527
8	24	5188401	5188520	5188528
10	28	5188402	5188521	5188529
12	32	5188404	5188522	5188530
14	36	5188405	5188523	5188531
16	40	5188406	5188524	5188532
18	44	5188407	5188525	5188533
20	48	5188408	5188526	5188534

Zubehör: Eindrehwerkzeug

Accessory: Ring assembly driver

Bezeichnung Designation	Aufnahme Shank	Ident No.
T-C4-0600-2000	1/2 Zoll □	5188546



Zubehör: Drehmomentschlüssel

Accessory: Torque wrench

Bezeichnung Designation	Aufnahme Shank	Ident No.
C4; Drehmomentschlüssel Torque wrench	1/2 Zoll □	5192155



T... HSK-A63, DIN 69893
 Shrunpfutter Shrink Chucks

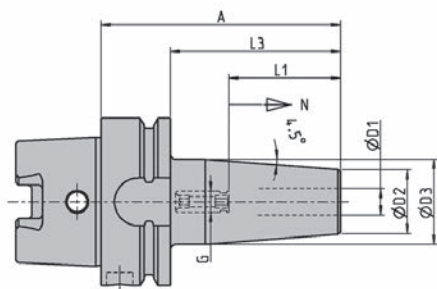

T... HSK-A63 – Inch									G2,5/25.000	≤ 3µm	max. 24.000	CHIP	HSS
D1 [Inch]	A [Inch]	L3 [Inch]	D2 [Inch]	D3 [Inch]	L1 [Inch]	N [Inch]	G	Bezeichnung Designation	Ident No.				
0,125	3,15	2,13	0,59	0,79	0,79	0,20	M6	T0318/HSK-A63	9079266				
0,187	3,15	2,13	0,59	0,79	0,98	0,20	M6	T0476/HSK-A63	9079278				
0,250	3,15	2,13	0,83	1,06	1,42	0,39	M5	T0635/HSK-A63	6726420				
0,312	3,15	2,13	0,83	1,06	1,42	0,39	M6	T0794/HSK-A63	6726421				
0,375	3,35	2,32	0,94	1,26	1,65	0,39	M8X1	T0953/HSK-A63	6726422				
0,500	3,54	2,52	1,06	1,34	1,85	0,39	M10X1	T1270/HSK-A63	6726424				
0,625	3,74	2,72	1,06	1,34	1,97	0,39	M12X1	T1588/HSK-A63	6726426				
0,750	3,94	2,91	1,30	1,65	2,05	0,39	M16X1	T1905/HSK-A63	6726428				
1,000	4,53	3,50	1,73	2,07	2,44	0,39	M16X1	T2540/HSK-A63	6726430				
0,125	4,72	3,70	0,59	0,79	0,79	0,20	M6	T0318-120/HSK-A63	9079267				
0,187	4,72	3,70	0,59	0,79	0,98	0,20	M6	T0476-120/HSK-A63	9079279				
0,250	4,72	3,70	0,83	1,06	1,42	0,39	M5	T0635-120/HSK-A63	6727392				
0,375	4,72	3,70	0,94	1,26	1,65	0,39	M8X1	T0953-120/HSK-A63	6727393				
0,500	4,72	3,70	1,06	1,34	1,85	0,39	M10X1	T1270-120/HSK-A63	6727394				
0,625	4,72	3,70	1,06	1,34	1,97	0,39	M12X1	T1588-120/HSK-A63	9079254				
1,000	4,72	3,70	1,73	2,07	2,44	0,39	M16X1	T2540-120/HSK-A63	5099442				
1,250	4,72	3,70	1,73	2,07	2,44	0,39	M16X1	T3175/HSK-A63	6726431				
0,125	6,30	5,28	0,59	1,06	0,79	0,20	M6	T0318-160/HSK-A63	9079268				
0,187	6,30	5,28	0,59	1,06	0,98	0,20	M6	T0476-160/HSK-A63	9079280				
0,250	6,30	5,28	0,83	1,26	1,42	0,39	M5	T0635-160/HSK-A63	6726614				
0,375	6,30	5,28	0,94	1,34	1,65	0,39	M8X1	T0953-160/HSK-A63	9079221				
0,500	6,30	5,28	1,06	1,65	1,85	0,39	M10X1	T1270-160/HSK-A63	9079247				
0,625	6,30	5,28	1,06	1,65	1,97	0,39	M12X1	T1588-160/HSK-A63	9079255				
0,750	6,30	5,28	1,30	2,01	2,05	0,39	M16X1	T1905-160/HSK-A63	9079258				
1,000	6,30	5,28	1,73	2,07	2,44	0,39	M16X1	T2540-160/HSK-A63	9079259				
1,250	6,30	5,28	1,73	2,07	2,44	0,39	M16X1	T3175-160/HSK-A63	9079261				
	5025376			6738421			Zubehör, siehe Seite 91 Accessories, page 91						



Coming soon
The new Bilz Shop.

Sie erreichen unseren neuen Shop bald unter
www.Bilz.de
You will reach the new shop under
www.Bilz.com



*Hinweis Wuchtgüte siehe Seite 14 Balancing Information, page 14

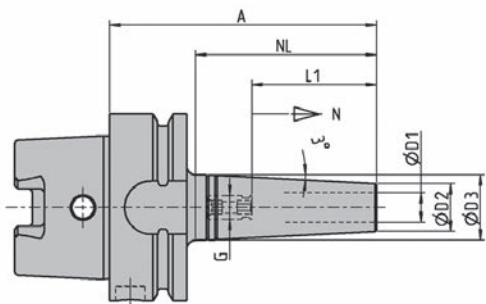

TSF... HSK-A63									G2,5/ 25.000	≤ 3µm	max. 24.000	CHIP	coated
D1 [mm]	A [mm]	NL [mm]	D2 [mm]	D3 [mm]	L1 [mm]	N [mm]	G	Bezeichnung Designation	Ident No.				
3	70	40	9	13	20	5	M6	TSF0300-40/HSK-A63	9078617				
4	70	40	10	14	20	5	M6	TSF0400-40/HSK-A63	9078654				
6	90	60	12	18	36	5	M5	TSF0600-60/HSK-A63	9078658				
8	90	60	14	20	36	5	M6	TSF0800-60/HSK-A63	9078670				
10	90	60	16	22	42	5	M8x1	TSF1000-60/HSK-A63	9078676				
12	90	60	18	24	47	5	M10x1	TSF1200-60/HSK-A63	9078725				
16	90	60	22	28	50	5	M12x1	TSF1600-60/HSK-A63	9078728				
3	100	70	9	16	20	5	M6	TSF0300-70/HSK-A63	9078652				
4	100	70	10	17	20	5	M6	TSF0400-70/HSK-A63	9078655				
6	120	90	12	21	36	5	M5	TSF0600-90/HSK-A63	9078660				
8	120	90	14	23	36	5	M6	TSF0800-90/HSK-A63	9078673				
10	120	90	16	25	42	5	M8x1	TSF1000-90/HSK-A63	9078677				
12	120	90	18	27	47	5	M10x1	TSF1200-90/HSK-A63	9078726				
16	120	90	22	31	50	5	M12x1	TSF1600-90/HSK-A63	9078729				
3	130	100	9	19	20	5	M6	TSF0300-100/HSK-A63	9078653				
4	130	100	10	20	20	5	M6	TSF0400-100/HSK-A63	9078657				
6	150	120	12	24	36	5	M5	TSF0600-120/HSK-A63	9078661				
8	150	120	14	26	36	5	M6	TSF0800-120/HSK-A63	9078674				
10	150	120	16	28	42	5	M8x1	TSF1000-120/HSK-A63	9078678				
12	150	120	18	30	47	5	M10x1	TSF1200-120/HSK-A63	9078624				
16	150	120	22	34	50	5	M12x1	TSF1600-120/HSK-A63	9078730				
3	200	174	9	26	20	5	M6	TSF0300-200-K1-HSKA63	5132995				
6	200	174	12	29	36	5	M6	TSF0600-200-K1-HSKA63	5132993				
8	200	174	14	31	36	5	M5	TSF0800-200-K1-HSKA63	5132996				
10	200	174	16	33	42	5	M8x1	TSF1000-200-K1-HSKA63	5132997				
12	200	174	18	35	47	5	M10x1	TSF1200-200-K1-HSKA63	5132999				
	TSF Wechselscheiben siehe Zubehör Seite 83 TSF discs, see accessories page 83												
	5025376		6738421	Zubehör, siehe Seite 91 Accessories, page 91									

TSF... HSK-A63, DIN69893
Schlanke Schrumpffutter Slim Shrink Chucks

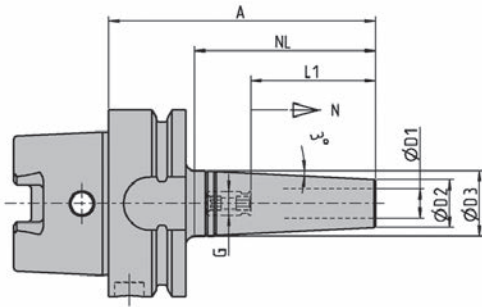

TSF... HSK-A63 – Inch



D1 [Inch]	A [Inch]	NL [Inch]	D2 [Inch]	D3 [Inch]	L1 [Inch]	N [Inch]	G	Bezeichnung Designation	Ident No.
0,125	2,76	1,57	0,35	0,51	0,79	0,20	M6	TSF0318-40/HSK-A63	5053808
0,187	3,54	2,36	0,43	0,71	0,98	0,20	M6	TSF0476-60/HSK-A63	5053812
0,250	3,54	2,36	0,47	0,71	1,42	0,20	M5	TSF0635-60/HSK-A63	5053814
0,375	3,54	2,36	0,63	0,87	1,65	0,20	M8X1	TSF0953-60/HSK-A63	5048183
0,500	3,54	2,36	0,79	1,02	1,85	0,20	M10X1	TSF1270-60/HSK-A63	5053816
0,625	3,54	2,36	0,87	1,10	1,97	0,20	M12X1	TSF1588-60/HSK-A63	5053817
0,125	3,94	2,76	0,35	0,63	0,79	0,20	M6	TSF0318-70/HSK-A63	5053818
0,187	4,72	3,54	0,43	0,83	0,98	0,20	M6	TSF0476-90/HSK-A63	5053819
0,250	4,72	3,54	0,47	0,83	1,42	0,20	M5	TSF0635-90/HSK-A63	5053821
0,375	4,72	3,54	0,63	0,98	1,65	0,20	M8X1	TSF0953-90/HSK-A63	5053822
0,500	4,72	3,54	0,79	1,14	1,85	0,20	M10X1	TSF1270-90/HSK-A63	5053823
0,625	4,72	3,54	0,87	1,22	1,97	0,20	M12X1	TSF1588-90/HSK-A63	5053824
0,125	5,12	3,94	0,35	0,75	0,79	0,20	M6	TSF0318-100/HSK-A63	5053825
0,187	5,91	4,72	0,43	0,94	0,98	0,20	M6	TSF0476-120/HSK-A63	5053826
0,250	5,91	4,72	0,47	0,94	1,42	0,20	M5	TSF0635-120/HSK-A63	5053827
0,375	5,91	4,72	0,63	1,10	1,65	0,20	M8X1	TSF0953-120/HSK-A63	5053828
0,500	5,91	4,72	0,79	1,26	1,85	0,20	M10X1	TSF1270-120/HSK-A63	5053829
0,625	5,91	4,72	0,87	1,34	1,97	0,20	M12X1	TSF1588-120/HSK-A63	5053830
TSF Wechselscheiben siehe Zubehör Seite 83 TSF discs, see accessories page 83									
5025376 6738421 Zubehör, siehe Seite 91 Accessories, page 91									

*Hinweis Wuchtgüte siehe Seite 14 Balancing Information, page 14

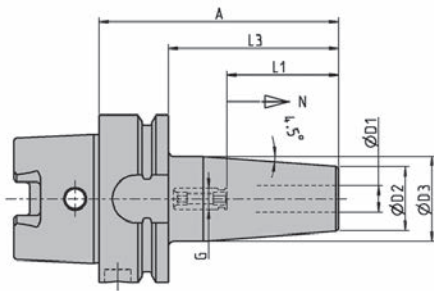

T... HSK - A80									G2,5/ 25.000	≤ 3µm	max. 12.000	CHIP	HSS
D1 [mm]	A [mm]	L3 [mm]	D2 [mm]	D3 [mm]	L1 [mm]	N [mm]	G	Bezeichnung Designation	Ident No.				
6	85	59	21	27	36	10	M5	T0600/HSK-A80	6726455				
8	85	59	21	27	36	10	M6	T0800/HSK-A80	6726396				
10	90	64	24	32	42	10	M8 x 1	T1000/HSK-A80	6726985				
12	95	69	24	32	47	10	M10 x 1	T1200/HSK-A80	6726397				
14	95	69	27	34	47	10	M10 x 1	T1400/HSK-A80	6727004				
16	100	74	27	34	50	10	M12 x 1	T1600/HSK-A80	6726658				
18	100	74	33	42	50	10	M12 x 1	T1800/HSK-A80	6726874				
20	105	79	33	42	52	10	M16 x 1	T2000/HSK-A80	6726659				
25	115	89	44	53	58	10	M16 x 1	T2500/HSK-A80	6726488				
32	120	94	44	53	62	10	M16 x 1	T3200/HSK-A80	6726882				
		5028427				6738095		Zubehör, siehe Seite 91 Accessories, page 91					

T... HSK - A80 - Inch									G2,5/ 25.000	≤ 3µm	max. 12.000	CHIP	HSS
D1 [Inch]	A [Inch]	L3 [Inch]	D2 [Inch]	D3 [Inch]	L1 [Inch]	N [Inch]	G	Bezeichnung Designation	Ident No.				
0,250	3,35	2,32	0,83	1,06	1,42	0,39	M5	T0635/HSK-A80	6726687				
0,375	3,54	2,52	0,94	1,26	1,65	0,39	M8X1	T0953/HSK-A80	6726688				
0,500	3,74	2,72	1,06	1,34	1,85	0,39	M10X1	T1270/HSK-A80	6726689				
0,625	3,94	2,91	1,06	1,34	1,97	0,39	M12X1	T1588/HSK-A80	6726690				
0,750	4,13	3,11	1,30	1,65	2,05	0,39	M16X1	T1905/HSK-A80	6726691				
1,000	4,53	3,50	1,73	2,09	2,44	0,39	M16X1	T2540/HSK-A80	6726692				
1,250	4,72	3,70	1,73	2,09	2,44	0,39	M16X1	T3175/HSK-A80	6726693				
		5028427				6738095		Zubehör, siehe Seite 91 Accessories, page 91					

T... HSK-A100, DIN 69893
Schrumpffutter Shrink Chucks

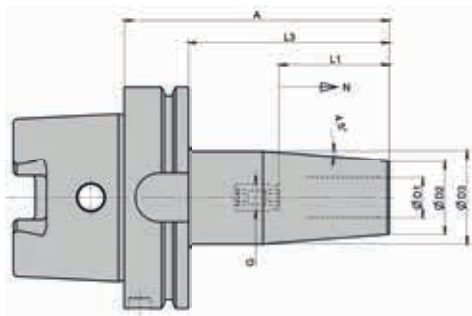

T... HSK - A 100								G2.5/ 25.000	≤ 3µm	max. 12.000	CHIP	HSS
D1 [mm]	A [mm]	L3 [mm]	D2 [mm]	D3 [mm]	L1 [mm]	N [mm]	G	Bezeichnung Designation	Ident No.			
6	85	56	21	27	36	10	M5	T0600/HSK-A100	6726342			
8	85	56	21	27	36	10	M6	T0800/HSK-A100	6726343			
10	90	61	24	32	42	10	M8x1	T1000/HSK-A100	6726344			
12	95	66	24	32	47	10	M10x1	T1200/HSK-A100	6726345			
14	95	66	27	34	47	10	M10x1	T1400/HSK-A100	6726346			
16	100	71	27	34	50	10	M12x1	T1600/HSK-A100	6726347			
18	100	71	33	42	50	10	M12x1	T1800/HSK-A100	6726348			
20	105	76	33	42	52	10	M16x1	T2000/HSK-A100	6726349			
25	115	86	44	53	58	10	M16x1	T2500/HSK-A100	6726350			
32	120	91	44	53	62	10	M16x1	T3200/HSK-A100	6726351			
6	120	91	21	27	36	10	M5	T0600-120/HSK-A100	6726478			
8	120	91	21	27	36	10	M6	T0800-120/HSK-A100	6726479			
10	120	91	24	32	42	10	M8x1	T1000-120/HSK-A100	6726755			
12	120	91	24	32	47	10	M10x1	T1200-120/HSK-A100	6726480			
14	120	91	27	34	47	10	M10x1	T1400-120/HSK-A100	6726833			
16	120	91	27	34	50	10	M12x1	T1600-120/HSK-A100	6726820			
18	120	91	33	42	50	10	M12x1	T1800-120/HSK-A100	6727035			
20	120	91	33	42	52	10	M16x1	T2000-120/HSK-A100	6726821			
25	120	91	44	53	58	10	M16x1	T2500-120/HSK-A100	6727037			
32	120	91	44	53	62	10	M16x1	T3200-120/HSK-A100	6726351			
6	160	131	21	32	36	10	M5	T0600-160/HSK-A100	6726645			
8	160	131	21	32	36	10	M6	T0800-160/HSK-A100	6726646			
10	160	131	24	34	42	10	M8x1	T1000-160/HSK-A100	6726647			
12	160	131	24	34	47	10	M10x1	T1200-160/HSK-A100	6726648			
14	160	131	27	42	47	10	M10x1	T1400-160/HSK-A100	6726649			
16	160	131	27	42	50	10	M12x1	T1600-160/HSK-A100	6726650			
18	160	131	33	51	50	10	M12x1	T1800-160/HSK-A100	6727036			
20	160	131	33	51	52	10	M16x1	T2000-160/HSK-A100	6726643			
25	160	131	44	60	58	10	M16x1	T2500-160/HSK-A100	6726644			
32	160	131	44	60	62	10	M16x1	T3200-160/HSK-A100	6727038			
6	200	171	21	32	36	10	M5	T0600-200-K1-HSK-A100	6727176			
8	200	171	21	32	36	10	M6	T0800-200-K1-HSK-A100	6727177			
10	200	171	24	34	42	10	M8x1	T1000-200-K1-HSK-A100	6727178			
12	200	171	24	34	47	10	M10x1	T1200-200-K1-HSK-A100	6727179			
14	200	171	27	42	47	10	M10x1	T1400-200-K1-HSK-A100	6727180			
16	200	171	27	42	50	10	M12x1	T1600-200-K1-HSK-A100	6727181			
18	200	171	33	51	50	10	M12x1	T1800-200-K1-HSK-A100	6727182			
20	200	171	33	51	52	10	M16x1	T2000-200-K1-HSK-A100	6727183			
25	200	171	44	60	58	10	M16x1	T2500-200-K1-HSK-A100	6727184			
32	200	171	44	60	62	10	M16x1	T3200-200-K1-HSK-A100	6727185			
		5028428				6738303		Zubehör, siehe Seite 91 Accessories, page 91				

*Hinweis Wuchtgüte siehe Seite 14 Balancing Information, page 14

T....-...-C1-...HSK-A100 / Cool Jet, DIN 69893

Cool Jet Schrumpffutter Shrink Chucks

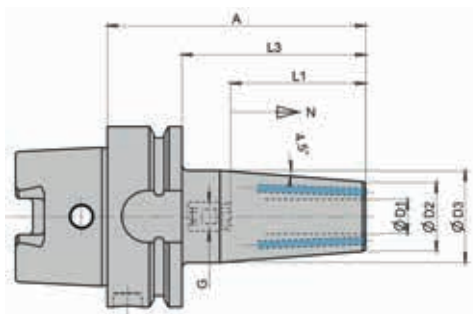

T....-...-C1-HSKA100									G2,5/ 25.000	≤ 3µm	max. 12.000	CHIP	HSS
D1 [mm]	A [mm]	L3 [mm]	D2 [mm]	D3 [mm]	L1 [mm]	N [mm]	G	Bezeichnung Designation	Ident No.				
6	85	56	21	27	36	10	M5	T0600-85-C1-HSKA100	5150254				
8	85	56	21	27	36	10	M6	T0800-85-C1-HSKA100	5150255				
10	90	61	24	32	42	10	M8 x1	T1000-90-C1-HSKA100	5150257				
12	95	66	24	32	47	10	M10 x1	T1200-95-C1-HSKA100	5150266				
14	95	66	27	34	47	10	M10 x1	T1400-95-C1-HSKA100	5150267				
16	100	71	27	34	50	10	M12 x1	T1600-100-C1-HSKA100	5150268				
18	100	71	33	42	50	10	M12 x1	T1800-100-C1-HSKA100	5150269				
20	105	76	33	42	52	10	M16 x1	T2000-105-C1-HSKA100	5150270				
25	115	86	44	53	58	10	M16 x1	T2500-115-C1-HSKA100	5150271				
32	120	91	44	53	62	10	M16 x1	T3200-120-C1-HSKA100	5150272				
6	120	91	21	27	36	10	M5	T0600-120-C1-HSKA100	5150279				
8	120	91	21	27	36	10	M6	T0800-120-C1-HSKA100	5150280				
10	120	91	24	32	42	10	M8 x1	T1000-120-C1-HSKA100	5150281				
12	120	91	24	32	47	10	M10 x1	T1200-120-C1-HSKA100	5150282				
14	120	91	27	34	47	10	M10 x1	T1400-120-C1-HSKA100	5150283				
16	120	91	27	34	50	10	M12 x1	T1600-120-C1-HSKA100	5150284				
18	120	91	33	42	50	10	M12 x1	T1800-120-C1-HSKA100	5150285				
20	120	91	33	42	52	10	M16 x1	T2000-120-C1-HSKA100	5150286				
25	120	91	44	53	58	10	M16 x1	T2500-120-C1-HSKA100	5150289				
32	120	91	44	53	62	10	M16 x1	T3200-120-C1-HSKA100	5150272				
6	160	131	21	32	36	10	M5	T0600-160-C1-HSKA100	5150295				
8	160	131	21	32	36	10	M6	T0800-160-C1-HSKA100	5150293				
10	160	131	24	34	42	10	M8 x1	T1000-160-C1-HSKA100	5150299				
12	160	131	24	34	47	10	M10 x1	T1200-160-C1-HSKA100	5150300				
14	160	131	27	42	47	10	M10 x1	T1400-160-C1-HSKA100	5150301				
16	160	131	27	42	50	10	M12 x1	T1600-160-C1-HSKA100	5150302				
18	160	131	33	51	50	10	M12 x1	T1800-160-C1-HSKA100	5150303				
20	160	131	33	51	52	10	M16 x1	T2000-160-C1-HSKA100	5150304				
25	160	131	44	60	58	10	M16 x1	T2500-160-C1-HSKA100	5150306				
32	160	131	44	60	62	10	M16 x1	T3200-160-C1-HSKA100	5150307				
		5028428			6738303	Zubehör, siehe Seite 91 Accessories, page 91							

Cool-Jet Ausführung

- für optional externe Kühlung
- 2 verschließbare Kühlkanalbohrungen
- optional mit 4 Kühlkanalbohrungen

Cool-Jet execution

- for optional external cooling
- 2 closable cooling channel holes
- Optionally with 4 cooling channel holes



T... HSK-A100, DIN 69893
 Schrumpffutter Shrink Chucks

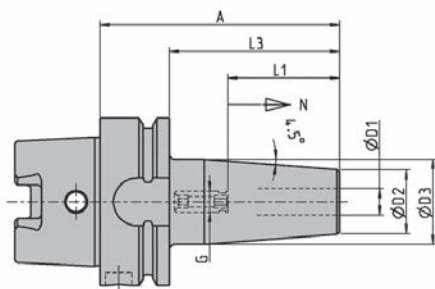

T... HSK-A 100 – Inch									G2,5/25.000	≤ 3µm	max. 12.000	CHIP	HSS
D1 [Inch]	A [Inch]	L3 [Inch]	D2 [Inch]	D3 [Inch]	L1 [Inch]	N [Inch]	G	Bezeichnung Designation	Ident No.				
0,250	3,35	2,20	0,83	1,06	1,42	0,39	M5	T0635/HSK-A100	6726432				
0,375	3,54	2,40	0,94	1,26	1,65	0,39	M8X1	T0953/HSK-A100	6726434				
0,500	3,74	2,60	1,06	1,34	1,85	0,39	M10X1	T1270/HSK-A100	6726436				
0,625	3,94	2,80	1,06	1,34	1,97	0,39	M12X1	T1588/HSK-A100	6726438				
0,750	4,13	2,99	1,30	1,65	2,05	0,39	M16X1	T1905/HSK-A100	6726497				
1,000	4,53	3,39	1,73	2,09	2,44	0,39	M16X1	T2540/HSK-A100	6726442				
0,250	4,72	3,58	0,83	1,06	1,42	0,39	M5	T0635-120/HSK-A100	5057074				
0,375	4,72	3,58	0,94	1,26	1,65	0,39	M8X1	T0953-120/HSK-A100	5057076				
0,500	4,72	3,58	1,06	1,34	1,85	0,39	M10X1	T1270-120/HSK-A100	5057079				
0,625	4,72	3,58	1,06	1,34	1,97	0,39	M12X1	T1588-120/HSK-A100	5057081				
0,750	4,72	3,58	1,30	1,65	2,05	0,39	M16X1	T1905-120/HSK-A100	5057083				
1,000	4,72	3,58	1,73	2,09	2,44	0,39	M16X1	T2540-120/HSK-A100	5057092				
1,250	4,72	3,58	1,73	2,09	2,44	0,39	M16X1	T3175/HSK-A100	6726444				
0,250	6,30	5,16	0,83	1,26	1,42	0,39	M5	T0635-160/HSK-A100	5057075				
0,375	6,30	5,16	0,94	1,34	1,65	0,39	M8X1	T0953-160/HSK-A100	5057077				
0,500	6,30	5,16	1,06	1,65	1,85	0,39	M10X1	T1270-160/HSK-A100	5057080				
0,625	6,30	5,16	1,06	1,65	1,97	0,39	M12X1	T1588-160/HSK-A100	5057082				
0,750	6,30	5,16	1,30	2,01	2,05	0,39	M16X1	T1905-160/HSK-A100	5057084				
1,000	6,30	5,16	1,73	2,36	2,44	0,39	M16X1	T2540-160/HSK-A100	5057093				
1,250	6,30	5,16	1,73	2,36	2,44	0,39	M16X1	T3175-160/HSK-A100	5057443				
		5028428				6738303		Zubehör, siehe Seite 91 Accessories, page 91					



Coming soon
The new Bilz Shop.

Sie erreichen unseren neuen Shop bald unter
www.Bilz.de
 You will reach the new shop under
www.Bilz.com

*Hinweis Wuchtgüte siehe Seite 14 Balancing Information, page 14

Formoptimierung zur Steigerung der Stabilität für maximale Biegesteifigkeit für größeres Zerspanungsvolumen

Form optimisation leads to an increase in the life and load capacity of the holder through a uniform structure throughout.

Die Tragstruktur unserer ThermoGrip® Bionic Schrumpffutter ist dem Wachstum von Bäumen nachempfunden. Dadurch wird Kerbspannung vermieden und trotzdem nur so viel Material eingesetzt, wie unbedingt nötig ist.

The bearing structure of our Thermogrip® Bionic shrink chucks has been designed based on the growth form of trees, meaning that notch stress is avoided and only as much material is used as is required.

Für unsere ThermoGrip® Schrumpfgeräte bestens geeignet

- Schrumpfbar mit Standardspule 1 bis Durchmesser 25 mm
- X-Parameter für das Ein- und Ausschrupfen

Perfectly suited for our Thermogrip® shrink machines

- Shrinkable with standard coil 1 up to diameter 25 mm
- Shrink machine X parameters for shrinking in and out

Hohe Laufruhe durch "Balanced by Design" und anschließendem Feinwuchten

- Bessere Oberflächengüte
- Ideal für HPC / HSC Bearbeitung
- Schonung der Maschinenspindel

Smooth, silent running due to

- "Balanced by Design" and subsequent fine balancing
- Improved surface quality = longer tool life, improved surface finish and better maintenance of tolerances
 - Ideal for HPC/HSC
 - Protection for the machine spindle

Datenträgerbohrung (HSKA)
Data Chip holes (HSKA)

Höchste Formstabilität und Lebensdauer des Schrumpffutters durch Verwendung von hochwarmfestem Sonderstahl

- Hohe Radialsteifigkeit
- Geringe Auslenkung
- Hohe Zustellungen möglich

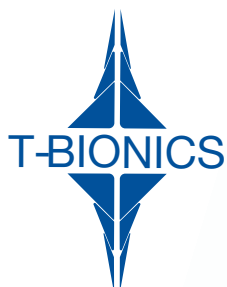

Merkmale

- Maximale Biegesteifigkeit durch bionische Kontur
- Vorweite – das ThermoGrip® Markenzeichen
- Standardmäßig mit verschleißbaren Cool Jet Kühlmittelbohrungen zur Peripheriekühlung und Bohrungen für Wuchtschrauben zur Feinwuchtung
- Rundlaufgenauigkeit < 3 µm

Features

- Maximum bending strength due to the bionic contour
- Increased rigidity
- Counterbore – the Thermogrip® trademark
- Improved surface quality due to optimal chip removal
- Run-out quality < 3µm

Nutzen

- Höhere Vorschübe und größere Spantiefe
- Erhöhte Drehmomentübertragungen
- Verbesserte Oberflächenqualität dank optimaler Spanabfuhr

Benefits

- Higher feed rates and greater cutting depth
- Increased torque transmission
- Lockable Cool Jet holes for peripheral cooling and balance screw holes for fine balancing as standard

bilz

HSK

CAT

AD/ADF

JD/JDF/BT/FBT

PSC

TSFV

LNE/VIDAT

TER/TERV

MMS/MQL

Appendix

Sicherheit

- Alle Zylinderschäfte nach DIN 1835 Form A,B und E sowie DIN 6535 Form HA, HB und HE können gespannt werden.

Security

- All cylindrical shanks manufactured to DIN1835 Form A, B and E, DIN 6535 Form HA, HB and HE can be used

Gewindebohrungen

zum Feinwuchten mit Wuchtschrauben

Tapped holes

For fine balancing with balancing screws

Patentierte Vorweite

ermöglicht das Einsetzen des Werkzeugs im kalten Zustand sowie einen automatischen Schrumpfprozess und vereinfacht die Handhabung.

15% – 20% geringerer Wärmebedarf bei der Erhitzung des Schrumpffutters

The patented counterbore

makes it possible for the tool to be inserted cold so that the shrinking process can be carried out fully automatically and thereby simplifies handling and improves user safety.

15 – 20 % reduction in heat requirements when heating the shrink chuck

Cool-Jet Kühlmittelbohrungen

(verschließbar)

Cool-Jet holes (lockable)

Höchste Rundlaufgenauigkeit

< 0,003 mm und genaueste Kegeltoleranzen, hergestellt in klimatisierter Fertigung

- Reduzierung der Werkzeugkosten durch Standzeitverbesserung, da ein gleichmäßigerer Schneideneingriff erfolgt
- Reduzierung von Rattermarken

Maximum Concentricity

< 0,003 mm and exact taper tolerances, manufactured in a climate-controlled environment

- Reduction of production costs due to a smoother cutting process leading to improved tool life.
- Reduction of chatter marks
- Increased tool life
- Better surface finish quality
- Maintenance of tolerances for longer

Maximum form stability

and life of the shrink chuck due to the use of high temperature resistant special steel

- High radial rigidity
- Low deflection
- High metal removal rates

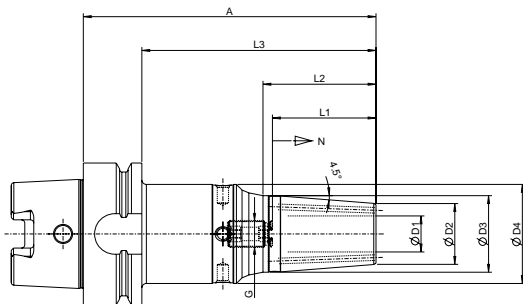

TB.....-C1-HSKA63											G2,5/ 25.000	≤ 3µm	max. 12.000	CHIP	HSS
Schrumpffutter Shrink Chucks											Bezeichnung Designation		Ident No.		
D1 (mm)	D2 (mm)	D3 (mm)	D4 (mm)	A (mm)	L1 (mm)	L2 (mm)	L3 (mm)	N (mm)	G						
6	21	27	37	130	36	41	104	10	M5	TB0600-130-C1-HSKA63	5177818				
8	21	27	37	130	36	41	104	10	M6	TB0800-130-C1-HSKA63	5177820				
10	24	32	42	130	42	53	104	10	M8x1	TB1000-130-C1-HSKA63	5177823				
12	24	32	42	130	47	53	104	10	M10x1	TB1200-130-C1-HSKA63	5177829				
14	27	34	44	130	47	50	104	10	M10x1	TB1400-130-C1-HSKA63	5177832				
16	27	34	44	130	50	50	104	10	M12x1	TB1600-130-C1-HSKA63	5177835				
18	33	42	52	130	50	60	104	10	M12x1	TB1800-130-C1-HSKA63	5177838				
20	33	42	52	130	52	60	104	10	M16x1	TB2000-130-C1-HSKA63	5177841				
6	21	27	42	160	36	40	134	10	M5	TB0600-160-C1-HSKA63	5177817				
8	21	27	42	160	36	40	134	10	M6	TB0800-160-C1-HSKA63	5177816				
10	24	32	47	160	42	52	134	10	M8x1	TB1000-160-C1-HSKA63	5177826				
12	24	32	47	160	47	52	134	10	M10x1	TB1200-160-C1-HSKA63	5177830				
14	27	34	50	160	47	50	134	10	M10x1	TB1400-160-C1-HSKA63	5177833				
16	27	34	50	160	50	50	134	10	M12x1	TB1600-160-C1-HSKA63	5177836				
18	33	42	52	160	50	60	134	10	M12x1	TB1800-160-C1-HSKA63	5177839				
20	33	42	52	160	52	60	134	10	M16x1	TB2000-160-C1-HSKA63	5177842				

TB.....-C1-HSKA100 / T-Bionics, DIN 69893
T-Bionics Schrumpffutter Shrink Chucks



HSK



Bild 1
Image 1



Bild 2
Image 2

CAT

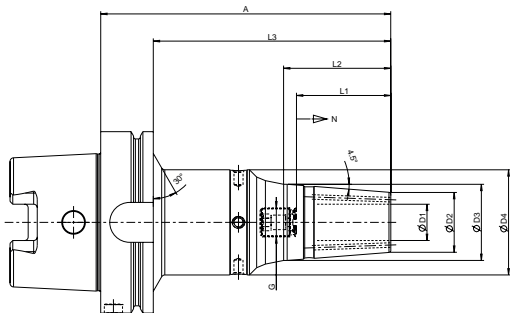
AD/ADF

TB.....-C1-HSKA100
Schrumpffutter Shrink Chucks

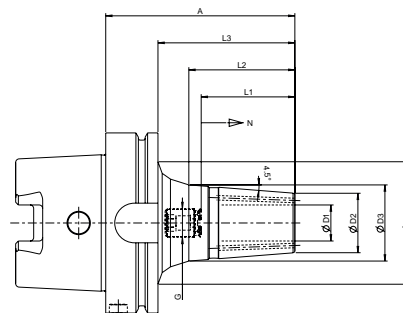

D1 (mm)	D2 (mm)	D3 (mm)	D4 (mm)	A (mm)	L1 (mm)	L2 (mm)	L3 (mm)	N (mm)	G	Bild Image	Bezeichnung Designation	Ident No.
6	21	27,1	50	85	36	39,1	56	10	M5	2	TB0600-85-C1-HSKA100	5180065
8	21	27,1	50	85	36	39,1	56	10	M6	2	TB0800-85-C1-HSKA100	5180066
10	24	32,1	50	90	42	51,4	61	10	M8x1	2	TB1000-90-C1-HSKA100	5180067
12	24	32,3	50	95	47	52,9	66	10	M10x1	2	TB1200-95-C1-HSKA100	5180068
14	27	34,1	62	95	47	45,3	66	10	M10x1	2	TB1400-95-C1-HSKA100	5180069
16	27	34,2	68	100	50	46	71	10	M12x1	2	TB1600-100-C1-HSKA100	5180074
18	33	42,1	68	100	50	57,7	71	10	M12x1	2	TB1800-100-C1-HSKA100	5180075
20	33	42,3	68	105	52	58,9	76	10	M16x1	2	TB2000-105-C1-HSKA100	5180077
25	44	53,4	85	115	58	59,9	86	10	M16x1	2	TB2500-115-C1-HSKA100	5180078
6	21	27	42	160	36	40	131	10	M5	1	TB0600-160-C1-HSKA100	5180079
8	21	27	42	160	36	40	131	10	M6	1	TB0800-160-C1-HSKA100	5180080
10	24	32	47	160	42	52	131	10	M8x1	1	TB1000-160-C1-HSKA100	5180081
12	24	32	47	160	47	52	131	10	M10x1	1	TB1200-160-C1-HSKA100	5180082
14	27	34	50	160	47	50	131	10	M10x1	1	TB1400-160-C1-HSKA100	5180083
16	27	34	50	160	50	50	131	10	M12x1	1	TB1600-160-C1-HSKA100	5180084
18	33	42	58	160	50	59	131	10	M12x1	1	TB1800-160-C1-HSKA100	5180085
20	33	42	58	160	52	59	131	10	M16x1	1	TB2000-160-C1-HSKA100	5180086
25	44	52,5	68	160	58	59	131	10	M16x1	1	TB2500-160-C1-HSKA100	5180087

JD/JDF/BT/FBT

PSC

TSFV

LNE/VIDAT

TER/TERV

MMS/MQL

*Hinweis Wuchtgüte siehe Seite 14 Balancing Information, page 14

Appendix

THD... HSK-A100, DIN 69893

Verstärkte Schrumpffutter Heavy Duty Shrink Chucks

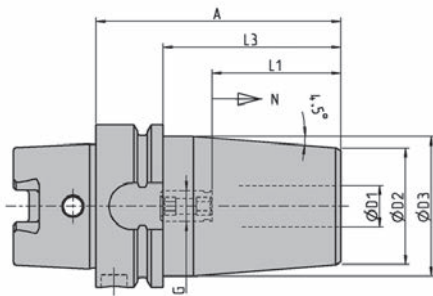

THD... HSK - A 100									G2,5/ 25.000	≤ 3µm	max. 12.000	CHIP	HSS
D1 [mm]	A [mm]	L3 [mm]	D2 [mm]	D3 [mm]	L1 [mm]	N [mm]	G	Bezeichnung Designation	Ident No.				
16	105	76	50	61	50	10	M12x1	THD1600-105/HSK-A100	5029007				
20	110	81	58	70	52	10	M16x1	THD2000-110/HSK-A100	5025872				
25	110	81	64	76	58	10	M16x1	THD2500-110/HSK-A100	5026038				
32	120	91	72	85	62	10	M16x1	THD3200-120/HSK-A100	5028982				
		5028428				6738303		Zubehör, siehe Seite 91 Accessories, page 91					
Hinweis zu THD Futter siehe Seite 10 Note for THD chucks, have a look at page 10													

THD... HSK - A100 – Inch									G2,5/ 25.000	≤ 3µm	max. 12.000	CHIP	HSS
D1 [Inch]	A [Inch]	L3 [Inch]	D2 [Inch]	D3 [Inch]	L1 [Inch]	N [Inch]	G	Bezeichnung Designation	Ident No.				
0,625	4,13	2,99	1,97	2,40	1,97	0,39	M12X1	THD1588-105/HSK-A100	5054390				
0,750	4,33	3,19	2,28	2,76	2,05	0,39	M16X1	THD1905-110/HSK-A100	5054391				
1,000	4,72	3,58	2,52	2,99	2,28	0,39	M16X1	THD2540-120/HSK-A100	5054392				
1,250	4,72	3,58	2,83	3,35	2,44	0,39	M16X1	THD3175-120/HSK-A100	5054393				
		5028428				6738303		Zubehör, siehe Seite 91 Accessories, page 91					
Hinweis zu THD Futter siehe Seite 10 Note for THD chucks, have a look at page 10													

THD... HSK-A125, DIN 69893

Verstärkte Schrumpffutter Heavy Duty Shrink Chucks

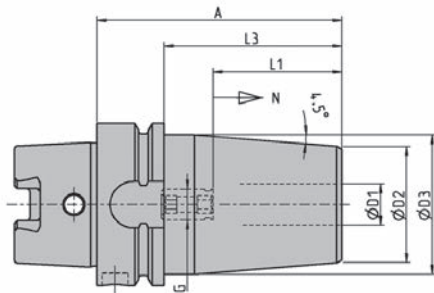

THD... HSK - A 125								G2,5/ 25.000	≤ 3µm	max. 10.000	CHIP	HSS
D1 [mm]	A [mm]	L3 [mm]	D2 [mm]	D3 [mm]	L1 [mm]	N [mm]	G	Bezeichnung Designation	Ident No.			
16	110	81	50	60	50	10	M12x1	THD1600-110/HSK-A125	5029874			
20	115	86	58	68	52	10	M16x1	THD2000-115/HSK-A125	5031102			
25	120	91	64	76	58	10	M16x1	THD2500-120/HSK-A125	5029870			
32	125	96	72	85	62	10	M16x1	THD3200-125/HSK-A125	5031105			
		5081044						Zubehör, siehe Seite 91 Accessories, page 91				

Hinweis zu THD Futter siehe Seite 10 Note for THD chucks, have a look at page 10

THD... HSK - A125 - Inch								G2,5/ 25.000	≤ 3µm	max. 10.000	CHIP	HSS
D1 [Inch]	A [Inch]	L3 [Inch]	D2 [Inch]	D3 [Inch]	L1 [Inch]	N [Inch]	G	Bezeichnung Designation	Ident No.			
0,625	4,33	3,19	1,97	2,36	1,97	0,39	M12X1	THD1588-110/HSK-A125	5054394			
0,750	4,53	3,39	2,28	2,68	2,05	0,39	M16X1	THD1905-115/HSK-A125	5054395			
1,000	4,92	3,78	2,52	2,99	2,28	0,39	M16X1	THD2540-125/HSK-A125	5054396			
1,250	4,92	3,78	2,83	3,35	2,44	0,39	M16X1	THD3175-125/HSK-A125	5054397			
		5081044						Zubehör, siehe Seite 91 Accessories, page 91				

Hinweis zu THD Futter siehe Seite 10 Note for THD chucks, have a look at page 10

*Hinweis Wuchtgüte siehe Seite 14 Balancing Information, page 14

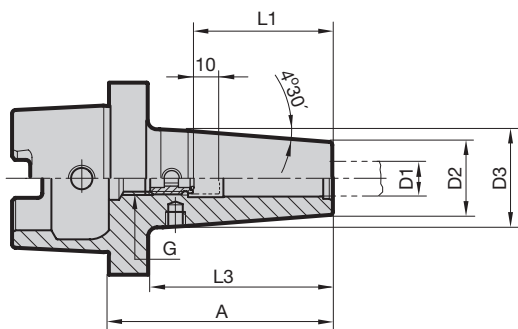

T... HSK - C32 G2,5/
25.000 ≤ 3µm max.
25.000 HSS

D1 [mm]	A [mm]	D2 [mm]	D3 [mm]	L1 [mm]	L3 [mm]	G	Bezeichnung Designation	Ident No.
6	65	21	26	36	55	M5	T0600-65-K1-HSKC32-S	5072296
8	65	21	26	36	55	M6	T0800-65-K1-HSKC32-S	5072304
10	65	24	30	41	55	M8x1	T1000-65-K1-HSKC32-S	5072305
12	75	24	32	46	65	M10x1	T1200-75-K1-HSKC32-S	5072307

T... HSK - C40 G2,5/
25.000 ≤ 3µm max.
25.000 HSS

D1 [mm]	A [mm]	D2 [mm]	D3 [mm]	L1 [mm]	L3 [mm]	G	Bezeichnung Designation	Ident No.
6	70	21	30	36	60	M5	T0600-70-K1-HSKC40-S	5072308
8	70	21	30	36	60	M6	T0800-70-K1-HSKC40-S	5072309
10	70	24	33,5	41	60	M8x1	T1000-70-K1-HSKC40-S	5072310
12	80	24	35	46	70	M10x1	T1200-80-K1-HSKC40-S	5072311
14	80	27	38	46	70	M10x1	T1400-80-K1-HSKC40-S	5072318
16	80	27	38	49	70	M12x1	T1600-80-K1-HSKC40-S	5072319

T... HSK - C50 G2,5/
25.000 ≤ 3µm max.
25.000 HSS

D1 [mm]	A [mm]	D2 [mm]	D3 [mm]	L1 [mm]	L3 [mm]	G	Bezeichnung Designation	Ident No.
6	70	21	30	36	57,5	M5	T0600-70-K1-HSKC50-S	5072320
8	70	21	30	36	57,5	M6	T0800-70-K1-HSKC50-S	5072321
10	75	24	33	41	62,5	M8x1	T1000-75-K1-HSKC50-S	5072322
12	80	24	34	46	67,5	M10x1	T1200-80-K1-HSKC50-S	5072325
14	80	27	37	46	67,5	M10x1	T1400-80-K1-HSKC50-S	5072326
16	85	27	38,5	49	72,5	M12x1	T1600-85-K1-HSKC50-S	5072327
18	85	33	44,5	49	72,5	M12x1	T1800-85-K1-HSKC50-S	5072328
20	90	33	45	51	77,5	M16x1	T2000-90-K1-HSKC50-S	5072329

T... HSK - C63 G2,5/
25.000 ≤ 3µm max.
25.000 HSS

D1 [mm]	A [mm]	D2 [mm]	D3 [mm]	L1 [mm]	L3 [mm]	G	Bezeichnung Designation	Ident No.
6	70	21	30	36	57,5	M5	T0600-70-K1-HSKC63-S	5072330
8	70	21	30	36	57,5	M6	T0800-70-K1-HSKC63-S	5072331
10	75	24	34	41	62,5	M8x1	T1000-75-K1-HSKC63-S	5072332
12	80	24	34	46	67,5	M10x1	T1200-80-K1-HSKC63-S	5072333
14	80	27	36	46	67,5	M10x1	T1400-80-K1-HSKC63-S	5072334
16	85	27	36	49	72,5	M12x1	T1600-85-K1-HSKC63-S	5072335
18	85	33	44	49	72,5	M12x1	T1800-85-K1-HSKC63-S	5072336
20	90	33	45	51	77,5	M16x1	T2000-90-K1-HSKC63-S	5072337
25	100	44	53	57	87,5	M16x1	T2500-100-K1-HSKC63-S	5072338
32	110	44	53	61	97,5	M16x1	T3200-110-K1-HSKC63-S	5072662

T... HSK-E25, DIN 69893
Schrumpffutter Shrink Chucks

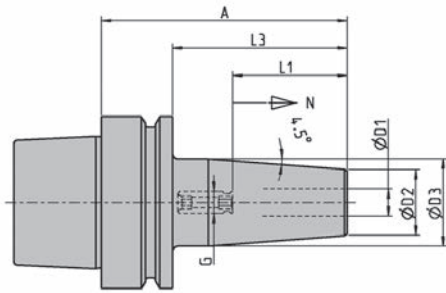

T... HSK - E25									G2,5/ 25.000	≤ 3µm	max. 50.000	HSS
D1 [mm]	A [mm]	L3 [mm]	D2 [mm]	D3 [mm]	L1 [mm]	N [mm]	G	Bezeichnung Designation	Ident No.			
6	50	40	15	19	36	5	M5	T0600/HSK-E25	9091169			
6	55	45	15	19	36	5	M5	T0600-55/HSK-E25	5023504			
		5100005				5100007		Zubehör, siehe Seite 91 Accessories, page 91				

TSF... HSK-E25, DIN 69893
Schlanke Schrumpffutter Slim Shrink Chucks

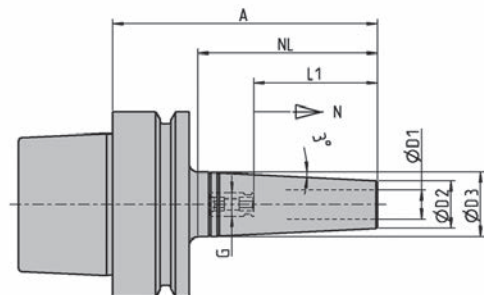

TSF... HSK - E25									G2,5/ 25.000	≤ 3µm	max. 50.000	coated
D1 [mm]	A [mm]	NL [mm]	D2 [mm]	D3 [mm]	L1 [mm]	N [mm]	G	Bezeichnung Designation	Ident No.			
3	45	33	9	12,5	23	8	M6	TSF0300-33/HSK-E25	5023510			
4	45	33	10	13,5	20	4	M6	TSF0400-33/HSK-E25	5023519			
5	45	33	11	14,5	20	3	M6	TSF0500-33/HSK-E25	5023524			
6	45	33	12	15,5	36	-	-	TSF0600-33/HSK-E25	5023525			
8	50	38	14	18	36	-	-	TSF0800-38/HSK-E25	5023528			
10	50	40	16	19	42	-	-	TSF1000-40/HSK-E25	5023530			
3	55	43	9	13,5	25	10	M5	TSF0300-43/HSK-E25	5023515			
4	55	43	10	14,5	20	13	M5	TSF0400-43/HSK-E25	5023521			
3	70	58	9	15	25	10	M6	TSF0300-58/HSK-E25	5023517			
4	70	58	10	16	20	15	M6	TSF0400-58/HSK-E25	5023523			
6	70	58	12	18	36	10	M5	TSF0600-58/HSK-E25	5023527			
8	70	59	14	18	36	7	M6	TSF0800-59/HSK-E25	5023529			
10	70	60	16	19	42	5	M8	TSF1000-60/HSK-E25	5023531			
		TSF Wechselscheiben siehe Zubehör Seite 92 TSF discs, see accessories page 92										
		5100005				5100007		Zubehör, siehe Seite 91 Accessories, page 91				

*Hinweis Wuchtgüte siehe Seite 14 Balancing Information, page 14

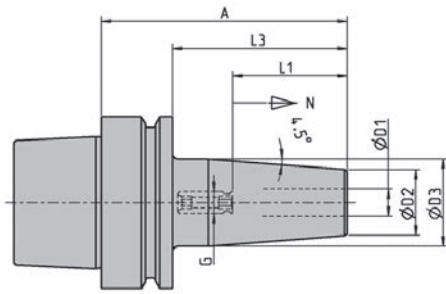

T... HSK - E32								G2,5 _k 25.000	≤ 3µm	max. 50.000	HSS
D1 [mm]	A [mm]	L3 [mm]	D2 [mm]	D3 [mm]	L1 [mm]	N [mm]	G	Bezeichnung Designation	Ident No.		
3	60	40	15	20	20	5	M6	T0300/HSK-E32	6726863		
4	60	40	15	20	20	5	M6	T0400/HSK-E32	6726574		
5	60	40	15	20	25	5	M6	T0500/HSK-E32	6726575		
6	70	50	20	26	36	10	M5	T0600/HSK-E32	6726289		
8	70	50	20	26	36	10	M6	T0800/HSK-E32	6726290		
10	70	50	24	29	42	10	M8x1	T1000/HSK-E32	6726291		
12	70	50	24	29	47	10	M10x1	T1200/HSK-E32	6726292		
		5064893				6738740		Zubehör, siehe Seite 91 Accessories, page 91			

Coming soon
 The new Bilz Shop.

Sie erreichen unseren neuen Shop bald unter
www.Bilz.de
 You will reach the new shop under
www.Bilz.com

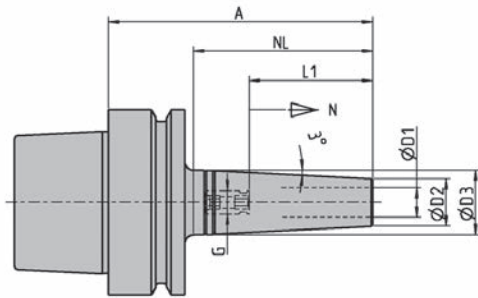

TSF... HSK-E32									G2,5/ 25.000	≤ 3µm	max. 50.000	coated	
D1 [mm]	A [mm]	NL [mm]	D2 [mm]	D3 [mm]	L1 [mm]	N [mm]	G	Bezeichnung Designation	Ident No.				
3	64	40	9	13	20	5	M6	TSF0300-40/HSK-E32	9078742				
4	64	40	10	14	20	5	M6	TSF0400-40/HSK-E32	9078744				
6	74	50	12	17	36	5	M5	TSF0600-50/HSK-E32	9078746				
8	74	50	14	19	36	5	M6	TSF0800-50/HSK-E32	9078748				
10	78	55	16	21	42	5	M8x1	TSF1000-55/HSK-E32	9078750				
3	94	70	9	16	20	5	M6	TSF0300-70/HSK-E32	9078743				
4	94	70	10	17	20	5	M6	TSF0400-70/HSK-E32	9078745				
6	104	80	12	20	36	5	M5	TSF0600-80/HSK-E32	9078747				
8	104	80	14	22	36	5	M6	TSF0800-80/HSK-E32	9078749				
10	104	80	16	22	42	5	M8x1	TSF1000-80/HSK-E32	9078751				
TSF Wechselscheiben siehe Zubehör Seite 92 TSF discs, see accessories page 92													
5064893		6738740		Zubehör, siehe Seite 91 Accessories, page 91									

TSF... HSK-E32 – Inch									G2,5/ 25.000	≤ 3µm	max. 50.000	coated	
D1 [Inch]	A [Inch]	NL [Inch]	D2 [Inch]	D3 [Inch]	L1 [Inch]	N [Inch]	G	Bezeichnung Designation	Ident No.				
0.125	2.52	1.57	0.39	0.55	0.79	0.20	M6	TSF0318-64/HSK-E32	5057306				
0.187	2.52	1.57	0.43	0.55	0.98	0.20	M6	TSF0476-64/HSK-E32	5057311				
0.250	2.91	1.97	0.47	0.67	1.42	0.20	M5	TSF0635-74/HSK-E32	5057313				
0.375	3.07	2.17	0.63	0.83	1.65	0.20	M8x1	TSF0953-78/HSK-E32	5057317				
0.125	3.70	2.76	0.39	0.67	0.79	0.20	M6	TSF0318-94/HSK-E32	5057309				
0.187	3.70	2.76	0.43	0.71	0.98	0.20	M6	TSF0476-94/HSK-E32	5057312				
0.250	4.09	3.15	0.47	0.79	1.42	0.20	M5	TSF0635-104/HSK-E32	5057315				
0.375	4.09	3.15	0.63	0.87	1.65	0.20	M8x1	TSF0953-104/HSK-E32	5057318				
TSF Wechselscheiben siehe Zubehör Seite 92 TSF discs, see accessories page 92													
5064893		6738740		Zubehör, siehe Seite 91 Accessories, page 91									

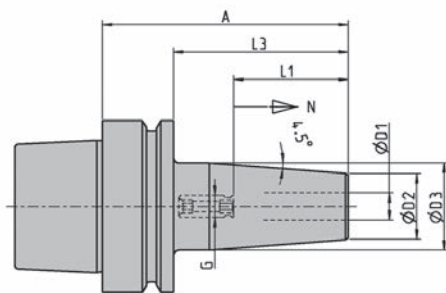

T... HSK - E40								G2.5/ 25.000	≤ 3µm	max. 42.000	coated	HSS
D1 [mm]	A [mm]	L3 [mm]	D2 [mm]	D3 [mm]	L1 [mm]	N [mm]	G	Bezeichnung Designation	Ident No.			
3	60	40	15	20	20	5	M6	T0300/HSK-E40	6726576			
4	60	40	15	20	20	5	M6	T0400/HSK-E40	6726577			
5	60	40	15	20	25	5	M6	T0500/HSK-E40	6726578			
6	65	45	21	27	36	-	-	T0600-65/HSK-E40	6726626			
8	65	45	21	27	36	-	-	T0800-65/HSK-E40	6726627			
10	65	45	24	30	42	-	-	T1000-65/HSK-E40	9081714			
12	65	45	24	30	47	-	-	T1200-65/HSK-E40	6727546			
3	80	60	15	20	20	5	M6	T0300-80/HSK-E40	5012455			
4	80	60	15	20	20	5	M6	T0400-80/HSK-E40	9145679			
5	80	60	15	20	25	5	M6	T0500-80/HSK-E40	5031332			
6	80	60	21	27	36	10	M5	T0600/HSK-E40	6726299			
8	80	60	21	27	36	10	M6	T0800/HSK-E40	6726300			
10	80	60	24	32	42	10	M8x1	T1000/HSK-E40	6726301			
12	90	70	24	32	47	10	M10x1	T1200/HSK-E40	6726302			
16	90	70	27	34	50	10	M12x1	T1600/HSK-E40	6726304			
3	120	100	15	20	20	5	M6	T0300-120/HSK-E40	6727478			
4	120	100	15	20	20	5	M6	T0400-120/HSK-E40	6727497			
5	120	100	15	20	25	5	M6	T0500-120/HSK-E40	6727498			
6	120	100	21	27	36	10	M5	T0600-120/HSK-E40	6726989			
8	120	100	21	27	36	10	M6	T0800-120/HSK-E40	6726990			
10	120	100	24	32	42	10	M8x1	T1000-120/HSK-E40	6726991			
12	120	100	24	32	47	10	M10x1	T1200-120/HSK-E40	6726992			
		5028425				6738741		Zubehör, siehe Seite 91 Accessories, page 91				

T... HSK-E40, DIN 69893
 Schrumpffutter Shrink Chucks

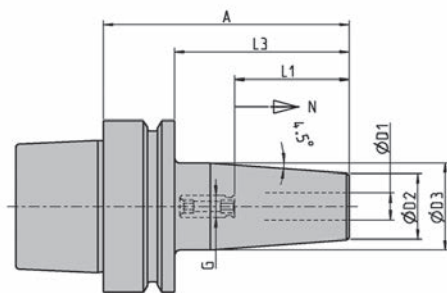

T... HSK - E40 – Inch									G2,5/ 25.000	≤ 3µm	max. 42.000	HSS
D1 [Inch]	A [Inch]	L3 [Inch]	D2 [Inch]	D3 [Inch]	L1 [Inch]	N [Inch]	G	Bezeichnung Designation	IdentNo.			
0.125	2.36	1,57	0.83	1.06	1.42	0.39	M6	T0318-60/HSK-E40	9079262			
0.187	2.36	1,57	0.83	1.06	1.42	0.39	M6	T0476-60/HSK-E40	9079269			
0.250	3.15	2,36	0.83	1.06	1.42	0.39	M5	T0635-80/HSK-E40	9079208			
0.375	3.15	2,36	0.95	1.26	1.65	0.39	M8x1	T0953-80/HSK-E40	9079215			
0.500	3.54	2,76	1.06	1.34	1.85	0.39	M10x1	T1270-90/HSK-E40	9079243			
0.625	3.54	2,76	1.06	1.34	1.97	0.39	M12x1	T1588-90/HSK-E40	9079248			
0.125	4.72	3,94	0.83	1.06	1.42	0.39	M6	T0318-120/HSK-E40	9079263			
0.187	4.72	3,94	0.83	1.06	1.42	0.39	M6	T0476-120/HSK-E40	9079270			
0.250	4.72	3,94	0.83	1.06	1.42	0.39	M5	T0635-120/HSK-E40	9079210			
0.375	4.72	3,94	0.95	1.26	1.65	0.39	M8x1	T0953-120/HSK-E40	9079216			
0.500	4.72	3,94	1.06	1.34	1.85	0.39	M10x1	T1270-120/HSK-E40	9079244			
0.625	4.72	3,94	1.06	1.34	1.97	0.39	M12x1	T1588-120/HSK-E40	9079249			
		5028425				6738741		Zubehör, siehe Seite 91 Accessories, page 91				

*Hinweis Wuchtgüte siehe Seite 14 Balancing Information, page 14

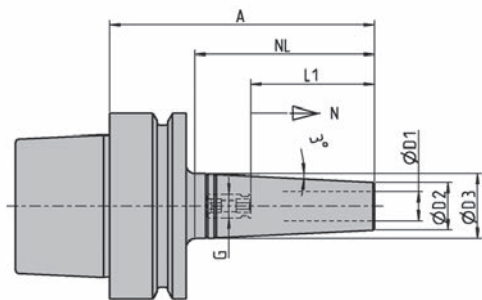

TSF... HSK-E40



D1 [mm]	A [mm]	NL [mm]	D2 [mm]	D3 [mm]	L1 [mm]	N [mm]	G	Bezeichnung Designation	Ident No.
3	50	24	9	12	20	5	M6	TSF0300-24/HSK-E40	5035774
4	50	24	10	12,5	20	5	M6	TSF0400-24/HSK-E40	5035773
6	50	24	12	15	34	-	-	TSF0600-24/HSK-E40	5035770
6	60	38	12	16	36	-	-	TSF0600-38/HSK-E40	9078910
8	60	38	14	18	36	-	-	TSF0800-38/HSK-E40	9078925
10	60	38	16	20	42	-	-	TSF1000-38/HSK-E40	9078926
12	60	38	18	22	42	-	-	TSF1200-38/HSK-E40	9078927
3	64	40	9	13	20	5	M6	TSF0300-40/HSK-E40	9078566
4	64	40	10	14	20	5	M6	TSF0400-40/HSK-E40	9078570
5	64	40	11	15	20	5	M6	TSF0500-40/HSK-E40	9122963
6	84	60	12	18	36	5	M5	TSF0600-60/HSK-E40	9078572
8	84	60	14	20	36	5	M6	TSF0800-60/HSK-E40	9078576
10	84	60	16	22	42	5	M8x1	TSF1000-60/HSK-E40	9078579
12	84	60	18	24	47	5	M10x1	TSF1200-60/HSK-E40	9078582
3	94	70	9	16	20	5	M6	TSF0300-70/HSK-E40	9078569
4	94	70	10	17	20	5	M6	TSF0400-70/HSK-E40	9078571
5	94	70	11	18	20	5	M6	TSF0500-70/HSK-E40	9142898
6	114	90	12	21	36	5	M5	TSF0600-90/HSK-E40	9078573
8	114	90	14	23	36	5	M6	TSF0800-90/HSK-E40	9078577
10	114	90	16	25	42	5	M8x1	TSF1000-90/HSK-E40	9078580
12	114	90	18	27	47	5	M10x1	TSF1200-90/HSK-E40	9078583
6	144	120	12	24	36	5	M5	TSF0600-120/HSK-E40	9078574
8	144	120	14	26	36	5	M6	TSF0800-120/HSK-E40	9078578
10	144	120	16	28	42	5	M8x1	TSF1000-120/HSK-E40	9078581
12	144	120	18	30	47	5	M10x1	TSF1200-120/HSK-E40	9078584



TSF Wechselscheiben siehe Zubehör Seite 92 TSF discs, see accessories page 92



5028425



6738741

Zubehör, siehe Seite 91 Accessories, page 91

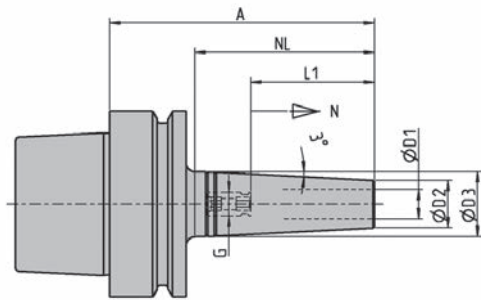

TSF... HSK-E40 – Inch									G2,5/ 25.000	≤ 3µm	max. 42.000	coated	
D1 [Inch]	A [Inch]	NL [Inch]	D2 [Inch]	D3 [Inch]	L1 [Inch]	N [Inch]	G	Bezeichnung Designation	Ident No.				
0.125	2.52	1.65	0.39	0.55	0.79	0.20	M6	TSF0318-64/HSK-E40	5054359				
0.187	2.52	1.57	0.39	0.55	0.98	0.20	M6	TSF0476-64/HSK-E40	5054361				
0.250	2.56	1.50	0.47	0.63	1.42	-	-	TSF0635-65/HSK-E40	-				
0.375	2.56	1.50	0.63	0.79	1.65	-	-	TSF0953-65/HSK-E40	-				
0.500	2.56	1.50	0.71	0.87	1.65	-	-	TSF1270-65/HSK-E40	-				
0.125	3.70	2.76	0.39	0.67	0.79	0.20	M6	TSF0318-94/HSK-E40	5054360				
0.187	3.70	2.76	0.43	0.71	0.98	0.20	M6	TSF0476-94/HSK-E40	5054362				
0.250	3.31	2.36	0.47	0.71	1.42	0.20	M5	TSF0635-90/HSK-E40	5054363				
0.375	3.31	2.36	0.63	0.87	1.65	0.20	M8x1	TSF0953-84/HSK-E40	5054367				
0.500	3.54	2.36	0.71	0.94	1.85	0.20	M10x1	TSF1270-90/HSK-E40	-				
0.125	4.72	2.76	0.35	0.63	0.79	0.20	M6	TSF0318-120/HSK-E40	-				
0.187	4.72	2.76	0.39	0.67	0.79	0.20	M6	TSF0476-120/HSK-E40	-				
0.250	4.49	3.54	0.47	0.83	1.42	0.20	M5	TSF0635-114/HSK-E40	5054364				
0.375	4.49	3.54	0.63	0.98	1.65	0.20	M8x1	TSF0953-114/HSK-E40	5054368				
0.500	4.72	3.54	0.71	1.06	1.85	0.20	M10x1	TSF1270-120/HSK-E40	-				
0.250	5.67	4.72	0.47	0.94	1.42	0.20	M5	TSF0635-144/HSK-E40	5054365				
0.375	5.67	4.72	0.63	1.10	1.65	0.20	M8x1	TSF0965-144/HSK-E40	5054369				
0.500	6.30	4.72	0.71	1.18	1.85	0.20	M12x1	TSF1270-160/HSK-E40	-				
	TSF Wechselscheiben siehe Zubehör Seite 92 TSF discs, see accessories page 92												
	5028425		6738741	Zubehör, siehe Seite 91 Accessories, page 91									

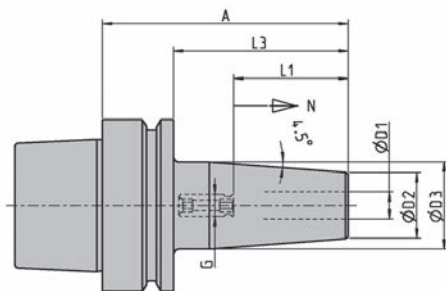

T... HSK - E50								G2,5/ 25.000	≤ 3µm	max. 36.000	HSS
D1 [mm]	A [mm]	L3 [mm]	D2 [mm]	D3 [mm]	L1 [mm]	N [mm]	G	Bezeichnung Designation	Ident No.		
3	80	54	15	20	20	5	M6	T0300/HSK-E50	6726654		
4	80	54	15	20	20	5	M6	T0400/HSK-E50	6726655		
5	80	54	15	20	20	5	M6	T0500/HSK-E50	6726656		
6	80	54	21	27	36	10	M5	T0600/HSK-E50	6726309		
8	80	54	21	27	36	10	M6	T0800/HSK-E50	6726310		
10	85	59	24	32	42	10	M8x1	T1000/HSK-E50	6726311		
12	90	64	24	32	47	10	M10x1	T1200/HSK-E50	6726312		
14	90	64	27	34	47	10	M10x1	T1400/HSK-E50	6726313		
16	95	69	27	34	50	10	M12x1	T1600/HSK-E50	6726314		
18	95	69	33	42	50	10	M12x1	T1800/HSK-E50	6726315		
20	100	74	33	42	52	10	M16x1	T2000/HSK-E50	6726316		
3	120	94	15	20	20	5	M6	T0300-120/HSK-E50	6773345		
4	120	94	15	20	20	5	M6	T0400-120/HSK-E50	6727172		
5	120	94	15	20	20	5	M6	T0500-120/HSK-E50	9080804		
6	120	94	21	27	36	10	M5	T0600-120/HSK-E50	6726888		
8	120	94	21	27	36	10	M6	T0800-120/HSK-E50	6726891		
10	120	94	24	32	42	10	M8x1	T1000-120/HSK-E50	6726756		
12	120	94	24	32	47	10	M10x1	T1200-120/HSK-E50	6726896		
16	120	94	27	34	50	10	M12x1	T1600-120/HSK-E50	6726964		
		5028426				6738442		Zubehör, siehe Seite 91 Accessories, page 91			

T... HSK-E50, DIN 69893
Schrumpffutter Shrink Chucks

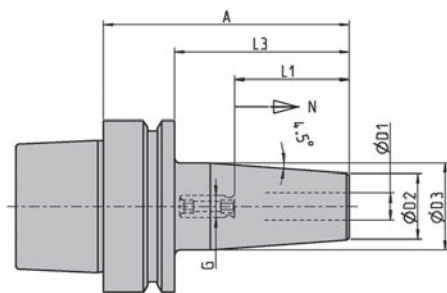

T... HSK - E50 – Inch									G2,5/ 25.000	≤ 3µm	max. 36.000	HSS
D1 [Inch]	A [Inch]	L3 [Inch]	D2 [Inch]	D3 [Inch]	L1 [Inch]	N [Inch]	G	Bezeichnung Designation	Ident No.			
0.125	3.15	2,13	0.83	1.06	1.42	0.39	M6	T0318-80/HSK-E50	9079264			
0.187	3.15	2,13	0.83	1.06	1.42	0.39	M6	T0476-80/HSK-E50	9079271			
0.250	3.15	2,13	0.83	1.06	1.42	0.39	M5	T0635-80/HSK-E50	6727386			
0.375	3.35	2,32	0.95	1.26	1.65	0.39	M8x1	T0953-85/HSK-E50	6727388			
0.500	3.54	2,52	1.06	1.34	1.85	0.39	M10x1	T1270-90/HSK-E50	6727390			
0.625	3.74	2,72	1.06	1.34	1.97	0.39	M12x1	T1588-95/HSK-E50	9079250			
0.750	3.94	2,91	1.30	1.65	2.05	0.39	M16x1	T1905-100/HSK-E50	9079256			
0.125	6.30	5,28	0.83	1.26	1.42	0.39	M6	T0318-160/HSK-E50	9079265			
0.187	6.30	5,28	0.83	1.26	1.42	0.39	M6	T0476-160/HSK-E50	9079272			
0.250	6.30	5,28	0.83	1.26	1.42	0.39	M5	T0635-160/HSK-E50	9079211			
0.375	6.30	5,28	0.95	1.34	1.65	0.39	M8x1	T0953-160/HSK-E50	9079218			
0.500	6.30	5,28	1.06	1.65	1.85	0.39	M10x1	T1270-160/HSK-E50	9079245			
0.625	6.30	5,28	1.06	1.65	1.97	0.39	M12x1	T1588-160/HSK-E50	9079252			
0.750	6.30	5,28	1.30	2.01	2.05	0.39	M16x1	T1905-160/HSK-E50	9079257			
		5028426				6738442		Zubehör, siehe Seite 91 Accessories, page 91				

*Hinweis Wuchtgüte siehe Seite 14 Balancing Information, page 14

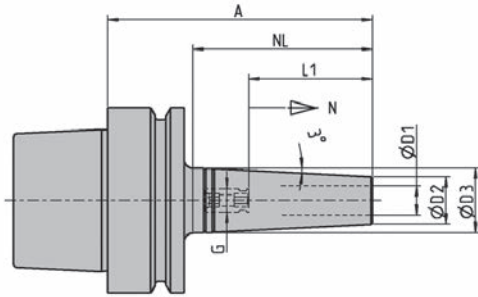

TSF... HSK-E50									G2,5/ 25.000	≤ 3µm	max. 36.000	coated	
D1 [mm]	A [mm]	NL [mm]	D2 [mm]	D3 [mm]	L1 [mm]	N [mm]	G	Bezeichnung Designation	Ident No.				
3	70	42	9	13	20	5	M6	TSF0300-42/HSK-E50	9078885				
4	70	42	10	14	20	5	M6	TSF0400-42/HSK-E50	9078888				
6	70	42	12	16	36	5	M5	TSF0600-42/HSK-E50	9078929				
8	70	42	14	18	36	5	M6	TSF0800-42/HSK-E50	9078931				
10	70	42	16	20	42	-	-	TSF1000-42/HSK-E50	9078932				
12	70	42	18	22	47	-	-	TSF1200-42/HSK-E50	9078933				
16	70	41	22	26	47	-	-	TSF1600-41/HSK-E50	5038979				
6	90	60	12	18	36	5	M5	TSF0600-60/HSK-E50	9078892				
8	90	60	14	20	36	5	M6	TSF0800-60/HSK-E50	9078895				
10	90	60	16	22	42	5	M8x1	TSF1000-60/HSK-E50	9078898				
12	90	60	18	24	47	5	M10x1	TSF1200-60/HSK-E50	9078901				
16	90	60	22	28	50	5	M16x1	TSF1600-60/HSK-E50	9078906				
3	100	70	9	16	20	5	M6	TSF0300-70/HSK-E50	9078887				
4	100	70	10	17	20	5	M6	TSF0400-70/HSK-E50	9078889				
6	120	90	12	21	36	5	M5	TSF0600-90/HSK-E50	9078893				
8	120	90	14	23	36	5	M6	TSF0800-90/HSK-E50	9078896				
10	120	90	16	25	42	5	M8x1	TSF1000-90/HSK-E50	9078899				
12	120	90	18	27	47	5	M10x1	TSF1200-90/HSK-E50	9078902				
16	120	90	22	31	50	5	M16x1	TSF1600-90/HSK-E50	9078908				
6	150	120	12	24	36	5	M5	TSF0600-120/HSK-E50	9078894				
8	150	120	14	26	36	5	M6	TSF0800-120/HSK-E50	9078897				
10	150	120	16	28	42	5	M8x1	TSF1000-120/HSK-E50	9078900				
12	150	120	18	30	47	5	M10x1	TSF1200-120/HSK-E50	9078903				
16	150	120	22	34	50	5	M16x1	TSF1600-120/HSK-E50	9078909				
TSF Wechselscheiben siehe Zubehör Seite 92 TSF discs, see accessories page 92													
5028426		6738442		Zubehör, siehe Seite 91 Accessories, page 91									

TSF... HSK-E50, DIN 69893
Schlanke Schrumpffutter Slim Shrink Chucks

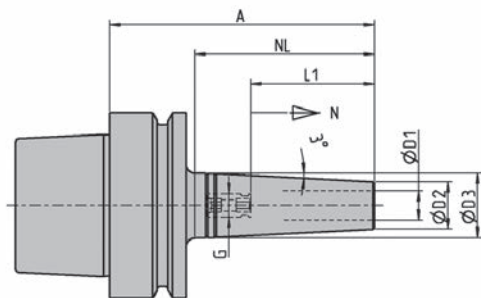

TSF... HSK-E50 – Inch									G2.5/ 25.000	≤ 3µm	max. 36.000	coated	
D1 [Inch]	A [Inch]	NL [Inch]	D2 [Inch]	D3 [Inch]	L1 [Inch]	N [Inch]	G	Bezeichnung Designation	Ident No.				
0.125	2.76	1.65	0.39	0.55	0.79	0.20	M6	TSF0318-70/HSK-E50	5054183				
0.187	2.76	1.65	0.39	0.55	0.98	0.20	M6	TSF0476-70/HSK-E50	5054185				
0.250	2.76	1.65	0.47	0.63	1.42	0.20	M5	TSF0635-70/HSK-E50	5054196				
0.375	2.76	1.65	0.63	0.79	1.65	0.20	–	TSF0953-70/HSK-E50	5054200				
0.500	2.76	1.65	0.71	0.87	1.85	–	–	TSF1270-70/HSK-E50	–				
0.625	2.76	1.65	0.87	1.02	1.85	–	–	TSF1588-70/HSK-E50	–				
0.250	3.54	2.36	0.47	0.71	1.42	0.20	M5	TSF0635-90/HSK-E50	5054197				
0.375	3.54	2.36	0.63	0.87	1.65	0.20	M8x1	TSF0953-90/HSK-E50	5054201				
0.500	3.54	2.36	0.79	1.02	1.85	0.20	M10x1	TSF1270-90/HSK-E50	5054205				
0.625	3.54	2.36	0.87	1.10	1.97	0.20	M10x1	TSF1588-90/HSK-E50	5054208				
0.125	3.94	2.76	0.39	0.67	0.79	0.20	M6	TSF0318-100/HSK-E50	5054184				
0.187	3.94	2.76	0.43	0.71	0.98	0.20	M6	TSF0476-100/HSK-E50	5054186				
0.250	4.72	3.54	0.47	0.83	1.42	0.20	M5	TSF0635-120/HSK-E50	5054198				
0.375	4.72	3.54	0.63	0.98	1.65	0.20	M8x1	TSF0953-120/HSK-E50	5054202				
0.500	4.72	3.54	0.79	1.14	1.85	0.20	M10x1	TSF1270-120/HSK-E50	5054206				
0.625	4.72	3.54	0.87	1.22	1.97	0.20	M10x1	TSF1588-120/HSK-E50	5054209				
0.250	5.91	4.88	0.47	0.94	1.42	0.20	M5	TSF0635-150/HSK-E50	5054199				
0.375	5.91	4.72	0.63	1.10	1.65	0.20	M8x1	TSF0953-150/HSK-E50	5054203				
0.500	5.91	4.72	0.79	1.26	1.85	0.20	M10x1	TSF1270-150/HSK-E50	5054207				
0.625	5.91	4.72	0.87	1.34	1.97	0.20	M10x1	TSF1588-150/HSK-E50	5054210				
TSF Wechselscheiben siehe Zubehör Seite 92 TSF discs, see accessories page 92													
5028426			6738442			Zubehör, siehe Seite 91 Accessories, page 91							

*Hinweis Wuchtgüte siehe Seite 14 Balancing Information, page 14

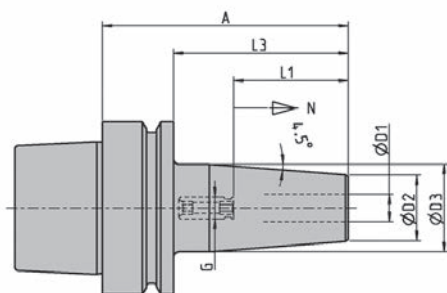

T... HSK - E63									G2,5 _h 25.000	≤ 3µm	max. 30.000	HSS
D1 [mm]	A [mm]	L3 [mm]	D2 [mm]	D3 [mm]	L1 [mm]	N [mm]	G	Bezeichnung Designation	Ident No.			
6	80	54	21	27	36	10	M5	T0600/HSK-E63	6726319			
8	80	54	21	27	36	10	M6	T0800/HSK-E63	6726320			
10	85	59	24	32	42	10	M8 x 1	T1000/HSK-E63	6726321			
12	90	64	24	32	47	10	M10 x 1	T1200/HSK-E63	6726322			
14	90	64	27	34	47	10	M10 x 1	T1400/HSK-E63	6726323			
16	95	69	27	34	50	10	M12 x 1	T1600/HSK-E63	6726324			
18	95	69	33	42	50	10	M12 x 1	T1800/HSK-E63	6726325			
20	100	74	33	42	52	10	M16 x 1	T2000/HSK-E63	6726326			
25	115	89	44	53	58	10	M16 x 1	T2500/HSK-E63	6726327			
		5025376				6738421		Zubehör, siehe Seite 91 Accessories, page 91				

T... HSK-F40, DIN 69893
Schrumpffutter Shrink Chucks

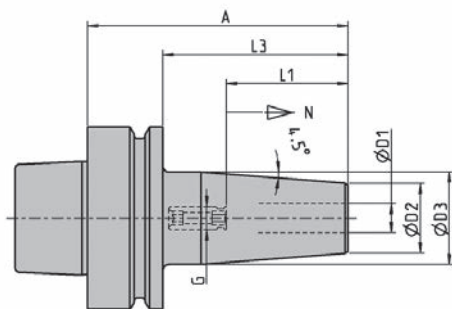

T... HSK - F40									G2,5/ 25.000	≤ 3µm	max. 50.000	HSS
D1 [mm]	A [mm]	L3 [mm]	D2 [mm]	D3 [mm]	L1 [mm]	N [mm]	G	Bezeichnung Designation	Ident No.			
3	60	40	15	20	20	5	M6	T0300-60/HSK-F40	5036785			
4	60	40	15	20	20	5	M6	T0400-60/HSK-F40	5036786			
5	60	40	15	20	20	5	M6	T0500-60/HSK-F40	5036788			
6	65	45	21	27	36	5	M5	T0600-65/HSK-F40	5026620			
8	65	45	21	27	36	5	M6	T0800-65/HSK-F40	5036791			
10	65	45	24	31	42	5	M8x1	T1000-65/HSK-F40	5036792			
12	65	45	24	31	42	5	M10x1	T1200-65/HSK-F40	5036793			
6	80	60	21	27	36	10	M5	T0600-80/HSK-F40	5036794			
8	80	60	21	27	36	10	M6	T0800-80/HSK-F40	5036795			
10	80	60	24	32	42	10	M8x1	T1000-80/HSK-F40	5036797			
12	90	70	24	32	47	10	M10x1	T1200-90/HSK-F40	5036798			
16	90	70	27	34	50	10	M12x1	T1600-90/HSK-F40	5036799			

TSF... HSK-F40, DIN 69893
Schlanke Schrumpffutter Slim Shrink Chucks

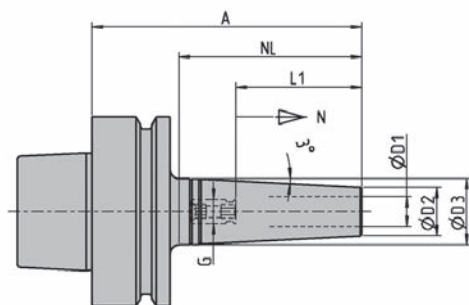

TSF... HSK - F40									G2,5/ 25.000	≤ 3µm	max. 50.000	coated
D1 [mm]	A [mm]	NL [mm]	D2 [mm]	D3 [mm]	L1 [mm]	N [mm]	G	Bezeichnung Designation	Ident No.			
6	70	48	12	17	36	10	M5	TSF0600-48/HSK-F40	5083004			
8	70	48	14	19	36	10	M6	TSF0800-48/HSK-F40	5083009			
10	80	58	16	22	42	10	M8x1	TSF1000-58/HSK-F40	-			
12	80	58	18	24	42	10	M10x1	TSF1200-58/HSK-F40	-			

TSF Wechselscheiben siehe Zubehör Seite 92 TSF discs, see accessories page 92

*Hinweis Wuchtgüte siehe Seite 14 Balancing Information, page 14

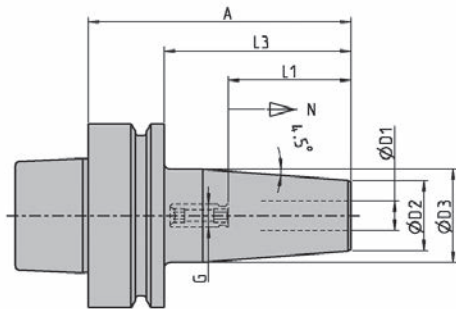

T... HSK - F63									G2,5/ 25.000	≤ 3µm	max. 36.000	HSS
D1 [mm]	A [mm]	L3 [mm]	D2 [mm]	D3 [mm]	L1 [mm]	N [mm]	G	Bezeichnung Designation	Ident No.			
3	90	54	15	20	20	5	M6	T0300/HSK-F63	9107682			
4	90	54	15	20	20	5	M6	T0400/HSK-F63	6773733			
5	90	54	15	20	25	5	M6	T0500/HSK-F63	9091580			
6	90	64	21	27	36	10	M5	T0600-90/HSK-F63	9122311			
8	90	64	21	27	36	10	M6	T0800-90/HSK-F63	9122312			
10	90	64	24	32	42	10	M8x1	T1000/HSK-F63	6726373			
12	90	64	24	32	47	10	M10x1	T1200/HSK-F63	6726374			
14	95	69	27	34	47	10	M10x1	T1400/HSK-F63	6726393			
16	95	69	27	34	50	10	M12x1	T1600/HSK-F63	6726414			
18	95	69	33	42	50	10	M12x1	T1800/HSK-F63	6726415			
20	100	74	33	42	52	10	M16x1	T2000/HSK-F63	6726375			
25	115	89	36	42	58	10	M16x1	T2500/HSK-F63	6727436			
3	120	94	15	20	20	5	M6	T0300-120/HSK-F63	9115118			
4	120	94	15	20	20	5	M6	T0400-120/HSK-F63	9115149			
5	120	94	15	20	25	5	M6	T0500-120/HSK-F63	9115150			
6	120	94	21	27	36	10	M5	T0600-120/HSK-F63	9075284			
8	120	94	21	27	36	10	M6	T0800-120/HSK-F63	6726841			
10	120	94	24	32	42	10	M8x1	T1000-120/HSK-F63	6727435			
12	120	94	24	32	47	10	M10x1	T1200-120/HSK-F63	6726810			
14	120	94	27	34	47	10	M10x1	T1400-120/HSK-F63	9115151			
16	120	94	27	34	50	10	M12x1	T1600-120/HSK-F63	9077033			
18	120	94	33	42	50	10	M12x1	T1800-120/HSK-F63	9115152			
20	120	94	33	42	52	10	M16x1	T2000-120/HSK-F63	9115153			
3	160	134	15	27	20	5	M6	T0300-160/HSK-F63	9115154			
4	160	134	15	27	20	5	M6	T0400-160/HSK-F63	9115155			
5	160	134	15	27	25	5	M6	T0500-160/HSK-F63	9115156			
6	160	134	21	32	36	10	M5	T0600-160/HSK-F63	9115158			
8	160	134	21	32	36	10	M6	T0800-160/HSK-F63	9080135			
10	160	134	24	34	42	10	M8x1	T1000-160/HSK-F63	9080136			
12	160	134	24	34	47	10	M10x1	T1200-160/HSK-F63	6727465			
14	160	134	27	42	47	10	M10x1	T1400-160/HSK-F63	9115160			
16	160	134	27	42	50	10	M12x1	T1600-160/HSK-F63	9097804			
18	160	134	33	51	50	10	M12x1	T1800-160/HSK-F63	9115162			
20	160	134	33	51	52	10	M16x1	T2000-160/HSK-F63	9075282			

T... HSK-F63, DIN 69893
Schrumpffutter Shrink Chucks

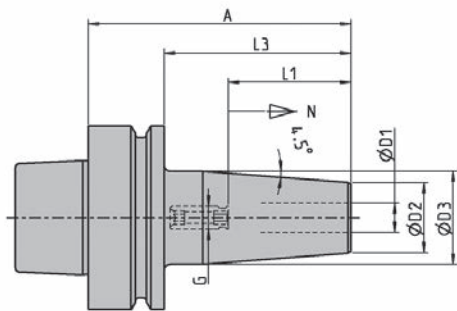

T... HSK - F63 – Inch									G2,5/ 25.000	≤ 3µm	max. 36.000	HSS
D1 [Inch]	A [Inch]	L3 [Inch]	D2 [Inch]	D3 [Inch]	L1 [Inch]	N [Inch]	G	Bezeichnung Designation	Ident No.			
0,250	3,54	2,52	0,83	1,06	1,42	0,39	M5	T0635-90/HSK-F63	5057126			
0,312	3,54	2,52	0,83	1,06	1,42	0,39	M6	T0794-90/HSK-F63	5061847			
0,375	3,54	2,52	0,94	1,26	1,65	0,39	M8X1	T0953-90/HSK-F63	5057131			
0,500	3,54	2,52	1,06	1,34	1,85	0,39	M10X1	T1270-95/HSK-F63	5057133			
0,625	3,74	2,72	1,06	1,34	1,97	0,39	M12X1	T1588-95/HSK-F63	5057140			
0,750	3,94	2,91	1,30	1,65	2,05	0,39	M16X1	T1905-100/HSK-F63	5057142			
1,000	4,53	3,50	1,73	2,09	2,44	0,39	M16X1	T2540-115/HSK-F63	5057148			

*Hinweis Wuchtgüte siehe Seite 14 Balancing Information, page 14

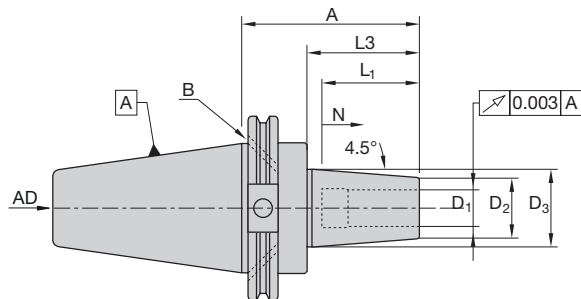

T... CAT 40 – Inch								G2,5/25.000	≤ 3µm	max. 18.000	HSS
D1 [Inch]	A [Inch]	L3 [Inch]	D2 [Inch]	D3 [Inch]	L1 [Inch]	N [Inch]	G	Bezeichnung Designation	Ident No.		
0,125	3,74	2,36	0,59	0,79	0,79	0,20	M6	T0318-95/CAT40ADB-UNC	9087264		
0,187	3,74	2,36	0,59	0,79	0,98	0,20	M6	T0476-95/CAT40ADB-UNC	9087265		
0,250	3,74	2,36	0,83	1,06	1,42	0,39	M5	T0635/CAT40ADB-UNC	9075136		
0,312	3,74	2,36	0,83	1,06	1,42	0,39	M6	T0794-95/CAT40ADB-UNC	9087266		
0,375	3,74	2,36	0,94	1,26	1,65	0,39	M8X1	T0953/CAT40ADB-UNC	9074678		
0,500	3,74	2,36	1,06	1,34	1,85	0,39	M10X1	T1270/CAT40ADB-UNC	9074679		
0,625	3,74	2,36	1,06	1,34	1,97	0,39	M12X1	T1588/CAT40ADB-UNC	9074680		
0,750	3,74	2,36	1,30	1,65	2,05	0,39	M16X1	T1905/CAT40ADB-UNC	9074681		
1,000	3,94	2,56	1,73	2,09	2,44	0,39	M16X1	T2540-100/CAT40ADB-UNC	9074675		
1,250	3,94	2,56	1,73	2,09	2,44	0,39	M16X1	T3175-100/CAT40ADB-UNC	9074647		
0,125	4,72	3,34	0,59	0,79	0,79	0,20	M6	T0318-120/CAT40ADB-UNC	9087267		
0,187	4,72	3,34	0,59	0,79	0,98	0,20	M6	T0476-120/CAT40ADB-UNC	9087268		
0,250	4,72	3,34	0,83	1,06	1,42	0,39	M5	T0635-120/CAT40ADB-UNC	9074633		
0,312	4,72	3,34	0,83	1,06	1,42	0,39	M6	T0794-120/CAT40ADB-UNC	9087269		
0,375	4,72	3,34	0,94	1,26	1,65	0,39	M8X1	T0953-120/CAT40ADB-UNC	9074635		
0,500	4,72	3,34	1,06	1,34	1,85	0,39	M10X1	T1270-120/CAT40ADB-UNC	9074637		
0,625	4,72	3,34	1,06	1,34	1,97	0,39	M12X1	T1588-120/CAT40ADB-UNC	9074639		
0,750	4,72	3,34	1,30	1,65	2,05	0,39	M16X1	T1905-120/CAT40ADB-UNC	9074641		
1,000	4,72	3,34	1,73	2,09	2,44	0,39	M16X1	T2540-120/CAT40ADB-UNC	9074645		
1,250	4,72	3,34	1,73	2,09	2,44	0,39	M16X1	T3175-120/CAT40ADB-UNC	9074648		
0,125	6,30	4,92	0,59	0,79	0,79	0,20	M6	T0318-160/CAT40ADB-UNC	9087270		
0,187	6,30	4,92	0,59	0,79	0,98	0,20	M6	T0476-160/CAT40ADB-UNC	9087271		
0,250	6,30	4,92	0,83	1,26	1,42	0,39	M5	T0635-160/CAT40ADB-UNC	9074634		
0,312	6,30	4,92	0,83	1,26	1,42	0,39	M6	T0794-160/CAT40ADB-UNC	9087272		
0,375	6,30	4,92	0,94	1,34	1,65	0,39	M8X1	T0953-160/CAT40ADB-UNC	9074636		
0,500	6,30	4,92	1,06	1,65	1,85	0,39	M10X1	T1270-160/CAT40ADB-UNC	9074638		
0,625	6,30	4,92	1,06	1,65	1,97	0,39	M12X1	T1588-160/CAT40ADB-UNC	9074640		
0,750	6,30	4,92	1,30	1,75	2,05	0,39	M16X1	T1905-160/CAT40ADB-UNC	9074642		
1,000	6,30	4,92	1,73	2,09	2,44	0,39	M16X1	T2540-160/CAT40ADB-UNC	9074646		
1,250	6,30	4,92	1,73	2,09	2,44	0,39	M16X1	T3175-160/CAT40ADB-UNC	9074649		

T... CAT 40, ANSI B5.50
Schrumpffutter Shrink Chucks

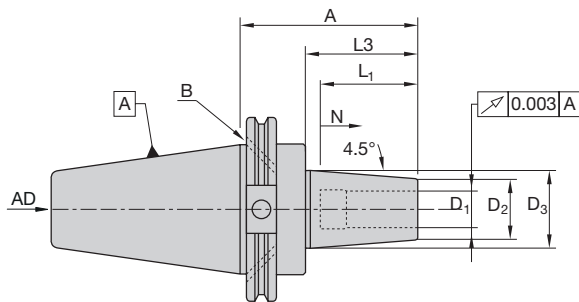

T... CAT 40								G2,5/ 25.000	≤ 3µm	max. 18.000	HSS
D1 [mm]	A [mm]	L3 [mm]	D2 [mm]	D3 [mm]	L1 [mm]	N [mm]	G	Bezeichnung Designation	Ident No.		
3	95	60	15	20	20	5	M6	T0300-95/CAT40ADB-UNC	9087273		
4	95	60	15	20	20	5	M6	T0400-95/CAT40ADB-UNC	9087286		
5	95	60	15	20	25	5	M6	T0500-95/CAT40ADB-UNC	9087287		
6	95	60	21	27	36	10	M5	T0600-95/CAT40ADB-UNC	9074627		
8	95	60	21	27	36	10	M6	T0800-95/CAT40ADB-UNC	9074628		
10	95	60	24	32	42	10	M8x1	T1000-95/CAT40ADB-UNC	9074629		
12	95	60	24	32	47	10	M10x1	T1200-95/CAT40ADB-UNC	9074630		
14	95	60	27	34	47	10	M10x1	T1400-95/CAT40ADB-UNC	9074658		
16	95	60	27	34	50	10	M12x1	T1600-95/CAT40ADB-UNC	9074631		
18	95	60	33	42	50	10	M12x1	T1800-95/CAT40ADB-UNC	9074664		
20	95	60	33	42	52	10	M16x1	T2000-95/CAT40ADB-UNC	9074632		
25	100	65	44	53	58	10	M16x1	T2500-100/CAT40ADB-UNC	9074760		
32	100	65	44	53	62	10	M16x1	T3200-100/CAT40ADB-UNC	9074672		
6	120	85	21	27	36	10	M5	T0600-120/CAT40ADB-UNC	9074650		
8	120	85	21	27	36	10	M6	T0800-120/CAT40ADB-UNC	9074652		
10	120	85	24	32	42	10	M8x1	T1000-120/CAT40ADB-UNC	9074654		
12	120	85	24	32	47	10	M10x1	T1200-120/CAT40ADB-UNC	9074656		
14	120	85	27	34	47	10	M10x1	T1400-120/CAT40ADB-UNC	9074659		
16	120	85	27	34	50	10	M12x1	T1600-120/CAT40ADB-UNC	9074662		
18	120	85	33	42	50	10	M12x1	T1800-120/CAT40ADB-UNC	9074665		
20	120	85	33	42	52	10	M16x1	T2000-120/CAT40ADB-UNC	9074667		
25	120	85	44	53	58	10	M16x1	T2500-120/CAT40ADB-UNC	9074669		
32	120	85	44	53	62	10	M16x1	T3200-120/CAT40ADB-UNC	9074673		
6	160	125	21	32	36	10	M5	T0600-160/CAT40ADB-UNC	9074651		
8	160	125	21	32	36	10	M6	T0800-160/CAT40ADB-UNC	9074653		
10	160	125	24	34	42	10	M8x1	T1000-160/CAT40ADB-UNC	9074655		
12	160	125	24	34	47	10	M10x1	T1200-160/CAT40ADB-UNC	9074657		
14	160	125	27	42	47	10	M10x1	T1400-160/CAT40ADB-UNC	9074661		
16	160	125	27	42	50	10	M12x1	T1600-160/CAT40ADB-UNC	9074663		
18	160	125	33	44	50	10	M12x1	T1800-160/CAT40ADB-UNC	9074666		
20	160	125	44	53	52	10	M16x1	T2000-160/CAT40ADB-UNC	9074668		
25	160	125	44	53	58	10	M16x1	T2500-160/CAT40ADB-UNC	9074671		
32	160	125	44	53	62	10	M16x1	T3200-160/CAT40ADB-UNC	9074674		

*Hinweis Wuchtgüte siehe Seite 14 Balancing Information, page 14

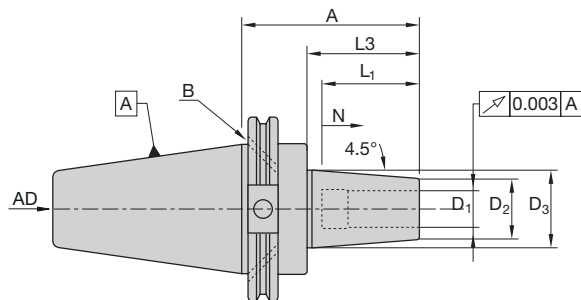

T... CAT 50 – Inch								G2,5/ 25.000	≤ 3µm	max. 12.000	HSS
D1 [Inch]	A [Inch]	L3 [Inch]	D2 [Inch]	D3 [Inch]	L1 [Inch]	N [Inch]	G	Bezeichnung Designation	Ident No.		
0,250	3,74	2,36	0,83	1,06	1,42	0,39	M5	T0635/CAT50ADB-UNC	9074085		
0,375	3,74	2,36	0,94	1,26	1,65	0,39	M8X1	T0953/CAT50ADB-UNC	9074102		
0,500	3,74	2,36	1,06	1,34	1,85	0,39	M10X1	T1270/CAT50ADB-UNC	9074105		
0,625	3,74	2,36	1,06	1,34	1,97	0,39	M12X1	T1588/CAT50ADB-UNC	9074108		
0,750	3,74	2,36	1,30	1,65	2,05	0,39	M16X1	T1905/CAT50ADB-UNC	9074111		
1,000	4,13	2,75	1,73	2,09	2,44	0,39	M16X1	T2540/CAT50ADB-UNC	9074115		
1,250	4,13	2,75	1,73	2,09	2,44	0,39	M16X1	T3175/CAT50ADB-UNC	9074118		
0,250	4,72	3,35	0,83	1,06	1,42	0,39	M5	T0635-120/CAT50ADB-UNC	9074098		
0,375	4,72	3,35	0,94	1,26	1,65	0,39	M8X1	T0953-120/CAT50ADB-UNC	9074103		
0,500	4,72	3,35	1,06	1,34	1,85	0,39	M10X1	T1270-120/CAT50ADB-UNC	9074106		
0,625	4,72	3,35	1,06	1,34	1,97	0,39	M12X1	T1588-120/CAT50ADB-UNC	9074109		
0,750	4,72	3,35	1,30	1,65	2,05	0,39	M16X1	T1905-120/CAT50ADB-UNC	9074112		
1,250	4,72	3,35	1,73	2,09	2,44	0,39	M16X1	T3175-120/CAT50ADB-UNC	9074119		
0,250	6,30	4,92	0,83	1,26	1,42	0,39	M5	T0635-160/CAT50ADB-UNC	9074101		
0,375	6,30	4,92	0,94	1,34	1,65	0,39	M8X1	T0953-160/CAT50ADB-UNC	9074104		
0,500	6,30	4,92	1,06	1,65	1,85	0,39	M10X1	T1270-160/CAT50ADB-UNC	9074107		
0,625	6,30	4,92	1,06	1,65	1,97	0,39	M12X1	T1588-160/CAT50ADB-UNC	9074110		
0,750	6,30	4,92	1,30	2,01	2,05	0,39	M16X1	T1905-160/CAT50ADB-UNC	9074113		
1,000	6,30	4,92	1,73	2,36	2,44	0,39	M16X1	T2540-160/CAT50ADB-UNC	9074117		
1,250	6,30	4,92	1,73	2,36	2,44	0,39	M16X1	T3175-160/CAT50ADB-UNC	9074120		

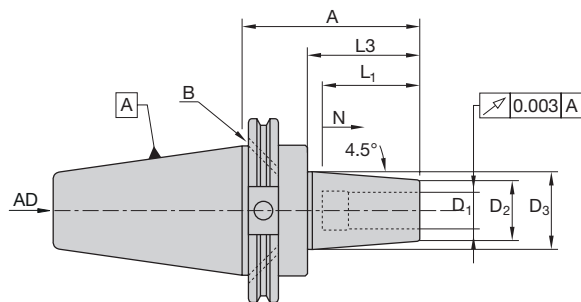

T... CAT 50								G2,5/ 25.000	≤ 3µm	max. 12.000	HSS
D1 [mm]	A [mm]	L3 [mm]	D2 [mm]	D3 [mm]	L1 [mm]	N [mm]	G	Bezeichnung Designation	Ident No.		
6	95	60	21	27	36	10	M5	T0600-95/CAT50ADB-UNC	9074144		
8	95	60	21	27	36	10	M6	T0800-95/CAT50ADB-UNC	9074147		
10	95	60	24	32	42	10	M8x1	T1000-95/CAT50ADB-UNC	9074150		
12	95	60	24	32	47	10	M10x1	T1200-95/CAT50ADB-UNC	9074153		
14	95	60	27	34	47	10	M10x1	T1400-95/CAT50ADB-UNC	9074156		
16	95	60	27	34	50	10	M12x1	T1600-95/CAT50ADB-UNC	9074160		
18	95	60	33	42	50	10	M12x1	T1800-95/CAT50ADB-UNC	9074163		
20	95	60	33	42	52	10	M16x1	T2000-95/CAT50ADB-UNC	9074166		
25	105	70	44	53	58	10	M16x1	T2500-105/CAT50ADB-UNC	9074170		
32	105	70	44	53	62	10	M16x1	T3200-105/CAT50ADB-UNC	9074173		
6	160	125	21	32	36	10	M5	T0600-160/CAT50ADB-UNC	9074146		
8	160	125	21	32	36	10	M6	T0800-160/CAT50ADB-UNC	9074149		
10	160	125	24	34	42	10	M8x1	T1000-160/CAT50ADB-UNC	9074152		
12	160	125	24	34	47	10	M10x1	T1200-160/CAT50ADB-UNC	9074155		
14	160	125	27	42	47	10	M10x1	T1400-160/CAT50ADB-UNC	9074159		
16	160	125	27	42	50	10	M12x1	T1600-160/CAT50ADB-UNC	9074162		
18	160	125	33	51	50	10	M12x1	T1800-160/CAT50ADB-UNC	9074165		
20	160	125	33	51	52	10	M16x1	T2000-160/CAT50ADB-UNC	9074168		
25	160	125	44	60	58	10	M16x1	T2500-160/CAT50ADB-UNC	9074172		
32	160	125	44	60	62	10	M16x1	T3200-160/CAT50ADB-UNC	9074175		

THD... CAT..., ANSI B5.50

Verstärkte Schrumpffutter Heavy Duty Shrink Chucks

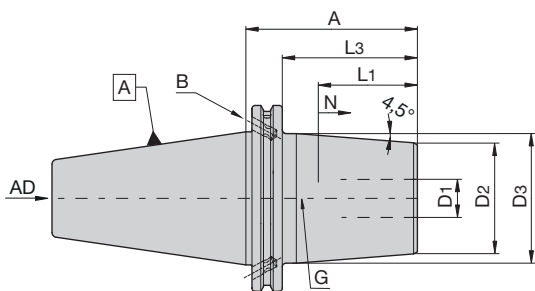

THD... CAT40 – Inch								G2,5/ 25.000	≤ 3µm	max. 12.000	HSS
D1 [Inch]	A [Inch]	L3 [Inch]	D2 [Inch]	D3 [Inch]	L1 [Inch]	N [Inch]	G	Bezeichnung Designation	Ident No.		
0.625	4.33	3.58	1.97	2.36	1.97	0.39	M12x1	THD1588-110/CAT40ADB-UNC	5057676		
0.750	4.33	3.58	2.28	2.68	2.05	0.39	M16x1	THD1905-110/CAT40ADB-UNC	5057677		

Hinweis zu THD Futter siehe Seite 10 Note for THD chucks, have a look at page 10

THD... CAT50 – Inch								G2,5/ 25.000	≤ 3µm	max. 12.000	HSS
D1 [Inch]	A [Inch]	L3 [Inch]	D2 [Inch]	D3 [Inch]	L1 [Inch]	N [Inch]	G	Bezeichnung Designation	Ident No.		
0.625	4.33	3.58	1.97	2.36	1.97	0.39	M12x1	THD1588-110/CAT50ADB-UNC	–		
0.750	4.33	3.58	2.28	2.68	2.05	0.39	M12x1	THD1905-110/CAT50ADB-UNC	–		
1.000	4.33	3.58	2.52	2.99	2.44	0.39	M16x1	THD2540-110/CAT50ADB-UNC	5057678		
1.250	4.33	3.58	2.83	3.35	2.44	0.39	M16x1	THD3175-110/CAT50ADB-UNC	5057679		

Hinweis zu THD Futter siehe Seite 10 Note for THD chucks, have a look at page 10

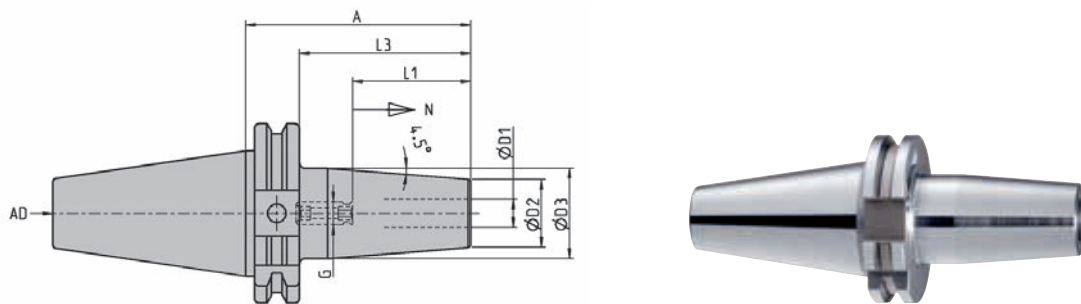

T... AD30 (Alt/Old: DIN69871)								G2,5/ 25.000	≤ 3µm	max. 20.000	HSS
D1 [mm]	A [mm]	L3 [mm]	D2 [mm]	D3 [mm]	L1 [mm]	N [mm]	G	Bezeichnung Designation	Ident No.		
6	71	52	21	27	36	10	M5	T0600-71/AD30	5038916		
8	71	52	21	27	36	10	M6	T0800-71/AD30	5038934		
10	71	52	24	32	42	10	M8x1	T1000-71/AD30	5038935		
12	71	52	24	32	47	10	M10x1	T1200-71/AD30	5038936		
16	71	52	27	34	50	10	M12x1	T1600-71/AD30	5038938		
3	80	61	15	20	20	5	M6	T0300-80/AD30	9076052		
4	80	61	15	20	20	5	M6	T0400-80/AD30	9076053		
5	80	61	15	20	25	5	M6	T0500-80/AD30	9101810		
6	80	61	21	27	36	10	M5	T0600/AD30	6727264		
8	80	61	21	27	36	10	M6	T0800/AD30	6727265		
10	80	61	24	32	42	10	M8x1	T1000/AD30	6727266		
12	80	61	24	32	47	10	M10x1	T1200/AD30	6727272		
14	80	61	27	34	47	10	M10x1	T1400/AD30	6727261		
16	80	61	27	34	50	10	M12x1	T1600/AD30	9118789		
18	80	61	33	42	50	10	M12x1	T1800/AD30	9118792		
20	80	61	33	42	52	10	M16x1	T2000/AD30	9118795		
3	120	101	15	20	20	5	M6	T0300-120/AD30	-		
4	120	101	15	20	20	5	M6	T0400-120/AD30	5038939		
5	120	101	15	20	25	5	M6	T0500-120/AD30	-		
6	120	101	21	27	36	10	M5	T0600-120/AD30	9118796		
8	120	101	21	27	36	10	M6	T0800-120/AD30	9118801		
10	120	101	24	32	42	10	M8x1	T1000-120/AD30	9118803		
12	120	101	24	32	47	10	M10x1	T1200-120/AD30	9118813		
16	120	101	27	34	50	10	M12x1	T1600-120/AD30	9118814		

Anzugsbolzen siehe Seite 89 Pull stud see page 89

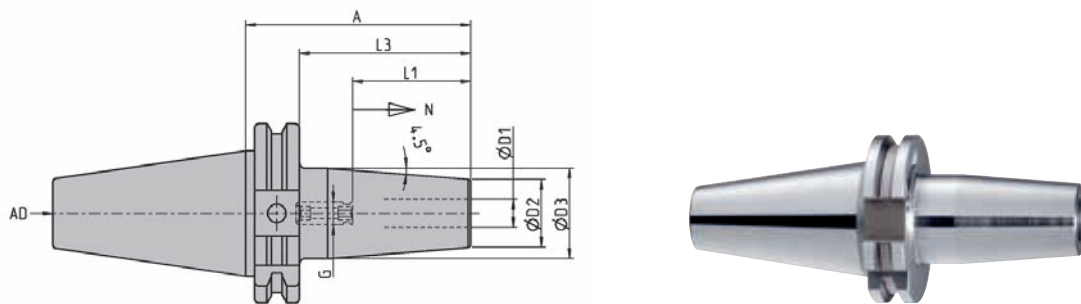

T... AD40 (Alt/Old: DIN 69871)									G2,5/25.000	≤ 3µm	max. 18.000	HSS
D1 [mm]	A [mm]	L3 [mm]	D2 [mm]	D3 [mm]	L1 [mm]	N [mm]	G	Bezeichnung Designation	Ident No.			
3	80	61	15	20	20	5	M6	T0300/AD40	6726852			
4	80	61	15	20	20	5	M6	T0400/AD40	6726537			
5	80	61	15	20	25	5	M6	T0500/AD40	6726538			
6	80	61	21	27	36	10	M5	T0600/AD40	6726193			
8	80	61	21	27	36	10	M6	T0800/AD40	6726194			
10	80	61	24	32	42	10	M8x1	T1000/AD40	6726195			
12	80	61	24	32	47	10	M10x1	T1200/AD40	6726196			
14	80	61	27	34	47	10	M10x1	T1400/AD40	6726276			
16	80	61	27	34	50	10	M12x1	T1600/AD40	6726197			
18	80	61	33	42	50	10	M12x1	T1800/AD40	6726277			
20	80	61	33	42	52	10	M16x1	T2000/AD40	6726198			
25	100	81	44	50	58	10	M16x1	T2500/AD40	6726199			
32	100	81	44	50	62	10	M16x1	T3200/AD40	6726278			
6	120	101	21	27	36	10	M5	T0600-120/AD40	6726832			
8	120	101	21	27	36	10	M6	T0800-120/AD40	9073978			
10	120	101	24	32	42	10	M8x1	T1000-120/AD40	9074612			
12	120	101	24	32	47	10	M10x1	T1200-120/AD40	9074772			
14	120	101	27	34	47	10	M10x1	T1400-120/AD40	9074773			
16	120	101	27	34	50	10	M12x1	T1600-120/AD40	9074775			
18	120	101	33	42	50	10	M12x1	T1800-120/AD40	6727044			
20	120	101	33	42	52	10	M16x1	T2000-120/AD40	9074778			
6	160	141	21	32	36	10	M5	T0600-160/AD40	6726829			
8	160	141	21	32	36	10	M6	T0800-160/AD40	9074611			
10	160	141	24	34	42	10	M8x1	T1000-160/AD40	6726830			
12	160	141	24	34	47	10	M10x1	T1200-160/AD40	6726831			
14	160	141	27	42	47	10	M10x1	T1400-160/AD40	9074774			
16	160	141	27	42	50	10	M12x1	T1600-160/AD40	9074776			
18	160	141	33	50	50	10	M12x1	T1800-160/AD40	9074777			
20	160	141	33	50	52	10	M16x1	T2000-160/AD40	9074779			

Anzugsbolzen siehe Seite 89 Pull stud see page 89

T....-...-C1-...AD40 / Cool Jet

Cool Jet Schrumpffutter Shrink Chucks

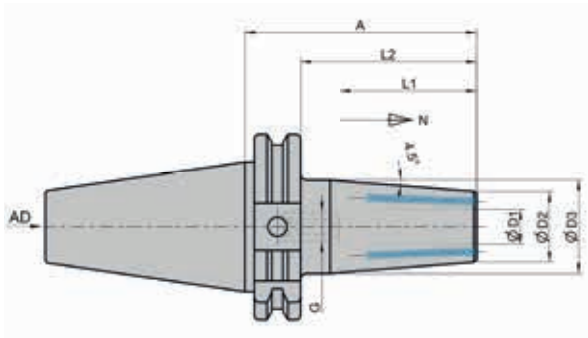

T....-...-C1-AD40									G2,5/ 25.000	≤ 3µm	max. 18.000	HSS
D1 [mm]	A [mm]	L3 [mm]	D2 [mm]	D3 [mm]	L1 [mm]	N [mm]	G	Bezeichnung Designation	Ident No.			
3	80	61	15	20	20	5	M6	T0300-80-C1-AD40	5150243			
4	80	61	15	20	20	5	M6	T0400-80-C1-AD40	5150348			
5	80	61	15	20	25	5	M6	T0500-80-C1-AD40	5150349			
6	80	61	21	27	36	10	M5	T0600-80-C1-AD40	5150350			
8	80	61	21	27	36	10	M6	T0800-80-C1-AD40	5150351			
10	80	61	24	32	42	10	M8 x1	T1000-80-C1-AD40	5150352			
12	80	61	24	32	47	10	M10 x1	T1200-80-C1-AD40	5150353			
14	80	61	27	34	47	10	M10 x1	T1400-80-C1-AD40	5150354			
16	80	61	27	34	50	10	M12 x1	T1600-80-C1-AD40	5150356			
18	80	61	33	42	50	10	M12 x1	T1800-80-C1-AD40	5150357			
20	80	61	33	42	52	10	M16 x1	T2000-80-C1-AD40	5150358			
25	100	81	44	50	58	10	M16 x1	T2500-100-C1-AD40	5150359			
32	100	81	44	50	62	10	M16 x1	T3200-100-C1-AD40	5150360			
6	120	101	21	27	36	10	M5	T0600-120-C1-AD40	5150365			
8	120	101	21	27	36	10	M6	T0800-120-C1-AD40	5150367			
10	120	101	24	32	42	10	M8 x1	T1000-120-C1-AD40	5150368			
12	120	101	24	32	47	10	M10 x1	T1200-120-C1-AD40	5150369			
14	120	101	27	34	47	10	M10 x1	T1400-120-C1-AD40	5150370			
16	120	101	27	34	50	10	M12 x1	T1600-120-C1-AD40	5150371			
18	120	101	33	42	50	10	M12 x1	T1800-120-C1-AD40	5150373			
20	120	101	33	42	52	10	M16 x1	T2000-120-C1-AD40	5150374			
6	160	141	21	32	36	10	M5	T0600-160-C1-AD40	5150375			
8	160	141	21	32	36	10	M6	T0800-160-C1-AD40	5150376			
10	160	141	24	34	42	10	M8 x1	T1000-160-C1-AD40	5150378			
12	160	141	24	34	47	10	M10 x1	T1200-160-C1-AD40	5150380			
14	160	141	27	42	47	10	M10 x1	T1400-160-C1-AD40	5150383			
16	160	141	27	42	50	10	M12 x1	T1600-160-C1-AD40	5150385			
18	160	141	33	50	50	10	M12 x1	T1800-160-C1-AD40	5150387			
20	160	141	33	50	52	10	M16 x1	T2000-160-C1-AD40	5150389			

Anzugsbolzen siehe Seite 89 Pull stud see page 89

Cool-Jet Ausführung

- für optional externe Kühlung
- 2 verschließbare Kühlkanalbohrungen
- optional mit 4 Kühlkanalbohrungen

Cool-Jet execution

- for optional external cooling
- 2 closable cooling channel holes
- Optionally with 4 cooling channel holes



*Hinweis Wuchtgüte siehe Seite 14 Balancing Information, page 14

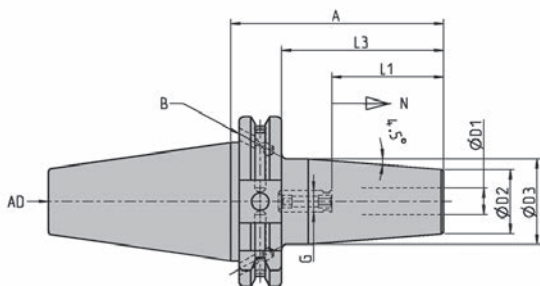

T... ADF40 (Alt/Old: ADB40 DIN 69871) G2,5/25.000 $\leq 3\mu\text{m}$ max. 18.000 HSS

D1 [mm]	A [mm]	L3 [mm]	D2 [mm]	D3 [mm]	L1 [mm]	N [mm]	G	Bezeichnung Designation	Ident No.
3	80	61	15	20	20	5	M6	T0300/ADB40	6727758
4	80	61	15	20	20	5	M6	T0400/ADB40	6727760
5	80	61	15	20	25	5	M6	T0500/ADB40	6727759
6	80	61	21	27	36	10	M5	T0600/ADB40	6727671
8	80	61	21	27	36	10	M6	T0800/ADB40	6727677
10	80	61	24	32	42	10	M8x1	T1000/ADB40	6727683
12	80	61	24	32	47	10	M10x1	T1200/ADB40	6727688
14	80	61	27	34	47	10	M10x1	T1400/ADB40	6727696
16	80	61	27	34	50	10	M12x1	T1600/ADB40	6727702
18	80	61	33	42	50	10	M12x1	T1800/ADB40	6727708
20	80	61	33	42	52	10	M16x1	T2000/ADB40	6727711
25	100	81	44	50	58	10	M16x1	T2500/ADB40	6727717

Anzugsbolzen siehe Seite 89 Pull stud see page 89

Coming soon
The new Bilz Shop.

Sie erreichen unseren neuen Shop bald unter www.Bilz.de
 You will reach the new shop under www.Bilz.com

TSF... AD40, DIN ISO7388-1
Schlanke Schrumpffutter Slim Shrink Chucks

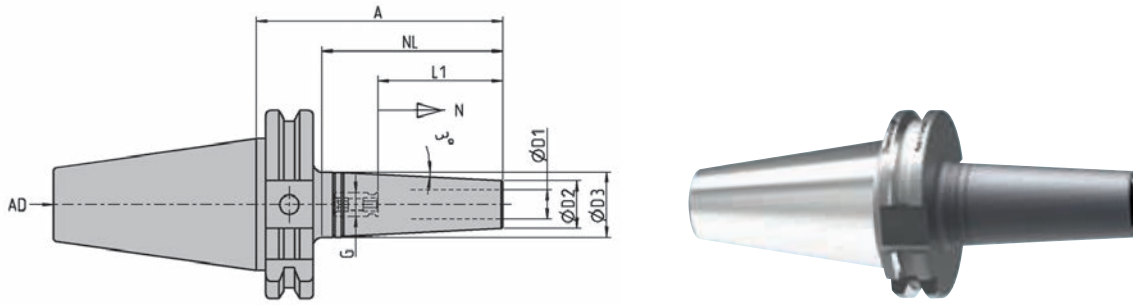

TSF-AD40 (Alt/Old: DIN 69871)									G2.5/ 25.000	≤ 3 μm	max. 18.000	coated	
D1 [mm]	A [mm]	NL [mm]	D2 [mm]	D3 [mm]	L1 [mm]	N [mm]	G	Bezeichnung Designation	Ident No.				
3	83	60	9	13	20	5	M6	TSF0300-60/AD40	9101227				
4	83	60	10	14	20	5	M6	TSF0400-60/AD40	9101238				
6	83	60	12	18	36	5	M5	TSF0600-60/AD40	9079018				
8	83	60	14	20	36	5	M6	TSF0800-60/AD40	9079023				
10	83	60	16	22	42	5	M8x1	TSF1000-60/AD40	9079026				
12	83	60	18	24	47	5	M10x1	TSF1200-60/AD40	9079029				
16	83	60	22	28	50	5	M12x1	TSF1600-60/AD40	9079032				
3	123	100	9	16	20	5	M6	TSF0300-100/AD40	9108372				
4	123	100	10	17	20	5	M6	TSF0400-100/AD40	9108373				
6	123	100	12	22	36	5	M5	TSF0600-100/AD40	9079021				
8	123	100	14	24	36	5	M6	TSF0800-100/AD40	9079024				
10	123	100	16	26	42	5	M8x1	TSF1000-100/AD40	9079027				
12	123	100	18	28	47	5	M10x1	TSF1200-100/AD40	9079030				
16	123	100	22	32	50	5	M12x1	TSF1600-100/AD40	9079033				
6	163	140	12	26	36	5	M5	TSF0600-140/AD40	9079022				
8	163	140	14	28	36	5	M6	TSF0800-140/AD40	9079025				
10	163	140	16	30	42	5	M8x1	TSF1000-140/AD40	9079028				
12	163	140	18	32	47	5	M10x1	TSF1200-140/AD40	9079031				
16	163	140	22	36	50	5	M12x1	TSF1600-140/AD40	9079034				
TSF Wechselscheiben siehe Zubehör Seite 92 TSF discs, see accessories page 92													
Anzugsbolzen siehe Seite 89 Pull stud see page 89													

*Hinweis Wuchtgüte siehe Seite 14 Balancing Information, page 14

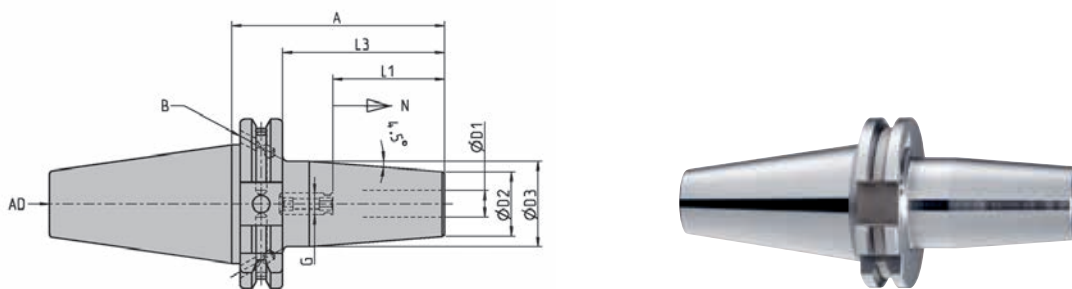

T... ADF50 (Alt/Old: ADB 50 DIN 69871)

G2,5/
25.000

≤ 3µm

max.
12.000

HSS

D1 [mm]	A [mm]	L3 [mm]	D2 [mm]	D3 [mm]	L1 [mm]	N [mm]	G	Bezeichnung Designation	Ident No.
6	80	61	21	27	36	10	M5	T0600/ADB50	6727617
8	80	61	21	27	36	10	M6	T0800/ADB50	6727615
10	80	61	24	32	42	10	M8x1	T1000/ADB50	6727624
12	80	61	24	32	47	10	M10x1	T1200/ADB50	6727630
14	80	61	27	34	47	10	M10x1	T1400/ADB50	6727639
16	80	61	27	34	50	10	M12x1	T1600/ADB50	6727645
18	80	61	33	42	50	10	M12x1	T1800/ADB50	6727649
20	80	61	33	42	52	10	M16x1	T2000/ADB50	6727653
25	90	71	44	53	58	10	M16x1	T2500/ADB50	6727658
32	90	71	44	53	62	10	M16x1	T3200/ADB50	6727665
6	120	101	21	27	36	10	M5	T0600-120/ADB50	6727618
8	120	101	21	27	36	10	M6	T0800-120/ADB50	6727616
10	120	101	24	32	42	10	M8x1	T1000-120/ADB50	6727625
12	120	101	24	32	47	10	M10x1	T1200-120/ADB50	6727631
14	120	101	27	34	47	10	M10x1	T1400-120/ADB50	6727640
16	120	101	27	34	50	10	M12x1	T1600-120/ADB50	6727603
18	120	101	33	42	50	10	M12x1	T1800-120/ADB50	6727650
20	120	101	33	42	52	10	M16x1	T2000-120/ADB50	6727654
25	120	101	44	53	58	10	M16x1	T2500-120/ADB50	6727661
32	120	101	44	53	62	10	M16x1	T3200-120/ADB50	6727667
6	160	141	21	32	36	10	M5	T0600-160/ADB50	6727612
8	160	141	21	32	36	10	M6	T0800-160/ADB50	6727621
10	160	141	24	34	42	10	M8x1	T1000-160/ADB50	6727627
12	160	141	24	34	47	10	M10x1	T1200-160/ADB50	6727633
14	160	141	27	42	47	10	M10x1	T1400-160/ADB50	6727642
16	160	141	27	42	50	10	M12x1	T1600-160/ADB50	6727647
18	160	141	33	51	50	10	M12x1	T1800-160/ADB50	6727651
20	160	141	33	51	52	10	M16x1	T2000-160/ADB50	6727656
25	160	141	44	60	58	10	M16x1	T2500-160/ADB50	6727663
32	160	141	44	60	62	10	M16x1	T3200-160/ADB50	6727669
6	200	181	21	32	36	10	M5	T0600-200-K1-ADF50	5017434
8	200	181	21	32	36	10	M6	T0800-200-K1-ADF50	5134248
10	200	181	24	34	42	10	M8x1	T1000-200-K1-ADF50	5134249
12	200	181	24	34	47	10	M10x1	T1200-200-K1-ADF50	5134250
14	200	181	27	42	47	10	M10x1	T1400-200-K1-ADF50	5134251
16	200	181	27	42	50	10	M12x1	T1600-200-K1-ADF50	5017436
18	200	181	33	51	50	10	M12x1	T1800-200-K1-ADF50	5017439
20	200	181	33	51	52	10	M16x1	T2000-200-K1-ADF50	5134252
25	200	181	44	60	58	10	M16x1	T2500-200-K1-ADF50	5134253
32	200	181	44	60	62	10	M16x1	T3200-200-K1-ADF50	5134254

Anzugsbolzen siehe Seite 89 Pull stud see page 89

T....-C1-...ADF50/ Cool Jet

Cool Jet Schrumpffutter Shrink Chucks

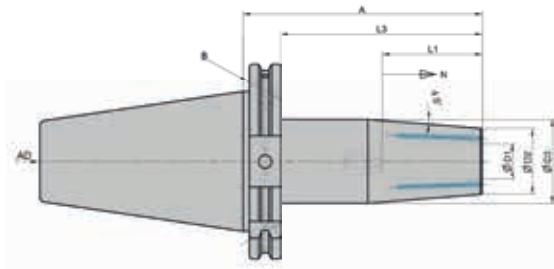

T....-C1-ADF50									G2,5/ 25.000	≤ 3µm	max. 12.000	HSS
D1 [mm]	A [mm]	L3 [mm]	D2 [mm]	D3 [mm]	L1 [mm]	N [mm]	G	Bezeichnung Designation	Ident No.			
6	80	61	21	27	36	10	M5	T0600-80-C1-ADF50	5150418			
8	80	61	21	27	36	10	M6	T0800-80-C1-ADF50	5150419			
10	80	61	24	32	42	10	M8 x1	T1000-80-C1-ADF50	5150420			
12	80	61	24	32	47	10	M10 x1	T1200-80-C1-ADF50	5150421			
14	80	61	27	34	47	10	M10 x1	T1400-80-C1-ADF50	5150422			
16	80	61	27	34	50	10	M12 x1	T1600-80-C1-ADF50	5150423			
18	80	61	33	42	50	10	M12 x1	T1800-80-C1-ADF50	5150424			
20	80	61	33	42	52	10	M16 x1	T2000-80-C1-ADF50	5150425			
25	90	71	44	53	58	10	M16 x1	T2500-90-C1-ADF50	5150426			
32	90	71	44	53	62	10	M16 x1	T3200-90-C1-ADF50	5150427			
6	120	101	21	27	36	10	M5	T0600-120-C1-ADF50	5150428			
8	120	101	21	27	36	10	M6	T0800-120-C1-ADF50	5150432			
10	120	101	24	32	42	10	M8 x1	T1000-120-C1-ADF50	5150434			
12	120	101	24	32	47	10	M10 x1	T1200-120-C1-ADF50	5150435			
14	120	101	27	34	47	10	M10 x1	T1400-120-C1-ADF50	5150437			
16	120	101	27	34	50	10	M12 x1	T1600-120-C1-ADF50	5150438			
18	120	101	33	42	50	10	M12 x1	T1800-120-C1-ADF50	5150439			
20	120	101	33	42	52	10	M16 x1	T2000-120-C1-ADF50	5150440			
25	120	101	44	53	58	10	M16 x1	T2500-120-C1-ADF50	5150441			
32	120	101	44	53	62	10	M16 x1	T3200-120-C1-ADF50	5150442			
6	160	141	21	32	36	10	M5	T0600-160-C1-ADF50	5150444			
8	160	141	21	32	36	10	M6	T0800-160-C1-ADF50	5150445			
10	160	141	24	34	42	10	M8 x1	T1000-160-C1-ADF50	5150447			
12	160	141	24	34	47	10	M10 x1	T1200-160-C1-ADF50	5150448			
14	160	141	27	42	47	10	M10 x1	T1400-160-C1-ADF50	5150450			
16	160	141	27	42	50	10	M12 x1	T1600-160-C1-ADF50	5150451			
18	160	141	33	51	50	10	M12 x1	T1800-160-C1-ADF50	5150453			
20	160	141	33	51	52	10	M16 x1	T2000-160-C1-ADF50	5150454			
25	160	141	44	60	58	10	M16 x1	T2500-160-C1-ADF50	5150455			
32	160	141	44	60	62	10	M16 x1	T3200-160-C1-ADF50	5150457			

Anzugsbolzen siehe Seite 89 Pull stud see page 89

Cool-Jet Ausführung

- für optional externe Kühlung
- 2 verschließbare Kühlkanalbohrungen
- optional mit 4 Kühlkanalbohrungen

Cool-Jet execution

- for optional external cooling
- 2 closable cooling channel holes
- Optionally with 4 cooling channel holes



*Hinweis Wuchtgüte siehe Seite 14 Balancing Information, page 14

THD... ADF50, DIN ISO7388-1

Verstärkte Schrumpffutter Heavy Duty Shrink Chucks

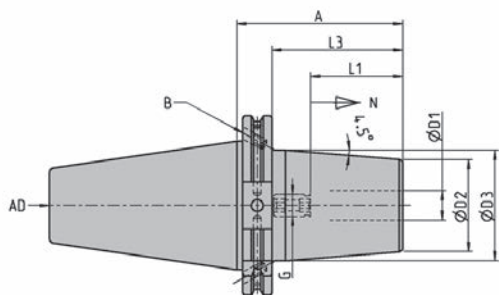

THD-ADF50 (Alt/Old: ADB50 DIN69871)								G2,5/ 25.000	≤ 3µm	max. 12.000	HSS
D1 [mm]	A [mm]	L3 [mm]	D2 [mm]	D3 [mm]	L1 [mm]	N [mm]	G	Bezeichnung Designation	Ident No.		
16	90	70,9	50	60	50	10	M12x1	THD1600-90/ADB50	5031169		
20	90	70,9	58	68	52	10	M16x1	THD2000-90/ADB50	5031171		
25	90	70,9	64	74	58	10	M16x1	THD2500-90/ADB50	5031173		
32	110	90,9	72	85	62	10	M16x1	THD3200-110/ADB50	5031174		

Anzugsbolzen siehe Seite 89 **Pull stud** see page 89

Hinweis zu THD Futter siehe Seite 10 **Note for THD chucks, have a look at page 10**

M....-...-C1-FBT30

Cool Jet Schrumpffutter mit Plananlage
Cool Jet Shrink Chucks with face contact

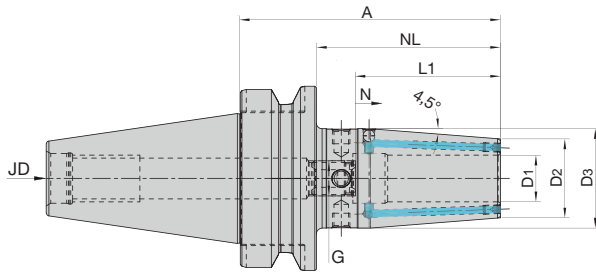

M....-...-C1-FBT30									G2,5/ 25.000	≤ 3µm	50
D1 (mm)	A (mm)	D 2 (mm)	D 3 (mm)	L1 (mm)	L3 (mm)	N (mm)	G	Bezeichnung Designation	Ident No.		
3	80	10	18	20	58			M0300-80-C1-FBT30	5169901		
4	80	10	18	20	58			M0400-80-C1-FBT30	5169903		
5	80	15	20	36	58			M0500-80-C1-FBT30	5169904		
6	80	21	27	36	58	8,5	M5	M0600-80-C1-FBT30	5169525		
8	80	21	27	36	58	9,5	M6	M0800-80-C1-FBT30	5169528		
10	80	24	32	42	58	9,5	M8x1	M1000-80-C1-FBT30	5169529		
12	80	24	32	47	58	13	M10x1	M1200-80-C1-FBT30	5169530		
14	80	27	34	47	58	13	M10x1	M1400-80-C1-FBT30	5169532		
16	80	27	34	50	58	13	M12x1	M1600-80-C1-FBT30	5169535		
18	90	33	42	50	68	13	M12x1	M1800-90-C1-FBT30	5169538		
20	90	33	42	52	68	13	M16x1	M2000-90-C1-FBT30	5169539		

Anzugsbolzen siehe Seite 89 Pull stud see page 89

Cool-Jet Ausführung

- für optional externe Kühlung
- 2 verschließbare Kühlkanalbohrungen
- optional mit 4 Kühlkanalbohrungen

Cool-Jet execution

- for optional external cooling
- 2 closable cooling channel holes
- Optionally with 4 cooling channel holes



M.....-C1-FBT40

Cool Jet Schrumpffutter mit Plananlage
Cool Jet Shrink Chucks with face contact

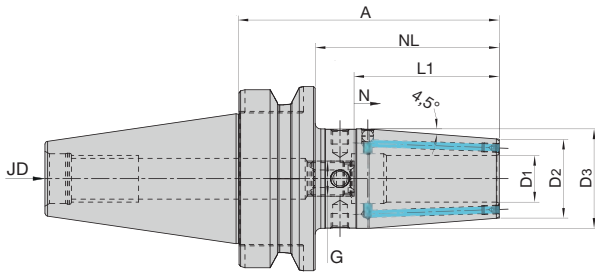

M.....-C1-FBT40									G2,5/25.000	≤ 3µm	50
D1 (mm)	A (mm)	D 2 (mm)	D 3 (mm)	L1 (mm)	L3 (mm)	N (mm)	G	Bezeichnung Designation	Ident No.		
3	90	10	18	20	63			M0300-90-C1-FBT40	5169905		
4	90	10	18	20	63			M0400-90-C1-FBT40	5169906		
5	90	15	20	36	63			M0500-90-C1-FBT40	5169907		
6	90	21	27	36	63	8,5	M5	M0600-90-C1-FBT40	5169540		
8	90	21	27	36	63	9,5	M6	M0800-90-C1-FBT40	5169543		
10	90	24	32	42	63	9,5	M8x1	M1000-90-C1-FBT40	5169544		
12	90	24	32	47	63	13	M10x1	M1200-90-C1-FBT40	5169545		
14	90	27	34	47	63	13	M10x1	M1400-90-C1-FBT40	5169547		
16	90	27	34	50	63	13	M12x1	M1600-90-C1-FBT40	5169548		
18	90	33	42	50	63	13	M12x1	M1800-90-C1-FBT40	5169549		
20	90	33	42	52	63	13	M16x1	M2000-90-C1-FBT40	5169553		
25	100	44	52,5	58	73	13	M16x1	M2500-100-C1-FBT40	5169555		
32	100	44	53	58	73	13	M16x1	M3200-100-C1-FBT40	5169559		

M.....-C1-FBT40									G2,5/25.000	≤ 3µm	50
D1 (mm)	A (mm)	D 2 (mm)	D 3 (mm)	L1 (mm)	L3 (mm)	N (mm)	G	Bezeichnung Designation	Ident No.		
6	130	21	27	36	104	8,5	M5	M0600-130-C1-FBT40	5169560		
8	130	21	27	36	104	9,5	M6	M0800-130-C1-FBT40	5169561		
10	130	24	32	42	104	9,5	M8x1	M1000-130-C1-FBT40	5169562		
12	130	24	32	47	104	13	M10x1	M1200-130-C1-FBT40	5169564		
14	130	27	34	47	104	13	M10x1	M1400-130-C1-FBT40	5169565		
16	130	27	34	50	104	13	M12x1	M1600-130-C1-FBT40	5169567		
18	130	33	42	50	104	13	M12x1	M1800-130-C1-FBT40	5169573		
20	130	33	42	52	104	13	M16x1	M2000-130-C1-FBT40	5169577		
25	130	44	52,5	58	104	13	M16x1	M2500-130-C1-FBT40	5169579		
32	130	44	53	58	104	13	M16x1	M3200-130-C1-FBT40	5169580		

M.....-C1-FBT40									G2,5/25.000	≤ 3µm	50
D1 (mm)	A (mm)	D 2 (mm)	D 3 (mm)	L1 (mm)	L3 (mm)	N (mm)	G	Bezeichnung Designation	Ident No.		
6	160	21	27	36	134	8,5	M5	M0600-160-C1-FBT40	5169696		
8	160	21	27	36	134	9,5	M6	M0800-160-C1-FBT40	5169697		
10	160	24	32	42	134	9,5	M8x1	M1000-160-C1-FBT40	5169703		
12	160	24	32	47	134	13	M10x1	M1200-160-C1-FBT40	5169707		
14	160	27	34	47	134	13	M10x1	M1400-160-C1-FBT40	5169708		
16	160	27	34	50	134	13	M12x1	M1600-160-C1-FBT40	5169709		
18	160	33	42	50	134	13	M12x1	M1800-160-C1-FBT40	5169710		
20	160	33	42	52	134	13	M16x1	M2000-160-C1-FBT40	5169714		
25	160	44	52,5	58	134	13	M16x1	M2500-160-C1-FBT40	5169716		
32	160	44	53	58	134	13	M16x1	M3200-160-C1-FBT40	5169717		

Anzugsbolzen siehe Seite 89 Pull stud see page 89
Hinweis zu THD Futter siehe Seite 10 Note for THD chucks, have a look at page 10

MSF....-...-FBT40

Schrumpffutter mit Plananlage
Shrink Chucks with face contact

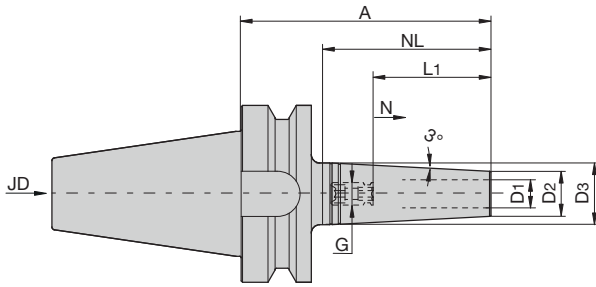

MSF....-...-FBT40									G2,5/ 25.000	≤ 3µm	50
D1 [mm]	A [mm]	D 2 [mm]	D 3 [mm]	L1 [mm]	NL [mm]	N [mm]	G	Bezeichnung Designation	Ident No.		
3	90	9	13	20	63			MSF0300-90-FBT40	5126719		
4	90	10	14	20	63			MSF0400-90-FBT40	5126720		
6	90	12	18	36	63	8,5	M5	MSF0600-90-FBT40	5126723		
8	90	14	20	36	63	9,5	M6	MSF0800-90-FBT40	5126725		
10	90	16	22	42	63	9,5	M8x1	MSF1000-90-FBT40	5126726		
12	90	18	24	47	63	13	M10x1	MSF1200-90-FBT40	5126729		
16	90	22	28	50	63	13	M12x1	MSF1600-90-FBT40	5126732		
20	90	27	33	52	63	13	M16x1	MSF2000-90-FBT40	5126733		

Anzugsbolzen siehe Seite 89 Pull stud see page 89

THD... JD 50, DIN ISO7388-2

Verstärkte Schrumpffutter Heavy Duty Shrink Chucks

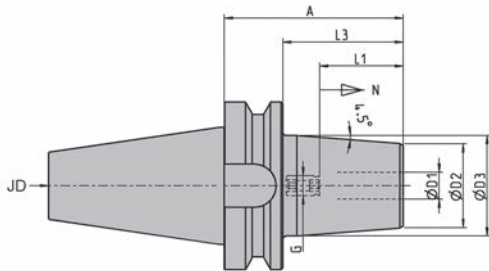

THD-JD50 (Alt/Old: BT50, MAS403)									G2,5/ 25.000	≤ 3µm	max. 12.000	HSS
D1 [mm]	A [mm]	L3 [mm]	D2 [mm]	D3 [mm]	L1 [mm]	N [mm]	G	Bezeichnung Designation	Ident No.			
16	110	72	50	60	50	10	M12x1	THD1600-110/BT50	5031175			
20	110	72	58	68	52	10	M16x1	THD2000-110/BT50	5031176			
25	110	72	64	74	58	10	M16x1	THD2500-110/BT50	5031177			
32	130	92	72	85	62	10	M16x1	THD3200-130/BT50	5031178			

Anzugsbolzen siehe Seite 89 Pull stud see page 89

Hinweis zu THD Futter siehe Seite 10 Note for THD chucks, have a look at page 10

M....-...-C1-FBT50

Cool Jet Schrumpffutter mit Plananlage
Cool Jet Shrink Chucks with face contact

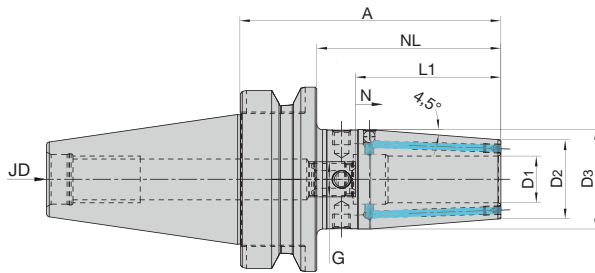

M....-...-C1-FBT50									G2,5/ 25.000	≤ 3µm	50
D1 (mm)	A (mm)	D 2 (mm)	D 3 (mm)	L1 (mm)	L3 (mm)	N (mm)	G	Bezeichnung Designation	Ident No.		
6	100	21	27	36	62	8,5	M5	M0600-100-C1-FBT50	5169776		
8	100	21	27	36	62	9,5	M6	M0800-100-C1-FBT50	5169778		
10	100	24	32	42	62	9,5	M8x1	M1000-100-C1-FBT50	5169781		
12	100	24	32	47	62	13	M10x1	M1200-100-C1-FBT50	5169783		
14	100	27	34	47	62	13	M10x1	M1400-100-C1-FBT50	5170765		
16	100	27	34	50	62	13	M12x1	M1600-100-C1-FBT50	5170766		
18	100	33	42	50	62	13	M12x1	M1800-100-C1-FBT50	5170767		
20	100	33	42	52	62	13	M16x1	M2000-100-C1-FBT50	5170768		
25	100	44	52,5	58	62	13	M16x1	M2500-100-C1-FBT50	5170770		
6	130	21	27	36	92	8,5	M5	M0600-130-C1-FBT50	5170777		
8	130	21	27	36	92	9,5	M6	M0800-130-C1-FBT50	5170781		
10	130	24	32	42	92	9,5	M8x1	M1000-130-C1-FBT50	5170782		
12	130	24	32	47	92	13	M10x1	M1200-130-C1-FBT50	5170783		
14	130	27	34	47	92	13	M10x1	M1400-130-C1-FBT50	5170784		
16	130	27	34	50	92	13	M12x1	M1600-130-C1-FBT50	5170785		
18	130	33	42	50	92	13	M12x1	M1800-130-C1-FBT50	5170786		
20	130	33	42	52	92	13	M16x1	M2000-130-C1-FBT50	5170787		
25	130	44	52,5	58	92	13	M16x1	M2500-130-C1-FBT50	5170788		
32	130	44	53	58	92	13	M16x1	M3200-130-C1-FBT50	5170789		
6	160	21	27	36	122	8,5	M5	M0600-160-C1-FBT50	5170790		
8	160	21	27	36	122	9,5	M6	M0800-160-C1-FBT50	5170791		
10	160	24	32	42	122	9,5	M8x1	M1000-160-C1-FBT50	5170792		
12	160	24	32	47	122	13	M10x1	M1200-160-C1-FBT50	5170793		
14	160	27	34	47	122	13	M10x1	M1400-160-C1-FBT50	5170794		
16	160	27	34	50	122	13	M12x1	M1600-160-C1-FBT50	5170795		
18	160	33	42	50	122	13	M12x1	M1800-160-C1-FBT50	5170796		
20	160	33	42	52	122	13	M16x1	M2000-160-C1-FBT50	5170797		
25	160	44	52,5	58	122	13	M16x1	M2500-160-C1-FBT50	5170798		
32	160	44	53	58	122	13	M16x1	M3200-160-C1-FBT50	5170799		

Anzugsbolzen siehe Seite 89 **Pull stud** see page 89
Hinweis zu THD Futter siehe Seite 10 **Note for THD chucks, have a look at page 10**

Cool-Jet Ausführung

- für optional externe Kühlung
- 2 verschließbare Kühlkanalbohrungen
- optional mit 4 Kühlkanalbohrungen

Cool-Jet execution

- for optional external cooling
- 2 closable cooling channel holes
- Optionally with 4 cooling channel holes



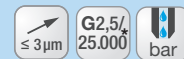
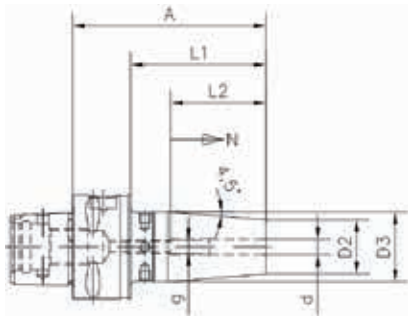

d (mm)	D 2 (mm)	D 3 (mm)	A (mm)	L1 (mm)	L2 (mm)	N (mm)	g	Bezeichnung Designation	Ident No.
6	21	27	75	55	36	10	M5	S0600-75/PSC40	5164524
8	12	17	75	55	36	10	M6	S0800-75/PSC40	5164525
10	12	17	75	55	42	10	M8x1	S1000-75/PSC40	5164526
12	21	27	80	60	47	10	M10x1	S1200-75/PSC40	5164527
14	21	27	80	60	47	10	M10x1	S1400-80/PSC40	5164528
16	24	32	80	60	50	10	M12x1	S1600-80/PSC40	5164532
18	24	32	80	60	50	10	M12x1	S1800-80/PSC40	5164535
20	27	34	85	65	52	10	M16x1	S2000-85/PSC40	5164541

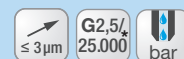

d (mm)	D 2 (mm)	D 3 (mm)	A (mm)	L1 (mm)	L2 (mm)	N (mm)	g	Bezeichnung Designation	Ident No.
8	21	27	75	55	36	10	M6	S0800-75/PSC50	5164549
10	24	32	75	55	42	10	M8x1	S1000-75/PSC50	5164551
12	24	32	80	60	47	10	M10x1	S1200-75/PSC50	5164555
14	27	34	80	60	47	10	M10x1	S1400-80/PSC50	5164557
16	27	34	80	60	50	10	M12x1	S1600-80/PSC50	5164581
18	33	42	80	60	50	10	M12x1	S1800-80/PSC50	5164582
20	33	42	85	65	52	10	M16x1	S2000-85/PSC50	5164583
25	44	53	90	70	58	10	M16x1	S2500-90/PSC50	5164585

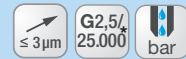
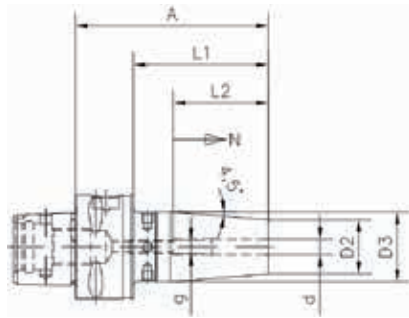

d (mm)	D 2 (mm)	D 3 (mm)	A (mm)	L1 (mm)	L2 (mm)	N (mm)	g	Bezeichnung Designation	Ident No.
3	12	17	80	58				S0300-80/PSC63	5164586
4	12	17	80	58				S0400-80/PSC63	5164587
5	12	17	80	58				S0500-80/PSC63	5164588
6	21	27	80	58	36	10	M5	S0600-80/PSC63	5164589
8	21	27	80	58	36	10	M6	S0800-80/PSC63	5164590
10	24	32	80	58	42	10	M8x1	S1000-80/PSC63	5164591
12	24	32	80	58	47	10	M10x1	S1200-80/PSC63	5164592
14	27	34	85	63	47	10	M10x1	S1400-80/PSC63	5164593
16	27	34	85	63	50	10	M12x1	S1600-85/PSC63	5164594
18	33	42	85	63	50	10	M12x1	S1800-85/PSC63	5164595
20	33	42	85	63	52	10	M16x1	S2000-85/PSC63	5164596
25	44	52	90	68	58	10	M16x1	S2500-90/PSC63	5164597
32	44	53	95	73	62	10	M16x1	S3200-95/PSC63	5164598
6	21	27	120	98	36	10	M5	S0600-120/PSC63	5164837
8	21	27	120	98	36	10	M6	S0800-120/PSC63	5164838
10	24	32	120	98	42	10	M8x1	S1000-120/PSC63	5164839
12	24	32	120	98	47	10	M10x1	S1200-120/PSC63	5164840
14	27	34	120	98	47	10	M10x1	S1400-120/PSC63	5164882
16	27	34	120	98	50	10	M12x1	S1600-120/PSC63	5164883
18	42	44	120	98	50	10	M12x1	S1800-120/PSC63	5164884
20	42	44	120	98	52	10	M16x1	S2000-120/PSC63	5164885
25	44	53	120	98	58	10	M16x1	S2500-120/PSC63	5164886
32	44	53	120	98	58	10	M16x1	S3200-120/PSC63	5164887
6	21	27	160	138	36	10	M5	S0600-160/PSC63	5165072
8	21	27	160	138	36	10	M6	S0800-160/PSC63	5165074
10	24	32	160	138	42	10	M8x1	S1000-160/PSC63	5165075
12	24	32	160	138	47	10	M10x1	S1200-160/PSC63	5165076
14	27	34	160	138	47	10	M10x1	S1400-160/PSC63	5165077
16	27	34	160	138	50	10	M12x1	S1600-160/PSC63	5165078
18	42	44	160	138	50	10	M12x1	S1800-160/PSC63	5165079
20	42	44	160	138	52	10	M16x1	S2000-160/PSC63	5165080
25	44	53	160	138	58	10	M16x1	S2500-160/PSC63	5165081
32	44	53	160	138	58	10	M16x1	S3200-160/PSC63	5165082

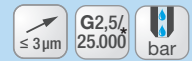
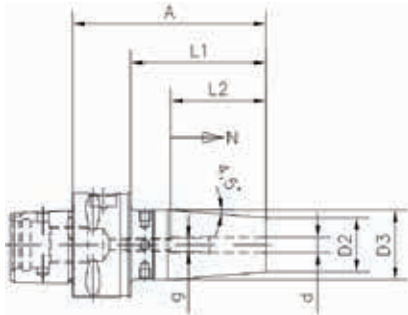

d (mm)	D 2 (mm)	D 3 (mm)	A (mm)	L1 (mm)	L2 (mm)	N (mm)	g	Bezeichnung Designation	Ident No.
6	21	27	80	50	36	10	M5	S0600-80/PSC80	5166408
8	21	27	80	50	36	10	M6	S0800-80/PSC80	5166409
10	24	32	80	50	42	10	M8x1	S1000-80/PSC80	5166410
12	24	32	80	50	47	10	M10x1	S1200-80/PSC80	5166411
14	27	34	85	55	47	10	M10x1	S1400-85/PSC80	5166412
16	27	34	85	55	50	10	M12x1	S1600-85/PSC80	5166413
18	42	44	85	55	50	10	M12x1	S1800-85/PSC80	5166414
20	42	44	85	55	52	10	M16x1	S2000-85/PSC80	5166415
25	44	53	90	60	58	10	M16x1	S2500-90/PSC80	5166416
32	44	53	95	65	58	10	M16x1	S3200-95/PSC80	5166417

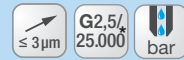
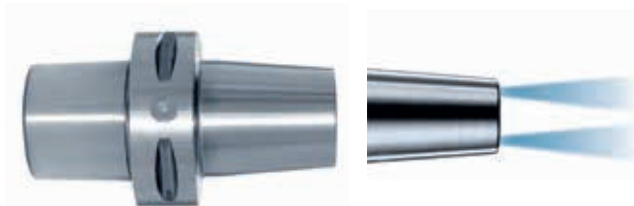
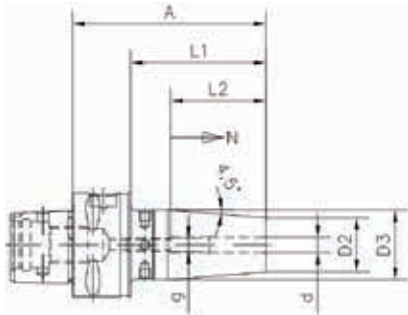

d (mm)	D 2 (mm)	D 3 (mm)	A (mm)	L1 (mm)	L2 (mm)	N (mm)	g	Bezeichnung Designation	Ident No.
6	21	27	80	58	36	10	M5	S0600-80-C1/PSC63	5164824
8	21	27	80	58	36	10	M6	S0800-80-C1/PSC63	5164826
10	24	32	80	58	42	10	M8x1	S1000-80-C1/PSC63	5164828
12	24	32	80	58	47	10	M10x1	S1200-80-C1/PSC63	5164829
14	27	34	85	63	47	10	M10x1	S1400-80-C1/PSC63	5164830
16	27	34	85	63	50	10	M12xw1	S1600-85-C1/PSC63	5164831
18	33	42	85	63	50	10	M12x1	S1800-85-C1/PSC63	5164833
20	33	42	85	63	52	10	M16x1	S2000-85-C1/PSC63	5166743
6	21	27	120	98	36	10	M5	S0600-120-C1/PSC63	5164888
8	21	27	120	98	36	10	M6	S0800-120-C1/PSC63	5164889
10	24	32	120	98	42	10	M8x1	S1000-120-C1/PSC63	5164890
12	24	32	120	98	47	10	M10x1	S1200-120-C1/PSC63	5164891
16	27	34	120	98	50	10	M12x1	S1600-120-C1/PSC63	5164892
20	42	44	120	98	52	10	M16x1	S2000-120-C1/PSC63	5164893

Cool-Jet Ausführung

- für optional externe Kühlung
- 2 verschließbare Kühlkanalbohrungen
- optional mit 4 Kühlkanalbohrungen

Cool-Jet execution

- for optional external cooling
- 2 closable cooling channel holes
- Optionally with 4 cooling channel holes



TSFV

Schlanke Schrumpferlängerungen Slim Shrink Chucks Extensions



Bild 1



Bild 2



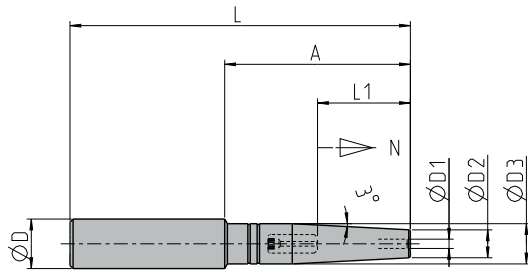

Bild 3

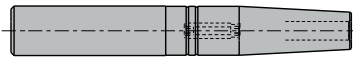

TSFV										
D1 [mm]	A [mm]	D [mm]	L [mm]	D2 [mm]	D3 [mm]	L1 [mm]	N [mm]	Bild Picture	Bezeichnung Designation	Ident No.
3	63	12	110	9	11,8	15	5	1	TSFV0300-110-K1-Z1200	5118180
4	63	12	110	10	11,8	15	5	1	TSFV0400-110-K1-Z1200	5118185
5	63	12	110	11	11,8	20	5	1	TSFV0500-110-K1-Z1200	5118191
6	63	12	110	12	17	36	10	3	TSFV0600-110-K1-Z1200	5118091
8	63	12	110	14	19	36	10	3	TSFV0800-110-K1-Z1200	5118104
3	60	16	110	9	13	15	5	1	TSFV0300-110-K1-Z1600	5118181
4	60	16	110	10	14	15	5	1	TSFV0400-110-K1-Z1600	5118186
5	60	16	110	11	15	20	5	1	TSFV0500-110-K1-Z1600	5118192
6	60	16	110	12	15,8	36	10	2	TSFV0600-110-K1-Z1600	5118092
8	60	16	110	14	19	36	10	3	TSFV0800-110-K1-Z1600	5118159
3	58	20	110	9	13	15	5	1	TSFV0300-110-K1-Z2000	5118182
4	58	20	110	10	14	15	5	1	TSFV0400-110-K1-Z2000	5118187
5	58	20	110	11	15	20	5	1	TSFV0500-110-K1-Z2000	5118194
6	58	20	110	12	16	36	10	1	TSFV0600-110-K1-Z2000	5118093
8	58	20	110	14	19	36	10	1	TSFV0800-110-K1-Z2000	5118160
10	58	20	110	16	19,8	42	10	1	TSFV1000-110-K1-Z2000	5118168
12	58	20	110	18	19,8	47	10	1	TSFV1200-110-K1-Z2000	5118173
TSFV										
3	113	12	160	9	11,8	20	5	1	TSFV0300-160-K1-Z1200	5146279
4	113	12	160	10	11,8	20	5	1	TSFV0400-160-K1-Z1200	5146281
3	110	16	160	9	13	20	5	1	TSFV0300-160-K1-Z1600	5146282
4	110	16	160	10	14	20	5	1	TSFV0400-160-K1-Z1600	5146283
5	110	16	160	11	15	25	5	1	TSFV0500-160-K1-Z1600	5146284
6	110	16	160	12	15,8	36	10	2	TSFV0600-160-K1-Z1600	5118094
5	110	20	160	11	15	25	5	1	TSFV0500-160-K1-Z2000	5146286
6	108	20	160	12	16	36	10	1	TSFV0600-160-K1-Z2000	5118095
8	108	20	160	14	19	36	10	1	TSFV0800-160-K1-Z2000	5146291
8	108	25	160	14	19	36	10	1	TSFV0800-160-K1-Z2500	5146292
10	108	25	160	16	21	42	10	1	TSFV1000-160-K1-Z2500	5146294
12	108	25	160	18	23	47	10	1	TSFV1200-160-K1-Z2500	5146296
14	108	25	160	20	24,8	47	10	1	TSFV1400-160-K1-Z2500	5146298
16	108	25	160	22	24,8	50	10	1	TSFV1600-160-K1-Z2500	5146299
10	98	32	160	16	21	42	10	1	TSFV1000-160-K1-Z3200	5146300
12	98	32	160	18	23	47	10	1	TSFV1200-160-K1-Z3200	5146301
14	98	32	160	20	25	47	10	1	TSFV1400-160-K1-Z3200	5146302
16	98	32	160	22	28	50	10	1	TSFV1600-160-K1-Z3200	5146304
18	98	32	160	25	30	50	10	1	TSFV1800-160-K1-Z3200	5146305
20	98	32	160	26	31,8	52	10	1	TSFV2000-160-K1-Z3200	5146306
 TSF Wechselscheiben siehe Zubehör Seite 92 TSF discs, see accessories page 92										

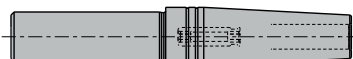
TSFV

Schlanke Schrumpferlängerungen Slim Shrink Chucks Extensions



Bild 1



Bild 2

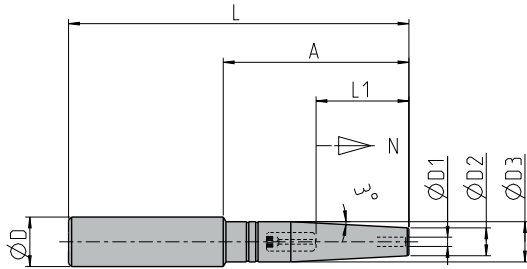

Bild 3

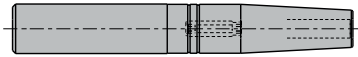

TSFV													
D1 [mm]	A [mm]	D [mm]	L [mm]	D2 [mm]	D3 [mm]	L1 [mm]	N [mm]	Bild Picture	Bezeichnung Designation	Ident No.			
3	150	16	200	9	13	15	5	1	TSFV0300-200-K1-Z1600	5118183			
4	150	16	200	10	14	15	5	1	TSFV0400-200-K1-Z1600	5118188			
5	150	16	200	11	15	20	5	1	TSFV0500-200-K1-Z1600	5118195			
6	150	16	200	12	15,8	36	10	1	TSFV0600-200-K1-Z1600	5118096			
8	150	16	200	14	19	36	10	3	TSFV0800-200-K1-Z1600	5118163			
6	198	20	250	12	16	36	10	1	TSFV0600-250-K1-Z2000	5118098			
8	198	20	250	14	19	36	10	1	TSFV0800-250-K1-Z2000	5118165			
10	198	20	250	16	19,8	42	10	1	TSFV1000-250-K1-Z2000	5118171			
12	192	25	250	18	23	47	10	1	TSFV1200-250-K1-Z2500	5118175			
16	192	25	250	22	28	50	10	1	TSFV1600-250-K1-Z2500	5118178			

TSF Wechselscheiben siehe Zubehör Seite 92 TSF discs, see accessories page 92

TSFV - Inch													
D1 [Inch]	A [Inch]	D [Inch]	L [Inch]	D2 [Inch]	D3 [Inch]	L1 [Inch]	N [Inch]	Bild Picture	Bezeichnung Designation	Ident No.			
0.125	2.48	0.50	4.33	0.39	0.50	0.79	0.20	2	TSFV0318-110-K1-Z1270	5118200			
0.125	2.28	0.75	4.33	0.39	0.75	0.98	0.20	1	TSFV0318-110-K1-Z1905	5118201			
0.187	2.48	0.50	4.33	0.43	0.50	0.98	0.20	2	TSFV0476-110-K1-Z1270	5118203			
0.187	2.28	0.75	4.33	0.43	0.75	0.98	0.20	1	TSFV0476-110-K1-Z1905	5118204			
0.250	2.48	0.50	4.33	0.47	0.50	1.42	0.39	3	TSFV0635-110-K1-Z1270	5118206			
0.250	2.28	0.75	4.33	0.47	0.75	1.42	0.39	1	TSFV0635-110-K1-Z1905	5118207			
0.375	2.28	0.75	4.33	0.63	0.75	1.65	0.39	2	TSFV0953-110-K1-Z1905	5118209			

TSFV													
D1 [Inch]	A [Inch]	D [Inch]	L [Inch]	D2 [Inch]	D3 [Inch]	L1 [Inch]	N [Inch]	Bild Picture	Bezeichnung Designation	Ident No.			
0.125	7.79	0.75	9.84	0.39	0.75	0.79	0.20	1	TSFV0318-250-K1-Z1905	5118202			
0.187	7.79	0.75	9.84	0.43	0.75	0.98	0.20	1	TSFV0476-250-K1-Z1905	5118205			
0.250	7.79	0.75	9.84	0.47	0.75	1.42	0.39	1	TSFV0635-250-K1-Z1905	5118208			
0.375	7.79	0.75	9.84	0.63	0.75	1.65	0.39	2	TSFV0953-250-K1-Z1905	5118210			
0.500	7.59	0.75	9.84	0.79	1.00	1.85	0.39	1	TSFV1270-250-K1-Z1905	5118211			
0.500	7.59	1.00	9.84	0.87	1.00	1.85	0.39	1	TSFV1270-250-K1-Z2540	5118212			
0.625	7.59	1.00	9.84	0.87	1.00	1.97	0.39	2	TSFV1588-250-K1-Z2540	5118213			

TSF Wechselscheiben siehe Zubehör Seite 92 TSF discs, see accessories page 92

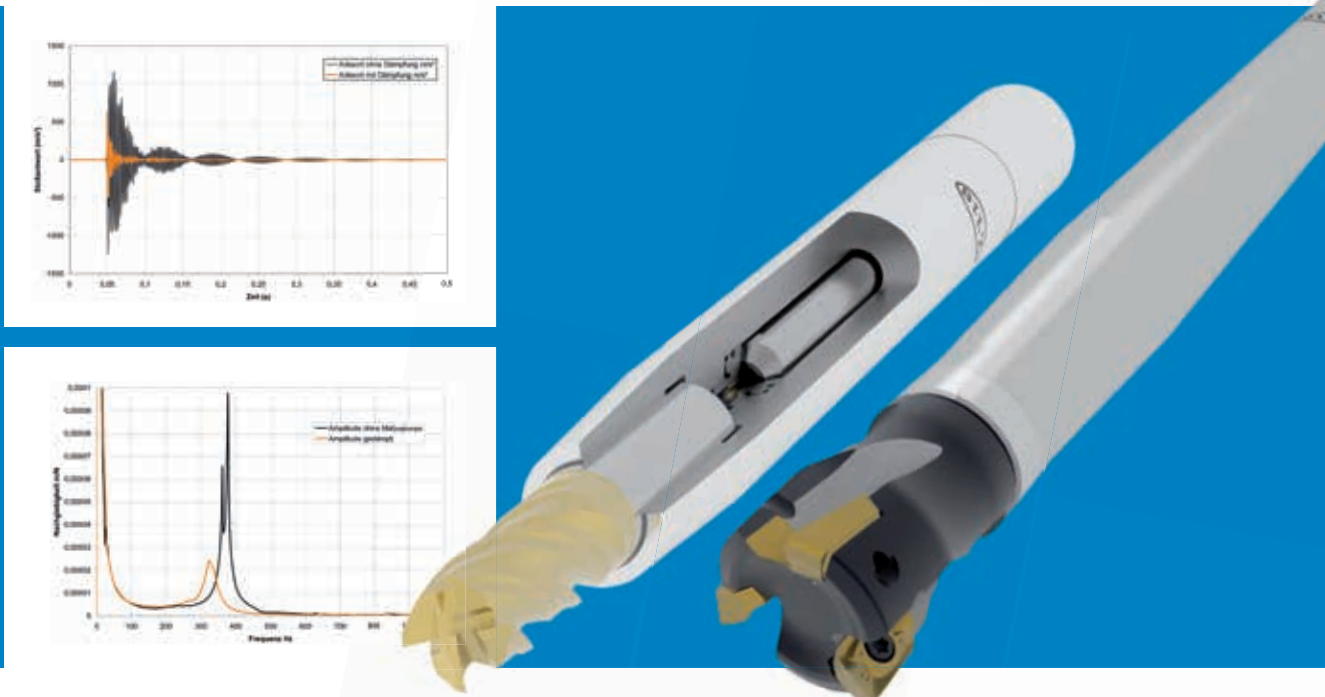

Wesentlich verbesserte Dämpfungseigenschaften mit Vidat
Significantly improved damping properties with Vidat

ThermoGrip® **VIDAT** steht für die **V**ibrations **DA**empfindende **T**echnologie aus dem Hause **Bilz**. Dabei werden durch integrierte Dämpfer auftretende Schwingungen, resultierend aus der ersten Biegung, wirkungsvoll gedämpft. VIDAT Verlängerungen erreichen dabei Dämpfungsraten von mindestens 4 dB im Vergleich zu normalen Verlängerungen. Bedingt durch die extrem starre Verbindung der Schrumpftechnik, neigen vor allem lange, schlanke Verlängerungen öfter zum Rattern und Vibrieren. VIDAT Verlängerungen reduzieren diesen Effekt und erweitern dadurch das Einsatzgebiet erheblich.

Durch den Einsatz der Bilz VIDAT Verlängerungen können Sie während der Bearbeitung

- die Vibrationen im Spannsystem verringern
- die Qualität der Oberfläche auf dem Werkstück verbessern
- die Standzeit der Werkzeugschneiden erhöhen

ThermoGrip® **VIDAT** stands for **V**ibrations **DA**mping **T**echnology from **Bilz**. Vibrations caused during the first extension deflection are effectively absorbed by integrated dampers. VIDAT extensions achieve damping rates of at least 4dB in comparison to normal extensions. The very rigid nature of the shrinking process means that long, slim extensions in particular have a tendency to chatter and vibrate. VIDAT extensions reduce this effect, thus considerably increasing the area of application.

By using Bilz VIDAT extensions you can

- reduce the vibrations in the clamping system
- improve the surface quality of the workpiece
- increase tool life

VIDAT

Schlanke Schrumpferlängerungen, schwingungsgedämpft
Slim Shrink Chuck Extensions with Vibration Damping

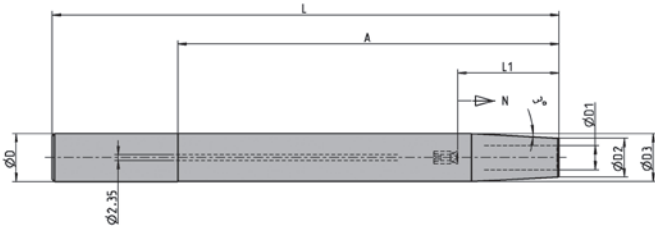

VIDAT Verlängerungen mit Schrumpfgeometrie VIDAT extensions with shrink geometry



D1	A	D	L	L1	D2	D3	N	max. Drehzahl in Kombination mit		Bezeichnung	Ident No.
								HSK63-HSK100/ ISO40-ISO50	HSK50/ ISO30		
6	158	20	210	36	12	19,8	5	10000 1/min	7000 1/min	LNE-T0600-210-K1-Z2000	5109763
8	158	20	210	36	14	19,8	5	10000 1/min	7000 1/min	LNE-T0600-210-K1-Z2000	5110224
10	158	20	210	42	16	19,8	5	10000 1/min	7000 1/min	LNE-T1000-210-K1-Z2000	5110226
12	158	20	210	47	18	19,8	5	10000 1/min	7000 1/min	LNE-T1200-210-K1-Z2000	5110227
10	242	25	300	42	16	24,8	5	8000 1/min	-	LNE-T1000-300-K1-Z2500	5110287
12	242	25	300	47	18	24,8	5	8000 1/min	-	LNE-T1200-300-K1-Z2500	5109988
14	242	25	300	47	20	24,8	5	8000 1/min	-	LNE-T1400-300-K1-Z2500	5109994
16	242	25	300	50	22	24,8	5	8000 1/min	-	LNE-T1600-300-K1-Z2500	5110303
12	238	32	300	47	18	31,8	5	8000 1/min	-	LNE-T1200-300-K1-Z3200	5110428
14	238	32	300	47	20	31,8	5	8000 1/min	-	LNE-T1400-300-K1-Z3200	5110429
16	238	32	300	50	22	31,8	5	8000 1/min	-	LNE-T1600-300-K1-Z3200	5110430
18	238	32	300	50	25	31,8	5	8000 1/min	-	LNE-T1800-300-K1-Z3200	5110433
20	238	32	300	52	27	31,8	5	8000 1/min	-	LNE-T2000-300-K1-Z3200	5110436

Innere Kühlmittelzufuhr bis max. 50 bar Internal coolant supply up to max. 50 bar



TSF Wechselscheiben siehe Zubehör Seite 92 TSF discs, see accessories page 92

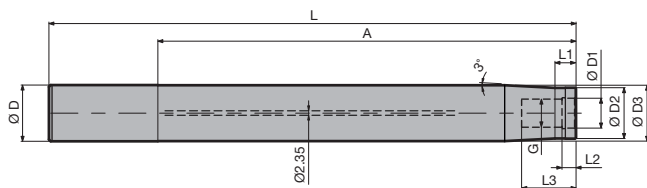

VIDAT Verlängerungen für Aufschraubfräser/Aufsteckfräser VIDAT extensions for shell milling cutters



G	A	D	L	L1	L2	L3	D1	D2	D3	max. Drehzahl in Kombination mit		Bezeichnung	Ident No.
										HSK63-HSK100/ ISO40-ISO50	HSK50/ ISO30		
M12 x 1,75	192	25	250	12	8,5	25	12,5	21	24,8	8000 1/min	-	LNE-MH12-250-K1-Z2500	5110692
M12 x 1,75	242	25	300	12	8,5	25	12,5	21	24,8	8000 1/min	-	LNE-MH12-300-K1-Z2500	5110690
M16 x 2	188	32	250	12	9	31	17	29	31,8	8000 1/min	-	LNE-MH16-250-K1-Z3200	5110698
M16 x 2	238	32	300	12	9	31	17	29	31,8	8000 1/min	-	LNE-MH16-300-K1-Z3200	5110696

Innere Kühlmittelzufuhr bis max. 50 bar Internal coolant supply up to max. 50 bar



TSF Wechselscheiben siehe Zubehör Seite 92 TSF discs, see accessories page 92

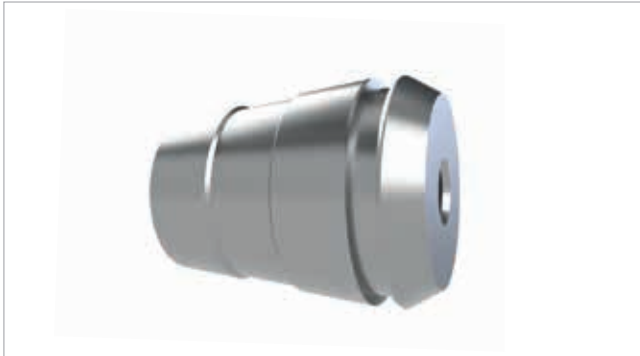

Einsatzbereich: Spannzangenfutter, angetriebene Werkzeugaufnahmen, Direktspannung in Maschinenspindel

Perfekter Halt

Ist das Werkzeug nicht sicher eingespannt, wirken durch die Rotation bei der Bearbeitung starke Kräfte auf Werkzeug und Futter. Das Werkzeug beginnt zu eiern. Die Folge: wachsender Verschleiß durch hohe Belastung von Werkzeug und Futter bei wesentlich schlechteren Bearbeitungsergebnissen (Oberflächengüte!). Mit TER wird der Belastungseffekt durch Unwucht des Werkzeugs nahezu eliminiert. Äußerst exakt in das Zentrum der Spannbohrung eingespannt, läuft das Werkzeug optimal rund und bildet in eingeschrumpftem Zustand eine kurze und stabile Einheit mit der TER-Spannzange. Die exakte Führung des Werkzeugs ermöglicht mehr Präzision auch bei hohen Bearbeitungsgeschwindigkeiten und minimiert Belastungen und Verschleiß durch axiale Kräfte erheblich.

TER nutzen heißt von den zentralen Vorteilen der Schrumpfsparntechnik profitieren,

- Rundlaufgenauigkeit < 3 µm
- maximale Haltekräfte
- Steifigkeit
- verschleißarme Monoblockeigenschaften ohne die vorhandenen Spannzangenfutter oder Spindeln durch ein neues Spannkonzep ersetzt zu müssen.

Höhere Produktionsgeschwindigkeit

Der große Leistungsvorteil der TER liegt in der Möglichkeit, mit deutlich höheren Schnittdaten zu arbeiten. Die TER Schrumpfsparnzange ist auf allen gängigen ThermoGrip® Geräten vom Typ ISG schrumpfbar.

Areas of application: collet chucks, driven tool holders, direct clamping in the machine spindle

Perfect Fit

If the tool is not clamped securely, high forces are exerted on the tool and chuck through rotation. The tool will begin to wobble. The result: a higher load, therefore increased wear on the chuck and tool, leading to impaired quality of the manufacturing result. Using TER means that the load on the tool due to imbalance is practically eliminated. The tool is clamped precisely in the centre of the clamping bore, meaning that it runs true and when shrunk in, it forms a stable unit with the TER collet. The short and rigid clamping enables high precision at higher cutting speeds and reduces the wear on the cutting tool dramatically.

Using TER means profiting from the main advantages of collet shrinking,

- Run-out < 3 µm
- maximum holding forces
- rigidity
- low-wear monoblock properties without the need to replace existing collet chucks or spindles.

Much higher cutting speeds

The biggest advantage of TER is the potential of machining with much higher cutting speeds. The TER shrink fit collet can be heated on all ThermoGrip® induction units.

Höchste Rundlauf- und Wiederholgenauigkeit
 Highest possible run-out and repeatability accuracy

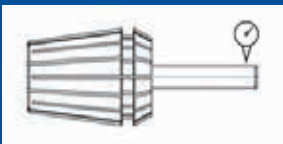

> 10 µm

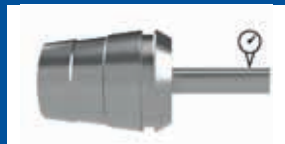

< 3 µm

Im eingeschrumpften Zustand bilden Schneidwerkzeug und Schrumpfsparneinsatz eine Einheit (Monoblock)

Das Ergebnis:

Ein sehr hohes, übertragbares Drehmoment, beste Rundlaufeigenschaften und höchste Stabilität

When shrunk in, cutting tool and shrink fit collet form a unit (monoblock)

Result:

A very high transmittable torque, best possible run-out properties and highest possible stability



Standzeiterhöhung bei Zerspanungswerkzeugen bis 300%

Durch das exakte Einspannen des Schneidwerkzeugs mit der TER - Schrumpfsparnzange tauchen alle Schneiden gleichzeitig in das Werkstück ein – kein „Schlagen“ der Schneide.

Das Ergebnis:

Verbesserte Oberflächengüte & hervorragende Präzision

Increase of tool life for cutting tools up to 300%

Due to the precise clamping of the tool with the TER shrink collets, all cutters enter the workpiece simultaneously, avoiding "hitting" the cutting edge.

Result:

Better surface finishes & improved accuracy

Produktionskosten senken durch Höchstleistung – TER macht's möglich!
Using high efficiency to reduce production costs – TER makes it possible!

Mehr produzieren in kürzerer Zeit	Increase productivity in a short period of time
Arbeiten mit Hochgeschwindigkeit <ul style="list-style-type: none"> hohes übertragbares Drehmoment stabile Einspannung maximale Haltekräfte ultrapräziser, schneller Werkzeugwechsel (< 30s) 	High-speed machining <ul style="list-style-type: none"> High transmittable torque Stable clamping Maximum holding forces Ultra-precise, quick tool changes (< 30s)
Länger produzieren durch weniger Verschleiß	Longer machining due to less wear
Standzeiterhöhungen bis zu 300 % <ul style="list-style-type: none"> sehr hohe Stabilität des Systems minimale Belastungen durch axiale Kräfte weniger Ausbruch durch sauberen Rundlauf keine Verschmutzung (dichtes Monoblock-System) 	Increase of tool life for cutting tools up to 300 % <ul style="list-style-type: none"> High stability of the system Minimum load from axial forces Precise clamping means less damage Resistant to dirt (sealed monoblock system)
Hochwertig produzieren für beste Ergebnisse	High quality machining for top results
Hochpräzise und prozesssicher <ul style="list-style-type: none"> hervorragende Rundlaufeigenschaften (< 3 µm) extreme Wiederholgenauigkeit durch exakte Spannung 	High precision and process-secure <ul style="list-style-type: none"> Excellent run-out properties (< 3 µm) High repeatability due to precise clamping
Effektiver produzieren ohne Fertigungsumstellung	Improve manufacturing without changing production processes
Und Sie müssen nicht einmal umrüsten... <ul style="list-style-type: none"> vorhandene Spannzangenfutter weiter verwendbar ein universeller Werkzeughalter für alle Größen Verschleißteil Dichtscheibe wird nicht mehr benötigt 	No need to retool ... <ul style="list-style-type: none"> Existing collet chucks can still be used Universal toolholder for all sizes Sealing disc is no longer required – cost and logistics saving

Success Story

Aufgabe Situation	Lösung Solution	Kundennutzen Customer benefit
Wirbelsäulen Stützelement Spinal Support Element Maschine: Machine: INDEX G 200 Losgröße: Parts: 1500 Material: Material: TiAl6V4 Wettbewerb: Competition: Spannzange Collets DIN 6499-25 Ø 6mm (Schlichten) (Finishing) Ø 10mm (Schruppen) (Roughing) Schnittdaten: Cutting data: Schlichten: Finishing: Vc = 75,36 fz = 0,05 Schruppen: Roughing: Vc = 50,24 fz = 0,08 Schlichten: Finishing: Bearbeitungszeit: Cutting time: 20 s Standmenge: Tool life: 500 Stück pieces Schruppen: Roughing: Bearbeitungszeit: Cutting time: 75 s Standmenge: Tool life: 500 Stück pieces	 Werkzeug: Tool: TER0600/25 (Schlichten) (Finishing) TER1000/25 (Schruppen) (Roughing) Schnittdaten: Cutting data: Schlichten: Finishing: Vc = 84,78 fz = 0,06 Schruppen: Roughing: Vc = 50,24 fz = 0,2 Schlichten: Finishing: Bearbeitungszeit: Cutting time: 17 s Standmenge: Tool life: 1500 Stück pieces Schruppen: Roughing: Bearbeitungszeit: Cutting time: 30 s Standmenge: Tool life: 1500 Stück pieces	Reduzierung der Bearbeitungszeit: Reduction of the cutting time: 48 s 7,82 min → 7,02 min → 11,39 % Erhöhung Standmenge: Increase tool life: 300 % Kostenrechnung: Cost calculation: Reduzierung der Bearbeitungszeit: Reduction of the cutting time: 48s / Werkstück work piece Losgröße: Parts: 1500 Stück pieces Maschinenstundensatz: Machine cost: 3 €/min Kostenreduzierung: Cost reduction: 

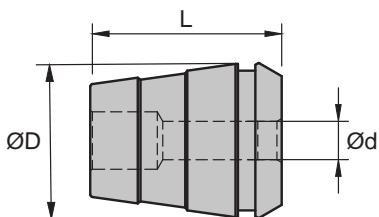

TER ↗ ≤ 3µm				
D1 [mm]	DA [mm]	L [mm]	Bezeichnung Designation	Ident No.
TER.../11 ER11/4008E				
3	11	18	TER0300/11	5076671
4			TER0400/11	5076673
6			TER0600/11	5076674
TER.../16 ER16/426E				
3	16	27,5	TER0300/16	5004694
4			TER0400/16	5004696
6			TER0600/16	5004697
8			TER0800/16	5004698
TER.../20 ER20/428E				
6	20	31,5	TER0600/20	5004699
8			TER0800/20	5004700
10			TER1000/20	5004701
TER.../25 ER25/430E				
3	25	34	TER0300/25	5004702
4			TER0400/25	5004703
6			TER0600/25	5004705
8			TER0800/25	5004706
10			TER1000/25	5004707
12			TER1200/25	5004708
14			TER1400/25	5004709
16			TER1600/25	5004710
TER.../32 ER32/470E				
6	32	40	TER0600/32	5004711
8			TER0800/32	5004712
10			TER1000/32	5004713
12			TER1200/32	5004714
14			TER1400/32	5004715
16			TER1600/32	5004717
18			TER1800/32	5004718
20			TER2000/32	5004719

Benötigtes Gerätzubehör siehe ThermoGrip® Schrumpfgeräte Katalog Required Accessories see Thermogrip® Shrink Units Catalog

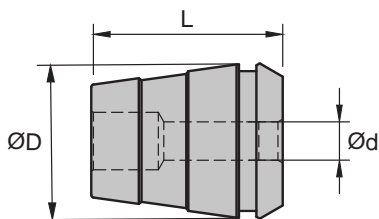

TER – Inch ↗ ≤ 3µm				
D1 [Inch]	DA [Inch]	L [Inch]	Bezeichnung Designation	Ident No.
TER.../16 ER16/426E				
0.125	0,67	1,22	TER0318/16	5059311
0.156			TER0397/16	5089047
0.187			TER0476/16	5068405
0.250			TER0635/16	5059313
0.312			TER0794/16	5089048
TER.../20 ER20/428E				
0.125	0,83	1,22	TER0318/20	5068413
0.156			TER0397/20	5089049
0.250			TER0635/20	5059315
0.312			TER0794/20	5089050
0.375			TER0953/20	5059316
TER.../25 ER25/430E				
0.125	1,02	1,38	TER0318/25	5068416
0.187			TER0476/25	5068417
0.250			TER0635/25	5068419
0.312			TER0794/25	5089052
0.375			TER0953/25	5068420
0.437			TER1111/25	5089055
0.500			TER1270/25	5060472
0.625			TER1588/25	5068421
TER.../32 ER32/470E				
0.250	1.30	1.57	TER0635/32	5059317
0.375			TER0953/32	5059318
0.500			TER1270/32	5059319
0.625			TER1588/32	5060473
0.750			TER1905/32	5068422

Benötigtes Gerätezubehör siehe ThermoGrip® Schrumpferäte Katalog Required Accessories see Thermogrip® Shrink Units Catalog

TERV
Schrumpfeinsatz
Shrink Fit Adaptor

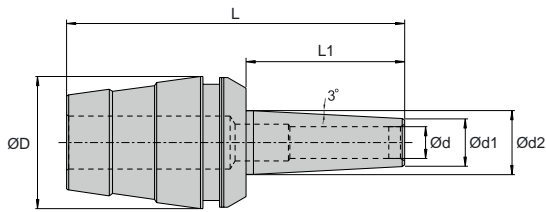

ØD (mm)	Ød (mm)	Ød1 (mm)	Ød2 (mm)	L (mm)	L1 (mm)	Bezeichnung Designation	Ident No.
11	3	6	7.0	28.0	10	TERV0300-10-EX11	5170806
11	3	6	8.0	38.0	20	TERV0300-20-EX11	5170807
11	4	7	8.0	28.0	10	TERV0400-10-EX11	5170808
16	3	6	7.0	37.5	10	TERV0300-10-EX16	5170809
16	3	6	8.5	52.5	25	TERV0300-25-EX16	5170810
16	4	7	8.0	37.5	10	TERV0400-10-EX16	5170811
16	4	7	9.0	52.5	25	TERV0400-25-EX16	5170812
16	5	8	9.0	37.5	10	TERV0500-10-EX16	5170813
16	5	8	10.5	52.5	25	TERV0500-25-EX16	5170814
16	6	9	10.0	37.5	10	TERV0600-10-EX16	5168473
16	6	9	10.5	47.5	20	TERV0600-20-EX16	5168474
16	6	9	10.5	57.5	30	TERV0600-30-EX16	5168475
20	3	6	7.0	41.5	10	TERV0300-10-EX20	5170815
20	3	6	8.5	56.5	25	TERV0300-25-EX20	5170816
20	4	7	8.0	41.5	10	TERV0400-10-EX20	5170817
20	4	7	9.5	56.5	25	TERV0400-25-EX20	5170818
20	5	8	9.0	41.5	10	TERV0500-10-EX20	5170819
20	6	9	10.0	41.5	10	TERV0600-10-EX20	5168481
20	6	9	11.0	51.5	20	TERV0600-20-EX20	5168482
20	6	9	12.0	61.5	30	TERV0600-30-EX20	5168483
20	8	11	13.0	51.5	20	TERV0800-20-EX20	5168484
20	8	11	14.0	61.5	30	TERV0800-30-EX20	5168485
25	3	6	7.0	44.0	10	TERV0300-10-EX25	5170820
25	3	6	8.0	54.0	20	TERV0300-20-EX25	5170821
25	4	6	8.0	44.0	10	TERV0400-10-EX25	5170822
25	4	7	9.5	59.0	25	TERV0400-25-EX25	5170823
25	5	8	9.0	44.0	10	TERV0500-10-EX25	5170824
25	6	9	10.0	44.0	10	TERV0600-10-EX25	5168491
25	6	9	11.0	54.0	20	TERV0600-20-EX25	5168492
25	6	9	12.0	64.0	30	TERV0600-30-EX25	5168493
25	8	11	13.0	54.0	20	TERV0800-20-EX25	5168494
25	8	11	14.0	64.0	30	TERV0800-30-EX25	5168495
25	10	13	15.0	54.0	20	TERV1000-20-EX25	5168496
25	12	15	17.0	54.0	20	TERV1200-20-EX25	5168497
32	3	6	8.0	60.0	20	TERV0300-20-EX32	5170825
32	4	7	9.0	60.0	20	TERV0400-20-EX32	5170826
32	6	9	11.0	60.0	20	TERV0600-20-EX32	5168501
32	6	9	12.0	70.0	30	TERV0600-30-EX32	5168502
32	8	11	13.0	60.0	20	TERV0800-20-EX32	5168503
32	8	11	14.0	70.0	30	TERV0800-30-EX32	5168504
32	10	13	15.0	60.0	20	TERV1000-20-EX32	5168505
32	12	15	17.0	60.0	20	TERV1200-20-EX32	5168506
32	12	15	18.0	70.0	30	TERV1200-30-EX32	5168507
32	14	17	19.0	60.0	20	TERV1400-20-EX32	5168508
32	16	19	21.0	60.0	20	TERV1600-20-EX32	5168509

Benötigtes Gerätezubehör siehe ThermoGrip® Schrumpferäte Katalog Required Accessories see Thermogrip® Shrink Units Catalog

TERV

Schrumpfeinsatz
Shrink Fit Adaptor

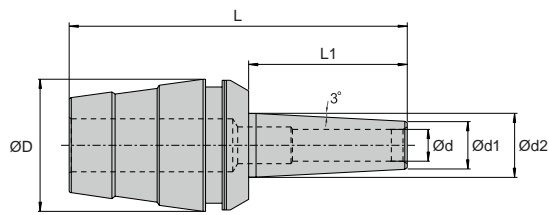



ØD (mm)	Ød (inch)	Ød1 (mm)	Ød2 (mm)	L (mm)	L1 (mm)	Bezeichnung Designation	Ident No.
11	1/8"	6	7.0	28.0	10	TERV0318-10-EX11	5168510
11	1/8"	6	8.0	38.0	20	TERV0318-20-EX11	5168511
11	3/16"	7	8.0	28.0	10	TERV0476-10-EX11	5168512
16	1/8"	6	7.0	37.5	10	TERV0318-10-EX16	5168513
16	1/8"	6	8.5	52.5	25	TERV0318-25-EX16	5168514
16	3/16"	8	9.0	37.5	10	TERV0476-10-EX16	5168515
16	3/16"	8	10.5	52.5	25	TERV0476-25-EX16	5168516
16	1/4"	9	10.0	37.5	10	TERV0635-10-EX16	5168518
16	1/4"	9	10.5	47.5	20	TERV0635-20-EX16	5168519
16	1/4"	9	10.5	57.5	30	TERV0635-30-EX16	5168520
20	1/8"	6	7.0	41.5	10	TERV0318-10-EX20	5168521
20	1/8"	6	8.5	56.5	25	TERV0318-25-EX20	5168522
20	3/16"	8	9.0	41.5	10	TERV0476-10-EX20	5168523
20	3/16"	8	10.5	56.5	25	TERV0476-25-EX20	5168524
20	1/4"	9	10.0	41.5	10	TERV0635-10-EX20	5168525
20	1/4"	9	11.0	51.5	20	TERV0635-20-EX20	5168526
20	1/4"	9	12.0	61.5	30	TERV0635-30-EX20	5168527
20	5/16"	11	13.0	51.5	20	TERV0794-20-EX20	5168530
20	5/16"	11	14.0	61.5	30	TERV0794-30-EX20	5168531
25	1/8"	6	7.0	44.0	10	TERV0318-10-EX25	5168532
25	1/8"	6	8.0	54.0	20	TERV0318-20-EX25	5168533
25	3/16"	8	9.0	44.0	10	TERV0476-10-EX25	5168534
25	3/16"	8	10.5	59.0	25	TERV0476-25-EX25	5168535
25	1/4"	9	10.0	44.0	10	TERV0635-10-EX25	5168536
25	1/4"	9	11.0	54.0	20	TERV0635-20-EX25	5168537
25	1/4"	9	12.0	64.0	30	TERV0635-30-EX25	5168538
25	5/16"	11	13.0	54.0	20	TERV0794-20-EX25	5168539
25	5/16"	11	14.0	64.0	30	TERV0794-30-EX25	5168540
25	3/8"	13	14.0	44.0	10	TERV0953-10-EX25	5168541
25	1/2"	16	17.0	44.0	10	TERV1270-10-EX25	5168542
32	1/8"	6	8.0	60.0	20	TERV0318-20-EX32	5168543
32	3/16"	8	10.0	60.0	20	TERV0476-20-EX32	5168544
32	1/4"	9	11.0	60.0	20	TERV0635-20-EX32	5168545
32	1/4"	9	12.0	70.0	30	TERV0635-30-EX32	5168546
32	5/16"	11	13.0	60.0	20	TERV0794-20-EX32	5168547
32	5/16"	11	14.0	70.0	30	TERV0794-30-EX32	5168548
32	3/8"	13	15.0	60.0	20	TERV0953-20-EX32	5168549
32	1/2"	16	18.0	60.0	20	TERV1270-20-EX32	5168550
32	1/2"	16	19.0	70.0	30	TERV1270-30-EX32	5168551
32	5/8"	19	21.0	60.0	20	TERV1588-20-EX32	5168552

Benötigtes Gerätezubehör siehe ThermoGrip® Schrumpfgeräte Katalog Required Accessories see Thermogrip® Shrink Units Catalog

Neben höchstem Qualitätsstandard in der Fertigung legen wir größten Wert auf intensive Anwendungsberatung, Kundenbetreuung und Lösungskompetenz. Werkzeuge werden vielfach nach Anforderungen unserer Kunden individuell konzipiert. While providing the highest quality standards in production, we strongly emphasize application support, customer relations, and competency for solutions. Separate from our standard range are individually designed chucks for the needs of our customers. Sustainable solutions from Bilz offer unequalled benefits worldwide

EINZIGARTIGE NACHHALTIGKEIT UNIQUE SUSTAINABILITY

 <p>Mensch</p> <p>Unsere Lösungen bieten Gesundheitsschutz und Arbeitssicherheit durch ein sauberes Arbeitsumfeld und minimieren das Risiko von Hauterkrankungen.</p>	 <p>Ökonomie</p> <p>Unsere Lösungen stehen für reduzierte Beschaffungs- und Wartungskosten, keine Entsorgungskosten und höhere Standzeiten.</p>	 <p>Umwelt</p> <p>Unsere Lösungen senken Kosten um bis zu 19%, reduzieren den Verbrauch enorm und die Sondermüllentsorgung entfällt.</p>
<p>Personnel safety</p> <p>Our solutions deliver employee protection and safety at work by maintaining a hazard-free working environment and minimizing skin problems.</p>	<p>Economy</p> <p>Our solutions stand for reduced sourcing and maintenance cost as well as reduced disposal issues and increased tool life.</p>	<p>Environment</p> <p>Our solutions reduce costs up to 19%, reduce the usage dramatically, and the expensive disposal of coolant is not needed.</p>



MMS MQL

Wegen der sehr geringen Schmierstoffmenge ist es bei Minimalmengenschmierung (MMS) enorm wichtig, den Schmierstoff zielgenau und bedarfsgerecht dosiert an der Zerspanstelle aufzubringen. Due to the extremely low volume of lubricant with Minimal Quality Lubricant (MQL) technology, it's very important to deliver the lubricant precisely on target and with the exact quantity needed directly to the point of the tool.

Die neue MMS-fähige Spannmittelgeneration von Bilz löst diese beiden Herausforderungen an das Spannmittel zu 100%:

- **Optimale Dichtigkeit**
für einen verlustfreien Aerosolstrom ohne Versackungen oder Austritt von Schmiermittel aus dem Spannfutter in Form von feinem Tröpfchennebel
- **Optimized sealed design**
provides loss-free lubricant delivery.
The design of the toolholder guarantees that all lubricant is applied immediately, no lubricant loss due to flow problems.
- **Sofortige Schmierstoffzufuhr**
für einen verzögerungsfreien Durchfluss des Aerosols ohne Druckabfall bis an die Werkzeugspitze
- **Immediate lubricant**
delivery for delay-free flow of the aerosol without any loss in pressure up to the tool tip

Ihr Nutzen: Sie arbeiten mit optimaler Dichtigkeit sowie mit Schmierstoff von der ersten Sekunde an – verlustfrei!
Your advantage: with optimal leak prevention, we deliver lubricant from the very first second – loss-free.

*Hinweis Wuchtgüte siehe Seite 14 Balancing Information, page 14

1 1-Kanal-System lizenziert nach Horkos Corp.
1-Channel system licence of Horkos Corp.

2 2-Kanal-System
2-Channel System

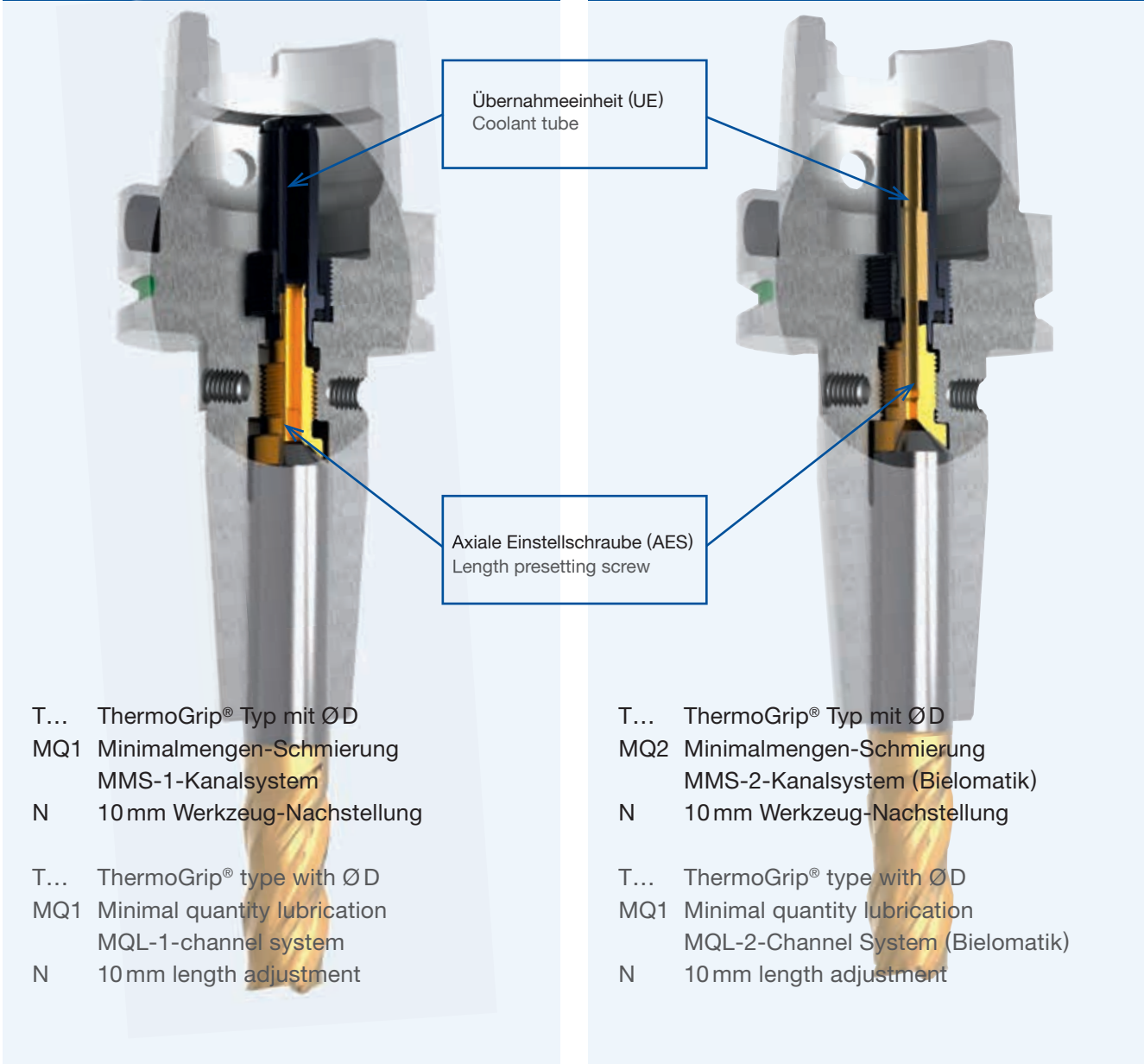

- T... ThermoGrip® Typ mit ØD
- MQ1 Minimalmengen-Schmierung
MMS-1-Kanalsystem
- N 10mm Werkzeug-Nachstellung

- T... ThermoGrip® type with ØD
- MQ1 Minimal quantity lubrication
MQL-1-channel system
- N 10mm length adjustment

- T... ThermoGrip® Typ mit ØD
- MQ2 Minimalmengen-Schmierung
MMS-2-Kanalsystem (Bielomatik)
- N 10mm Werkzeug-Nachstellung

- T... ThermoGrip® type with ØD
- MQ1 Minimal quantity lubrication
MQL-2-Channel System (Bielomatik)
- N 10mm length adjustment

Checkliste MMS unter www.bilz.de oder direkt per QR Code:
Check list for MQL at www.bilz.de or direct via QR Code:

DE



EN





MMS 1-Kanal-System Schrumpffutter
 MQL 1-Channel-System Shrink Chucks

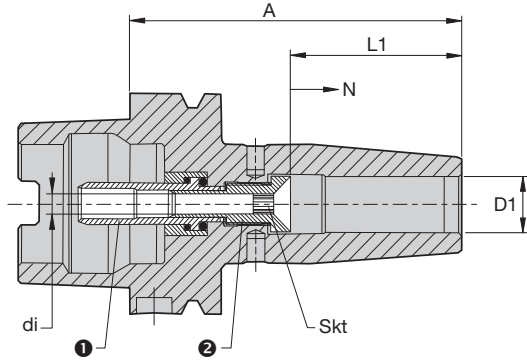

Schrumpffutter Shrink Chucks					Übernahmeeinheit Supply unit ①			Axiale Einstellschraube Setting screw ②				
D1 [mm]	A [mm]	L1 [mm]	Bezeichnung Designation	Ident No.	di	UE-Type BILZ	Ident No.	Skt	AES-Type BILZ	Ident No.		
6	80	36	T0600-MQ1-80/HSK-A63/0001	5056416	4,6	UE6-HSK63	5050204	4	T0600-3B-63	5056199		
8	80	36	T0800-MQ1-80/HSK-A63/0001	5050219					T0800-3B-63	5050206		
10	85	40	T1000-MQ1-85/HSK-A63/0001	5050220					T1000-3B-63	5049429		
12	90	45	T1200-MQ1-90/HSK-A63/0001	5058016				5,8		5	T1200-3B-63	5056207
14	90	45	T1400-MQ1-90/HSK-A63/0001	5050221							T1400-3B-63	5050207
16	95	48	T1600-MQ1-95/HSK-A63/0001	5058017							T1600-3B-63	5056213
18	95	48	T1800-MQ1-95/HSK-A63/0001	5058018							T1800-3B-63	5056219
20	100	50	T2000-MQ1-100/HSK-A63/0001	5058019							T2000-3B-63	5049430
25	115	56	T2500-MQ1-115/HSK-A63/0001	5058020							T2500-3B-63	5056216
32	120	60	T3200-MQ1-120/HSK-A63/0001	5058021							T3200-3B-63	5057000
6	120	36	T0600-MQ1-120/HSK-A63/0001	5074641	2,3	UE6-HSK63	5050204	2	T0600-3B-32	5056966		
8		36	T0800-MQ1-120/HSK-A63/0001	5051301	3,45			3	T0800-3B-40	5051305		
10		40	T1000-MQ1-120/HSK-A63/0001	5076833	4,6			4	T1000-3B-50	5050209		
12		45	T1200-MQ1-120/HSK-A63/0001	5076835	5,8			5	T1200-3B-63	5056207		
14		45	T1400-MQ1-120/HSK-A63/0001	5076836				T1400-3B-63	5050207			
16		48	T1600-MQ1-120/HSK-A63/0001	5076837				T1600-3B-63	5056213			
18		48	T1800-MQ1-120/HSK-A63/0001	5076838				T1800-3B-63	5056219			
20		50	T2000-MQ1-120/HSK-A63/0001	5076840				T2000-3B-63	5049430			
6	160	36	T0600-MQ1-160/HSK-A63/0001	5054945	2,3	UE6-HSK63	5050204	2	T0600-3B-32	5056966		
8		36	T0800-MQ1-160/HSK-A63/0001	5054946	3,45			3	T0800-3B-40	5051305		
10		40	T1000-MQ1-160/HSK-A63/0001	5050222	4,6			4	T1000-3B-50	5050209		
12		45	T1200-MQ1-160/HSK-A63/0001	5054947	5,8			5	T1200-3B-63	5056207		
14		45	T1400-MQ1-160/HSK-A63/0001	5054948				T1400-3B-63	5050207			
16		48	T1600-MQ1-160/HSK-A63/0001	5054949				T1600-3B-63	5056213			
18		48	T1800-MQ1-160/HSK-A63/0001	5054950				T1800-3B-63	5056219			
20		50	T2000-MQ1-160/HSK-A63/0001	5054951				T2000-3B-63	5049430			
25		56	T2500-MQ1-160/HSK-A63/0001	5054952				T2500-3B-63	5056216			
32		60	T3200-MQ1-160/HSK-A63/0001	5054953				T3200-3B-63	5057000			

Im Lieferumfang enthalten: Übernahmeeinheit & Einstellschraube
 Delivery package: supply unit & setting screw



MMS 2-Kanal-System **Schrumpffutter**
 MQL 2-Channel-System **Shrink Chucks**

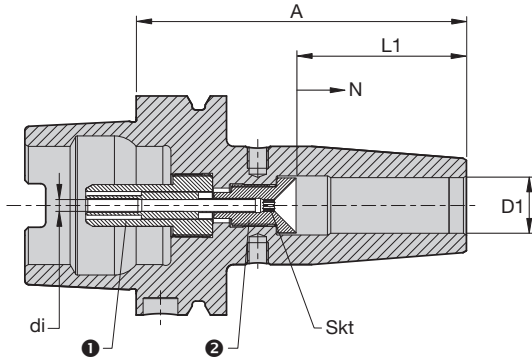

Schrumpffutter Shrink Chucks				Übernahmeeinheit Supply unit				Axiale Einstellschraube Setting screw			
D1 [mm]	A [mm]	L1 [mm]	Bezeichnung Designation	Ident No.	di	UE-Type BILZ	Ident No.	Skt	AES-Type BILZ	Ident No.	
6	80	36	T0600-MQ2-80/HSK-A 63/0001	5043587	1,6	UE5-HSK63-50/1	5037176	1,5	T0600-2B-63/1	5037179	
			T0600-MQ2-80/HSK-A 63/0002	5043590	2,3	UE5-HSK63-50/2	5037289	2,0	T0600-2B-63/2	5041227	
8	80	36	T0800-MQ2-80/HSK-A 63/0001	5043818	1,6	UE5-HSK63-50/1	5037176	1,5	T0800-2B-63/1	5037263	
			T0800-MQ2-80/HSK-A 63/0002	5043819	2,3	UE5-HSK63-50/2	5037289	2,0	T0800-2B-63/2	5041243	
10	85	40	T1000-MQ2-85/HSK-A 63/0001	5043820	1,6	UE5-HSK63-50/1	5037176	1,5	T1000-2B-63/1	5041380	
			T1000-MQ2-85/HSK-A 63/0002	5043821	2,3	UE5-HSK63-50/2	5037289	2,0	T1000-2B-63/2	5037285	
12	90	45	T1200-MQ2-90/HSK-A 63/0001	5043823	1,6	UE5-HSK63-49/1	5043830	1,5	T1200-2B-63/1	5041379	
			T1200-MQ2-90/HSK-A 63/0002	5043824	2,3	UE5-HSK63-49/2	5039864	2,0	T1200-2B-63/2	5037301	
			T1200-MQ2-90/HSK-A 63/0003	5043825	3,4	UE5-HSK63-49/3	5038801	3,0	T1200-2B-63/3	5041250	
14	90	45	T1400-MQ2-90/HSK-A 63/0001	5043826	1,6	UE5-HSK63-49/1	5043830	1,5	T1400-2B-63/1	5041377	
			T1400-MQ2-90/HSK-A 63/0002	5043827	2,3	UE5-HSK63-49/2	5039864	2,0	T1400-2B-63/2	5041378	
			T1400-MQ2-90/HSK-A 63/0003	5043828	3,4	UE5-HSK63-49/3	5038801	3,0	T1400-2B-63/3	5037323	
16	95	48	T1600-MQ2-95/HSK-A 63/0001	5043934	1,6	UE5-HSK63-49/1	5043830	1,5	T1600-2B-63/1	5041376	
			T1600-MQ2-95/HSK-A 63/0002	5043935	2,3	UE5-HSK63-49/2	5039864	2,0	T1600-2B-63/2	5037356	
			T1600-MQ2-95/HSK-A 63/0003	5043936	3,4	UE5-HSK63-49/3	5038801	3,0	T1600-2B-63/3	5037325	
18	95	48	T1800-MQ2-95/HSK-A 63/0001	5043937	1,6	UE5-HSK63-49/1	5043830	1,5	T1800-2B-63/1	5041375	
			T1800-MQ2-95/HSK-A 63/0002	5043939	2,3	UE5-HSK63-49/2	5039864	2,0	T1800-2B-63/2	5041236	
			T1800-MQ2-95/HSK-A 63/0003	5043940	3,4	UE5-HSK63-49/3	5038801	3,0	T1800-2B-63/3	5037329	
20	100	50	T2000-MQ2-100/HSK-A 63/0002	5043953	2,3	UE5-HSK63-49/2	5039864	2,0	T2000-2B-63/2	5041382	
			T2000-MQ2-100/HSK-A 63/0003	5043954	3,4	UE5-HSK63-49/3	5038801	3,0	T2000-2B-63/3	5041400	
			T2000-MQ2-100/HSK-A 63/0004	5043955	4,6	UE5-HSK63-50/4	5037339	4,0	T2000-2B-63/4	5037338	
25	115	56	T2500-MQ2-115/HSK-A 63/0002	5043956	2,3	UE5-HSK63-54/2	5043968	2,0	T2500-2B-63/2	5041384	
			T2500-MQ2-115/HSK-A 63/0003	5043957	3,4	UE5-HSK63-54/3	5043969	3,0	T2500-2B-63/3	5041385	
			T2500-MQ2-115/HSK-A 63/0004	5043958	4,6	UE5-HSK63-54/4	5039132	4,0	T2500-2B-63/4	5037344	
32	120	60	T3200-MQ2-120/HSK-A 63/0002	5043965	2,3	UE5-HSK63-54/2	5043968	2,0	T3200-2B-63/2	5041386	
			T3200-MQ2-120/HSK-A 63/0003	5043966	3,4	UE5-HSK63-54/3	5043969	3,0	T3200-2B-63/3	5041387	
			T3200-MQ2-120/HSK-A 63/0004	5043967	4,6	UE5-HSK63-54/4	5039132	4,0	T3200-2B-63/4	5041388	

Im Lieferumfang enthalten: Übernahmeeinheit & Einstellschraube
 Delivery package: supply unit & setting screw

MMS 2-Kanal-System MQL 2-channel system	
Rohrinnen Ø Tube bore Ø	Kreisfläche Circle area
di, mm	Ae, mm ²
1,6	2,01
2,3	4,15
3,4	9,08
4,6	16,62



MMS 2-Kanal-System **Schrumpffutter**
 MQL 2-Channel-System **Shrink Chucks**

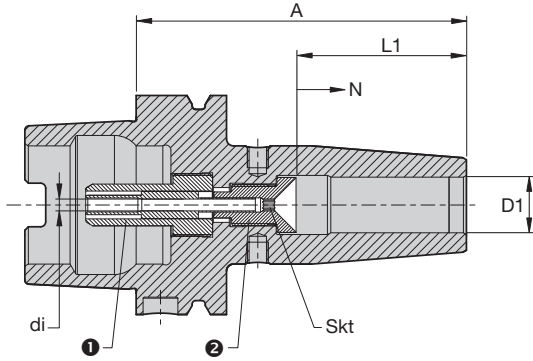

Schrumpffutter Shrink Chucks				Übernahmeeinheit Supply unit ①				Axiale Einstellschraube Setting screw ②		
D1 [mm]	A [mm]	L1 [mm]	Bezeichnung Designation	Ident No.	di	UE-Type BILZ	Ident No.	Skt	AES-Type BILZ	Ident No.
6	120	36	T0600-MQ2-120/HSK-A 63/0001	-	1,6	UE5-HSK63-90/1	5037264	1,5	T0600-2B-32/1	5037207
			T0600-MQ2-120/HSK-A 63/0002	-	2,3	UE5-HSK63-90/2	5039009	2,0	T0600-2B-32/2	5041398
8	120	36	T0800-MQ2-120/HSK-A 63/0001	5072972	1,6	UE5-HSK63-90/1	5037264	1,5	T0800-2B-40/1	5037266
			T0800-MQ2-120/HSK-A 63/0002	-	2,3	UE5-HSK63-90/2	5039009	2,0	T0800-2B-40/2	5038976
10	120	40	T1000-MQ2-120/HSK-A 63/0001	-	1,6	UE5-HSK63-85/1	5044847	1,5	T1000-2B-50/1	5041389
			T1000-MQ2-120/HSK-A 63/0002	-	2,3	UE5-HSK63-85/2	5037300	2,0	T1000-2B-50/2	5037290
12	120	45	T1200-MQ2-120/HSK-A 63/0001	-	1,6	UE5-HSK63-79/1	5045174	1,5	T1200-2B-63/1	5041379
			T1200-MQ2-120/HSK-A 63/0002	5072397	2,3	UE5-HSK63-79/2	5039011	2,0	T1200-2B-63/2	5037301
			T1200-MQ2-120/HSK-A 63/0003	-	3,4	UE5-HSK63-79/3	5037303	3,0	T1200-2B-63/3	5041250
14	120	45	T1400-MQ2-120/HSK-A 63/0001	-	1,6	UE5-HSK63-79/1	5045174	1,5	T1400-2B-63/1	5041377
			T1400-MQ2-120/HSK-A 63/0002	-	2,3	UE5-HSK63-79/2	5039011	2,0	T1400-2B-63/2	5041378
			T1400-MQ2-120/HSK-A 63/0003	5132223	3,4	UE5-HSK63-79/3	5037303	3,0	T1400-2B-63/3	5037323
16	120	48	T1600-MQ2-120/HSK-A 63/0001	-	1,6	UE5-HSK63-74/1	5069074	1,5	T1600-2B-63/1	5041376
			T1600-MQ2-120/HSK-A 63/0002	5080820	2,3	UE5-HSK63-74/2	5039010	2,0	T1600-2B-63/2	5037356
			T1600-MQ2-120/HSK-A 63/0003	-	3,4	UE5-HSK63-74/3	5037327	3,0	T1600-2B-63/3	5037325
18	120	48	T1800-MQ2-120/HSK-A 63/0001	5069152	1,6	UE5-HSK63-74/1	5069074	1,5	T1800-2B-63/1	5041375
			T1800-MQ2-120/HSK-A 63/0002	-	2,3	UE5-HSK63-74/2	5039010	2,0	T1800-2B-63/2	5041236
			T1800-MQ2-120/HSK-A 63/0003	-	3,4	UE5-HSK63-74/3	5037327	3,0	T1800-2B-63/3	5037329
20	120	50	T2000-MQ2-120/HSK-A 63/0002	-	2,3	UE5-HSK63-70/2	-	2,0	T2000-2B-63/2	5041382
			T2000-MQ2-120/HSK-A 63/0003	-	3,4	UE5-HSK63-70/3	-	3,0	T2000-2B-63/3	5041400
			T2000-MQ2-120/HSK-A 63/0004	-	4,6	UE5-HSK63-70/4	5043481	4,0	T2000-2B-63/4	5037338

Im Lieferumfang enthalten: Übernahmeeinheit & Einstellschraube
 Delivery package: supply unit & setting screw

*Hinweis Wuchtgüte siehe Seite 14 Balancing Information, page 14



MMS 2-Kanal-System **Schrumpffutter**
 MQL 2-Channel-System **Shrink Chucks**

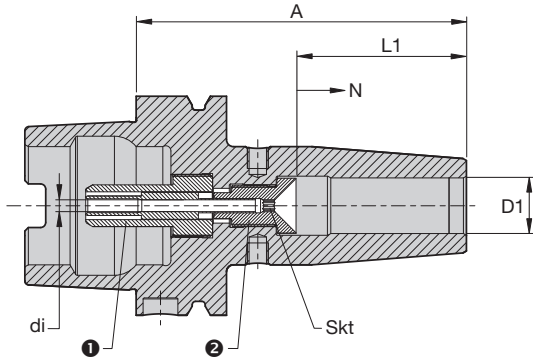

Schrumpffutter Shrink Chucks				G2.5/ 25.000			max. 24.000		CHIP	4,5°	Übernahmeinheit Supply unit ①		Axiale Einstellschraube Setting screw ②		
D1 [mm]	A [mm]	L1 [mm]	Bezeichnung Designation	Ident No.	di	UE-Type BILZ	Ident No.	Skt	AES-Type BILZ	Ident No.					
6	160	36	T0600-MQ2-160/HSK-A 63/0001	5069141	1,6	UE5-HSK63-130/1	5037370	1,5	T0600-2B-32/1	5037207					
			T0600-MQ2-160/HSK-A 63/0002	-	2,3	UE5-HSK63-130/2	5039133	2,0	T0600-2B-32/2	5041398					
8	160	36	T0800-MQ2-160/HSK-A 63/0001	5072395	1,6	UE5-HSK63-130/1	5037370	1,5	T0800-2B-40/1	5037266					
			T0800-MQ2-160/HSK-A 63/0002	-	2,3	UE5-HSK63-130/2	5039133	2,0	T0800-2B-40/2	5038976					
10	160	40	T1000-MQ2-160/HSK-A 63/0001	5069142	1,6	UE5-HSK63-125/1	-	1,5	T1000-2B-50/1	5041389					
			T1000-MQ2-160/HSK-A 63/0002	-	2,3	UE5-HSK63-125/2	5041254	2,0	T1000-2B-50/2	5037290					
12	160	45	T1200-MQ2-160/HSK-A 63/0001	5072399	1,6	UE5-HSK63-119/1	5072402	1,5	T1200-2B-63/1	5041379					
			T1200-MQ2-160/HSK-A 63/0002	-	2,3	UE5-HSK63-119/2	5041246	2,0	T1200-2B-63/2	5037301					
			T1200-MQ2-160/HSK-A 63/0003	-	3,4	UE5-HSK63-119/3	5041251	3,0	T1200-2B-63/3	5041250					
14	160	45	T1400-MQ2-160/HSK-A 63/0001	-	1,6	UE5-HSK63-119/1	5072402	1,5	T1400-2B-63/1	5041377					
			T1400-MQ2-160/HSK-A 63/0002	-	2,3	UE5-HSK63-119/2	5041246	2,0	T1400-2B-63/2	5041378					
			T1400-MQ2-160/HSK-A 63/0003	-	3,4	UE5-HSK63-119/3	5041251	3,0	T1400-2B-63/3	5037323					
16	160	48	T1600-MQ2-160/HSK-A 63/0001	5069149	1,6	UE5-HSK63-114/1	5069071	1,5	T1600-2B-63/1	5041376					
			T1600-MQ2-160/HSK-A 63/0002	-	2,3	UE5-HSK63-114/2	-	2,0	T1600-2B-63/2	5037356					
			T1600-MQ2-160/HSK-A 63/0003	-	3,4	UE5-HSK63-114/3	5102531	3,0	T1600-2B-63/3	5037325					
18	160	48	T1800-MQ2-160/HSK-A 63/0001	5069153	1,6	UE5-HSK63-114/1	5069071	1,5	T1800-2B-63/1	5041375					
			T1800-MQ2-160/HSK-A 63/0002	-	2,3	UE5-HSK63-114/2	-	2,0	T1800-2B-63/2	5041236					
			T1800-MQ2-160/HSK-A 63/0003	-	3,4	UE5-HSK63-114/3	5102531	3,0	T1800-2B-63/3	5037329					
20	160	50	T2000-MQ2-160/HSK-A 63/0002	5069154	2,3	UE5-HSK63-110/2	5069072	2,0	T2000-2B-63/2	5041382					
			T2000-MQ2-160/HSK-A 63/0003	-	3,4	UE5-HSK63-110/3	-	3,0	T2000-2B-63/3	5041400					
			T2000-MQ2-160/HSK-A 63/0004	-	4,6	UE5-HSK63-110/4	5101838	4,0	T2000-2B-63/4	5037338					
25	160	56	T2500-MQ2-160/HSK-A 63/0002	-	2,3	UE5-HSK63-99/2	-	2,0	T2500-2B-63/2	5041384					
			T2500-MQ2-160/HSK-A 63/0003	-	3,4	UE5-HSK63-99/3	-	3,0	T2500-2B-63/3	5041385					
			T2500-MQ2-160/HSK-A 63/0004	-	4,6	UE5-HSK63-99/4	5037346	4,0	T2500-2B-63/4	5037344					
32	160	60	T3200-MQ2-160/HSK-A 63/0002	-	2,3	UE5-HSK63-94/2	5069073	2,0	T3200-2B-63/2	5041386					
			T3200-MQ2-160/HSK-A 63/0003	5069156	3,4	UE5-HSK63-94/3	-	3,0	T3200-2B-63/3	5041387					
			T3200-MQ2-160/HSK-A 63/0004	-	4,6	UE5-HSK63-94/4	-	4,0	T3200-2B-63/4	5041388					

Im Lieferumfang enthalten: Übernahmeinheit & Einstellschraube
 Delivery package: supply unit & setting screw

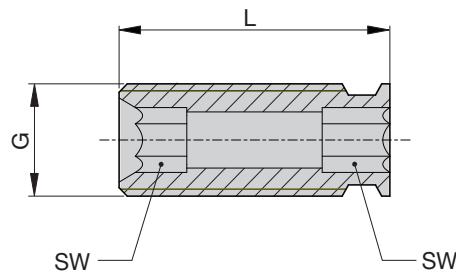

T... Einstellschrauben T... Adjusting screws					
Ø D [mm]	G	L	SW	Bezeichnung Designation	Ident No.
3	M6	16	3	BN158-0616-1.5	6954747
4	M6	10	3	BN158-0610	6946782
5	M6	10	3	BN158-0610	6946782
6	M5	18	2,5	T0600-2-M5x18	6947302
8	M6	20	3	T0800-2-M6x20	6947303
10	M8x1	20	4	T1000-2-M8x1x20	6952015
11	M8x1	20	5	T1000-2-M8x1x20	6952015
12	M10x1	15	5	T1200-2-M10x1x15	6952444
14	M10x1	15	5	T1200-2-M10x1x15	6952444
15	M12x1	20	6	T1600-2-M12x1x20	6952017
16	M12x1	20	6	T1600-2-M12x1x20	6952017
18	M12x1	20	6	T1600-2-M12x1x20	6952017
20	M16x1	20	8	T2000-2-M16x1x20	6952018
22	M16x1	20	8	T2000-2-M16x1x20	6952018
25	M16x1	20	8	T2000-2-M16X1x20	6952018
28	M16x1	20	8	T2000-2-M16X1x20	6952018
32	M16x1	20	8	T2000-2-M16X1x20	6952018

TSF... Einstellschrauben TSF... Adjusting screws					
Ø D [mm]	G	L	SW	Bezeichnung Designation	Ident No.
3	M6	16	3	BN158-0616-1.5	6954747
4	M6	10	3	BN158-0610	6946782
5	M6	10	3	BN158-0610	6946782
6	M5	15	2,5	T0600-2-M5x18	6952890
8	M6	16	3	T0800-2-M6x16	6950028
10	M8x1	15	4	T1000-2-M8x1x15	6952442
12	M10x1	15	5	T1200-2-M10x1x15	6952444
14	M10x1	15	5	T1200-2-M10x1x15	6952444
16	M12x1	15	6	T1600-2-M12x1x15	6952445
18	M12x1	20	6	T1600-2-M12x1x20	6952017
20	M16x1	15	8	T2000-2-M16x1x15	6952529
25	M16x1	15	8	T2000-2-M16x1x15	6952529

THD... Einstellschrauben THD... Adjusting screws					
Ø D [mm]	G	L	SW	Bezeichnung Designation	Ident No.
16	M12x1	20	6	T1600-2-M12x1x20	6952017
20	M16x1	20	8	T2000-2-M16x1x20	6952018
25	M16x1	20	8	T2000-2-M16x1x20	6952018
32	M16x1	20	8	T2000-2-M16x1x20	6952018

Messadapter zur Längenvoreinstellung

Measuring Adaptor for Length Presetting

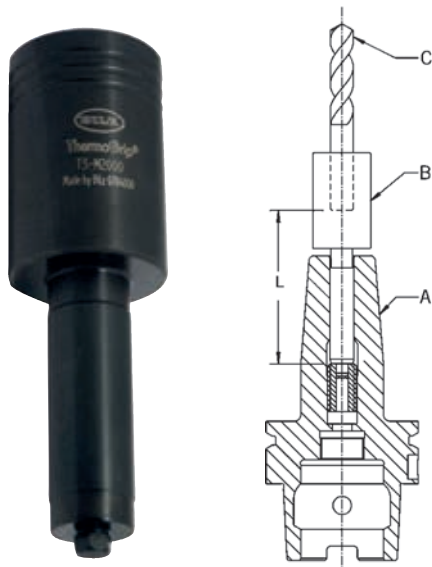

Kleiner Preis - große Wirkung

Der ThermoGrip® Messadapter ist der kostengünstige Einstieg in die Voreinstellung und zeichnet sich gegenüber komplexen Voreinstellgeräten durch Einfachheit und Vielseitigkeit aus. Unabhängig von der Spannvorrichtung können Sie die Länge im Werkzeughalter einstellen.

Einer für alle

Der ThermoGrip® Messadapter funktioniert auf jedem herkömmlichen Längenvoreinstellgerät.

Kostenreduzierung

Durch die einfache Bedienung kann Zeit bei der Voreinstellung eingespart werden. Der ThermoGrip® Messadapter gewährleistet Prozesssicherheit in der Fertigung durch höhere Maßhaltigkeit bei der Längenvoreinstellung.

Low Price – Big Effect

The ThermoGrip® Measuring Adaptor is the low cost entry into pre-setting and is characterized by its simple handling and versatility. The length of the tool holder can be preset independently by the clamping device.

One for all

The ThermoGrip® Measuring Adaptor works on all standard length presetting machines.

Cost reduction

Due to simple handling, time can be saved. The ThermoGrip® Measuring Adaptor guarantees process security in production due to higher dimensional accuracy at the length presetting.

T3-M...				
d1 [mm]	SW	L [mm]	Bezeichnung Designation	Ident No.
6	2,5	80	T3-M0600	6725959
8	3,0	80	T3-M0800	6725962
10	4,0	80	T3-M1000	6725963
12	5,0	80	T3-M1200-SW5	6726111
14	5,0	80	T3-M1400-SW5	6726112
16	6,0	80	T3-M1600	6725967
18	6,0	80	T3-M1800	6725968
20	8,0	80	T3-M2000	6725969
25	8,0	80	T3-M2500	6725970
32	8,0	80	T3-M3200	6725971

Messablauf:

Der Messadapter (B) wird in das ThermoGrip® Schrumpffutter (A) gesteckt und rastet in den Sechskant der Längenvoreinstellschraube ein.

Das Werkzeug (C) wird in den Messadapter (B) eingesetzt.

Durch Verdrehen des Messadapters (B) wird die Werkzeuglänge über die Nachstellschraube im Futter mit Hilfe eines Voreinstellgerätes bestimmt.

Der Messadapter (B) wird anschließend wieder aus dem ThermoGrip® Schrumpffutter (A) herausgenommen.

Das Differenzmaß (L) (L = 80 mm) muss beim Einstellen berücksichtigt werden. Dieser Vorhaltswert muss von der Gesamtlänge abgezogen werden.

Tip: Achten Sie beim Herausnehmen des Messadapters (B) darauf, dass Sie den Messadapter (B) nicht drehen. Ansonsten wird die Längennachstellschraube verstellt, und die Gesamtlänge ändert sich.

Als letzten Schritt setzen Sie das Werkzeug (C) ohne Messadapter (B) in die Vorweite der ThermoGrip® Schrumpffutter (A) ein und schrumpfen es auf dem ISG-Gerät Ihrer Wahl. Unser breites Geräte-Programm steht Ihnen zur Verfügung.

Measurement Process

The measuring adaptor (B) is put into the ThermoGrip® shrink chuck (A) and locks into the hexagon of the length presetting screw.

The tool (C) is inserted into the measuring adaptor (B).

By turning the measuring adaptor (B) the tool length is determined via the adjusting screw with the help of a presetting device.

The measuring adaptor (B) is then taken out of the ThermoGrip® shrink chuck.

The differential dimension (L) (L = 80 mm) has to be considered during adjustment. This stored value has to be deducted from the total length.

Tip: Make sure not to turn the measuring adaptor (B) when taking it out. Otherwise the length adjusting screw is displaced and the total length is readjusted.

As a last step, you put the tool (C) without measuring adaptor into the counterbore of the ThermoGrip® shrink chuck (A) and shrink it on the ISG machine of your own choice.

Universal Messadapter (MMS 1 + 2 Kanal) Universal Measuring Adaptor (MQL 1 + 2 Channel)

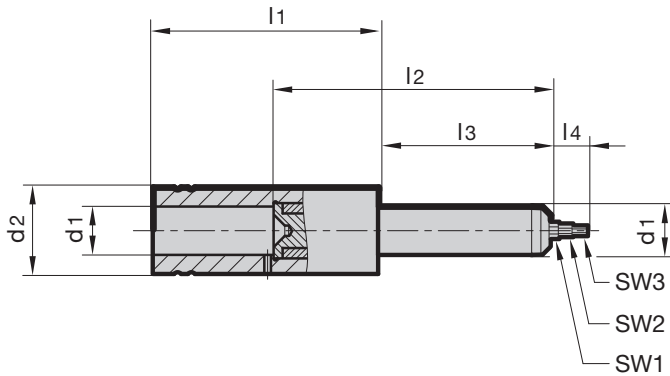

T3-M...										
Bezeichnung Designation	d1 [mm]	d2 [mm]	l1 [mm]	l2 [mm]	l3 [mm]	l4 [mm]	SW1	SW2	SW3	Ident No.
T3-M0600/0001	6	25	115	80	50	10	2,0	1,5	-	5046404
T3-M0600/0002	6	25	115	80	50	10	3,0	2,5	-	5046406
T3-M0600/0003	6	25	115	80	50	10	4,0	-	-	5046407
T3-M0800/0001	8	25	115	80	50	10	2,0	1,5	-	5046461
T3-M0800/0002	8	25	115	80	50	10	3,0	-	-	5046462
T3-M0800/0003	8	25	115	80	50	10	4,0	-	-	5046463
T3-M1000/0001	10	25	115	80	50	10	2,0	1,5	-	5046464
T3-M1000/0002	10	25	115	80	50	10	4,0	3,0	-	5046466
T3-M1200/0001	12	25	115	80	50	10	3,0	2,0	1,5	5046468
T3-M1200/0002	12	25	115	80	50	10	5,0	4,0	-	5046469
T3-M1400/0001	14	25	115	80	50	10	3,0	2,0	1,5	5046470
T3-M1400/0002	14	25	115	80	50	10	5,0	4,0	-	5046471
T3-M1600/0001	16	25	120	85	55	10	3,0	2,0	1,5	5046472
T3-M1600/0002	16	25	120	85	55	10	6,0	5,0	4,0	5046473
T3-M1800/0001	18	30	120	85	55	10	3,0	2,0	1,5	5046474
T3-M1800/0002	18	30	120	85	55	10	6,0	5,0	4,0	5046475
T3-M2000/0001	20	30	135	90	65	10	4,0	3,0	2,0	5046476
T3-M2000/0002	20	30	135	90	65	10	8,0	5,0	-	5046477
T3-M2500/0001	25	35	140	100	70	10	4,0	3,0	2,0	5046478
T3-M2500/0002	25	35	140	100	70	10	8,0	5,0	-	5046479
T3-M3200/0001	32	45	150	100	70	10	4,0	3,0	2,0	5046480
T3-M3200/0002	32	45	150	100	70	10	8,0	5,0	-	5046482

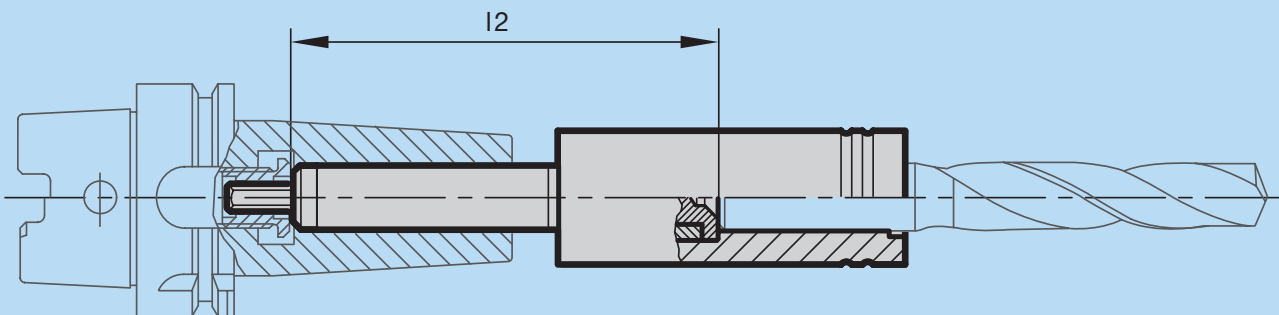

Längeneinstellhülsen Length Adjusting Sleeve



Mit der Längeneinstellhülse kann genau bestimmt werden, wie weit die Schneidwerkzeuge aus dem Schrumpffutter herausragen. Hierzu wird der Schiebestößel auf das gewünschte Skalenmaß eingestellt und festgeklemmt. Dann wird das Schneidwerkzeug in die Bohrung geführt, gegen den Kunststoffanschlag gedrückt und geklemmt. So wird der Fräser in das erhitze Schrumpffutter bis auf Anschlag eingeführt.

The length adjusting sleeve makes it possible to determine exactly how far the cutting tools come out of the shrink chuck. The slide is adjusted to the required length and clamped in.

The cutting tool is then inserted into the bore hole, pressed against the plastic stop and clamped. This way the cutter is inserted into the hot shrink chuck up to the stop.

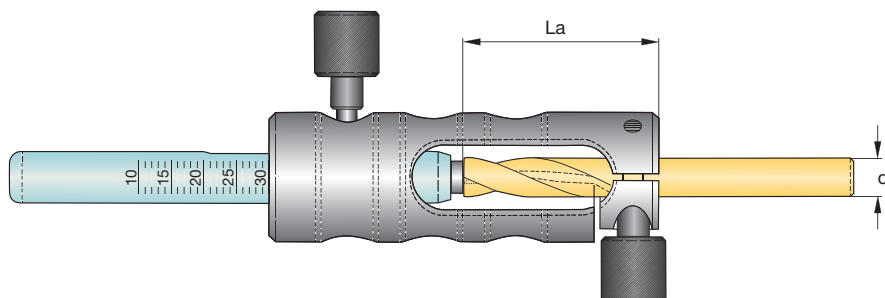

T3-LS...			
d Werkzeug Tool	La	Bezeichnung Designation	Ident No.
3 mm	5 – 25 mm	T3-LS0300-5-25	5021284
3 mm	30 – 50 mm	T3-LS0300-30-50	5032090
4 mm	5 – 25 mm	T3-LS0400-5-25	5021285
4 mm	30 – 50 mm	T3-LS0400-30-50	5032091
5 mm	5 – 25 mm	T3-LS0500-5-25	5021286
5 mm	30 – 50 mm	T3-LS0500-30-50	5032092
6 mm	10 – 35 mm	T3-LS0600-10-35	5021287
6 mm	35 – 60 mm	T3-LS0600-35-60	5032093
8 mm	10 – 35 mm	T3-LS0800-10-35	5021288
8 mm	35 – 60 mm	T3-LS0800-35-60	5032094
10 mm	15 – 50 mm	T3-LS1000-15-50	5021289
10 mm	35 – 60 mm	T3-LS1000-35-60	5032095
12 mm	15 – 50 mm	T3-LS1200-15-50	5021290
16 mm	30 – 65 mm	T3-LS1600-30-65	5032102

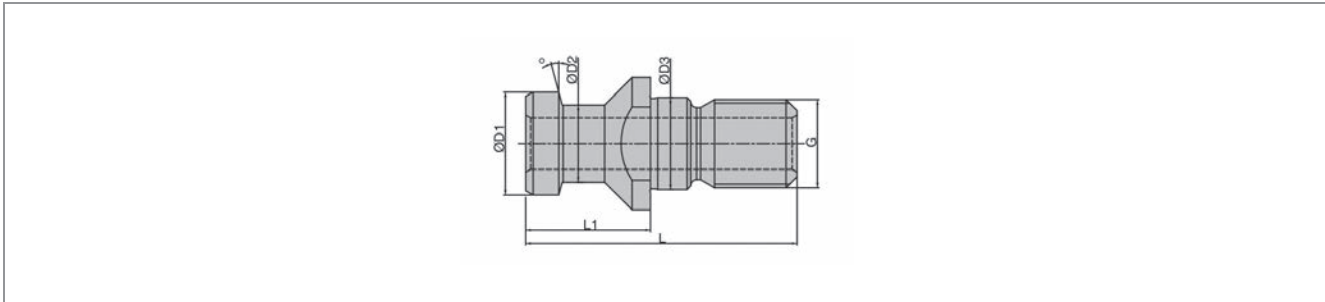

Form AD Mit Durchgangsbohrung, ohne O-Ring With through hole, without O-ring

G	D1 [mm]	D2 [mm]	D3 [mm]	L [mm]	L1 [mm]	O	Bezeichnung Designation	Ident No.
M 12	13	9	13	44	24	15°	BN 164-SK 30	6733614
M 16	19	14	17	54	26	15°	BN 164-SK 40	6733615
M 24	28	21	25	74	34	15°	BN 164-SK 50	6733616

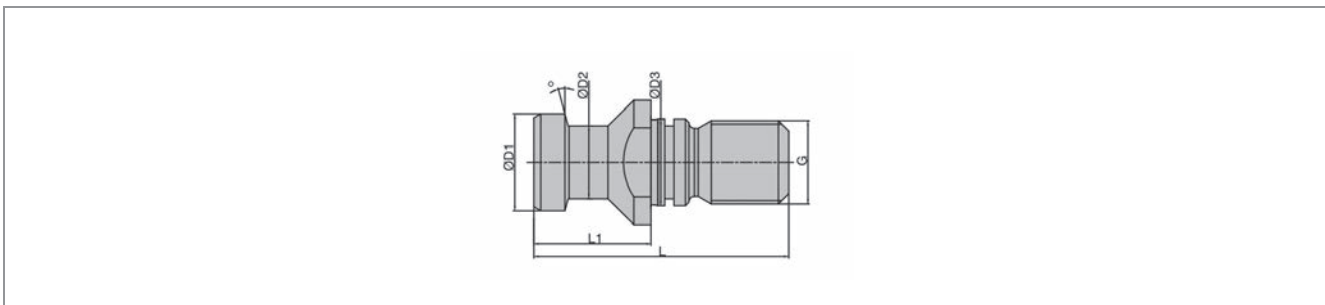

Form AF Ohne Durchgangsbohrung, inkl. O-Ring Without through hole, incl. O-ring

G	D1 [mm]	D2 [mm]	D3 [mm]	L [mm]	L1 [mm]	O	Bezeichnung Designation	Ident No.
M 16	19	14	17	54	26	15°	BN 164B-SK 40	5056290
M 24	28	21	25	74	34	15°	BN 164B-SK 50	5056292

Coming soon
The new Bilz Shop.

Sie erreichen unseren neuen Shop bald unter www.Bilz.de
You will reach the new shop under www.Bilz.com

Anzugsbolzen DIN ISO 7388-3

Pull Stud DIN ISO 7388-3

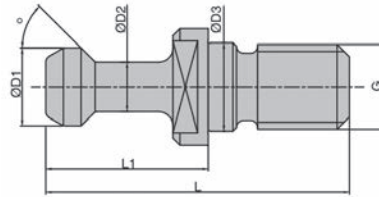

Form JD Mit Durchgangsbohrung, ohne O-Ring With through hole, without O-ring

G	D1 [mm]	D2 [mm]	D3 [mm]	L [mm]	L1 [mm]	O	Bezeichnung Designation	Ident No.
M 12	11	7	12,5	43	23	45°	BN 164 - BT30	6733617
M 16	15	10	17	60	35	45°	BN 164 - BT40	6733618
M 24	23	17	25	85	45	45°	BN 164 - BT50	6733619
M 12	11	7	12,5	43	23	60°	BN 164 - BT30 - 60	4600614
M 16	15	10	17	60	35	60°	BN 164 - BT40 - 60	4600882
M 24	23	17	25	85	45	60°	BN 164 - BT50 - 60	4601402
M 16	15	10	17	60	35	90°	BN 164 - BT40 - 90	4600959
M 24	23	17	25	85	45	90°	BN 164 - BT50 - 90	4601404

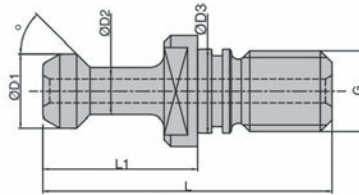

Form JD Mit Durchgangsbohrung, inkl. O-Ring With through hole, incl. O-ring

G	D1 [mm]	D2 [mm]	D3 [mm]	L [mm]	L1 [mm]	O	Bezeichnung Designation	Ident No.
M 12	11	7	12,5	43	23	45°	BN 164 - BT30	4600613
M 16	15	10	17	60	35	45°	BN 164 - BT40	4600957
M 24	23	17	25	85	45	45°	BN 164 - BT50	4601460
M 12	11	7	12,5	43	23	60°	BN 164 - BT30 - 60	5084973
M 16	15	10	17	60	35	60°	BN 164 - BT40 - 60	4600958
M 24	23	17	25	85	45	60°	BN 164 - BT50 - 60	4601461
M 16	15	10	17	60	35	90°	BN 164 - BT40 - 90	5084974
M 24	23	17	25	85	45	90°	BN 164 - BT50 - 90	4602462

Montage Kühlmittelübergabe - Satz

Assembly Instructions Coolant Transfer Set



HSK

CAT

AD/ADF

JD/JDF/BT/FBT

PSC

TSFV

LNE/VIDAT

TER/TERV

MMS/MQL

Appendix

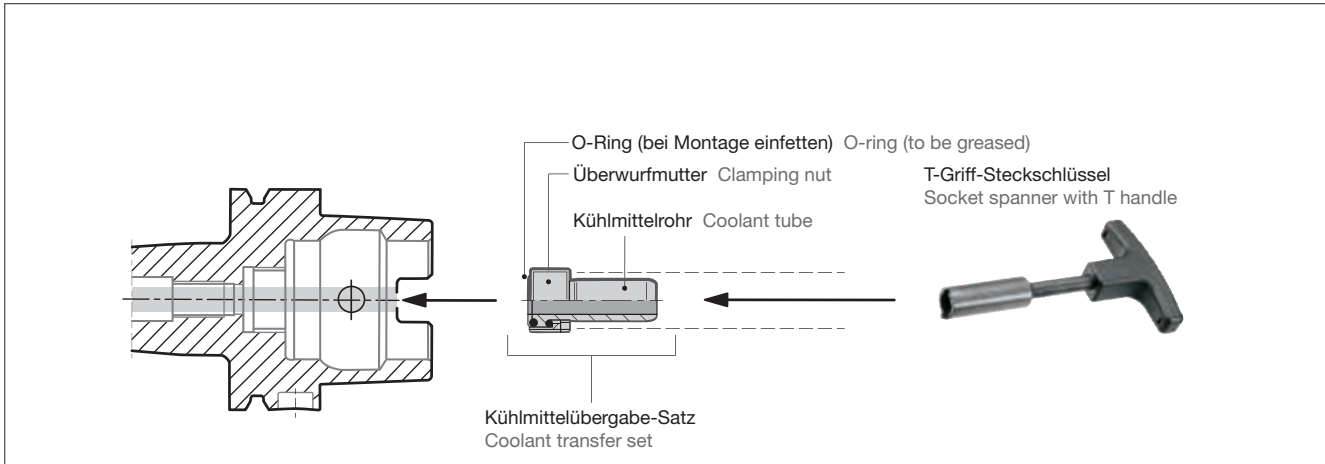

1. Das HSK-Futter muss sauber und frei von Spänen und Beschädigungen sein.
The HSK shank must be clean and free from swarf and damage.
2. Die O-Ringe vor der Montage einfetten.
Grease the O-rings before assembly.
3. Den Kühlmittelübergabe - Satz vollständig (Kühlmittelrohr, Überwurfmutter und 2 O-Ringe) mit Hilfe des Steckschlüssels zentrisch in den HSK einfügen.
Completely insert the coolant transfer set (coolant tube, clamping nut and 2 O-rings) centrally into the HSK.
4. Den Kühlmittelübergabe - Satz / die Kühlmittelübergabe - Einheit einschrauben und fest anziehen (Anzugsmoment s. Tabelle unten).
Screw in the coolant transfer set/unit.
5. Das Kühlmittelrohr auf radiale Beweglichkeit prüfen.
Check the coolant tube for radial movement.

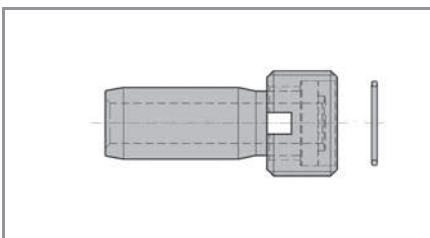

Kühlmittelrohr Coolant pipe		
Größen Size	Bezeichnung Designation	Ident No.
HSK25	UE4 HSK25	5100005
HSK32	UE4 HSK32	5064893
HSK40	UE4 HSK40	5028425
HSK50	UE4 HSK50	5028426
HSK63	UE4 HSK63	5025376
HSK80	UE4 HSK80	5028427
HSK100	UE4 HSK100	5028428
HSK125	UE4 HSK125	5064893

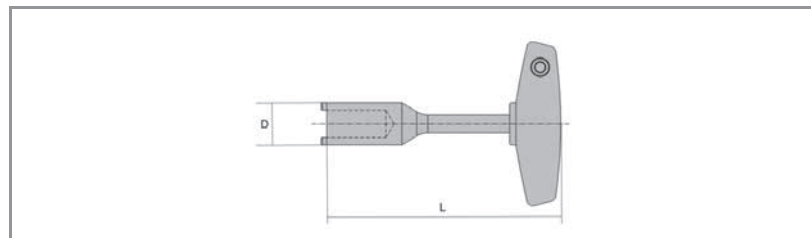

Montageschlüssel für Kühlmittelrohr Installation wrench for coolant pipe				
Größen Size	D [mm]	L [mm]	Max. Anzugsmoment Max. torque [Nm]	Ident No.
HSK25	6,8	132	3	5100007
HSK32	8,5	115	7	6738740
HSK40	10,5	115	11	6738741
HSK50	14,5	115	15	6738422
HSK63	16,5	136	20	6738421
HSK80	18,5	136	25	6738095
HSK100	22,0	136	30	6738303
HSK125	24,4	177	30	5169476

Zur Kühlübergabe bei HSK-Werkzeugen inkl. Runddichtung DIN 3770 und Überwurfmutter
For coolant transfer for HSK tools incl. round gasket DIN 3770 and union nut.

Wechselscheiben einteilig
Pole discs one-piece



*) im Lieferumfang der Spule 2
ISGS3400-2 Ident No. 5129760 enthalten
always delivered with coil 2 ISGS3400-2
Ident No. 5129760

Für eine optimale Abschirmung des Magnetfeldes zwischen Spule und Werkzeugschaft
For optimal shielding of the magnetic field between coil and tool shank

Bezeichnung Designation	Spann-Ø Clamping-Ø	ISG1000	ISG 2400 Series Ident No.	ISG 3400 Series	
				Spule 1	Spule 2
ISGS1001-2	6,0 – 16 mm	5094533	–	–	–
ISGS2201-1	3,0 – 5,9 mm	6725758	6725758	–	–
ISGS2201-2	6,0 – 12 mm	–	6725759	–	–
ISGS2201-3	12,1 – 20 mm	–	6725760	–	–
ISGS3201-0	3,0 – 5,9 mm	–	–	6726157	–
ISGS3201-1	6,0 – 12 mm	–	–	6726143	–
ISGS3201-2	12,1 – 22 mm	–	–	6726144	–
ISGS3201-3	22,1 – 32 mm	–	–	6726145	–
ISGS3401-100X27X10	Durchlass 27 mm	–	–	–	5137388
ISGS3401-72X100X35X20*)	Durchlass 35 mm	–	–	–	5137383
ISGS3401-100X54X10	Durchlass 54 mm	–	–	–	5137387

Wechselscheiben zweiteilig
Pole discs two-piece

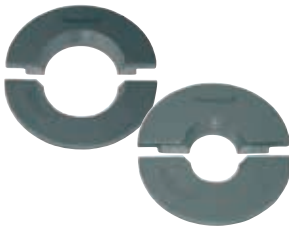

Für die Verwendung bei größerem Schneidendurchmesser als der zu schrumpfende
Schaftdurchmesser
For use when the cutting diameter is bigger than the shrinking diameter

Bezeichnung Designation	Spann-Ø Clamping-Ø	ISG1000	ISG 2400 Series Ident No.	ISG 3400 Series	
				Spule 1	Spule 2
ISGS2201GT-1	3,0 – 5,9 mm	9074537	9074537	–	–
ISGS2201GT-2	6,0 – 12,0 mm	9074538	9074538	–	–
ISGS2201GT-3	12,1 – 20,0 mm	9074539	9074539	–	–
ISGS3201GT-0	3,0 – 5,9 mm	–	–	9074540	–
ISGS3201GT-1	6,0 – 12,0 mm	–	–	9074541	–
ISGS3201GT-2	12,1 – 22,0 mm	–	–	9074542	–
ISGS3201GT-3	22,1 – 32,0 mm	–	–	9074543	–
ISGS3401GT-72X100X22X20	Durchlass 22 mm	–	–	–	5137396
ISGS3401GT-72X100X35X20	Durchlass 35 mm	–	–	–	5137398
ISGS3401GT-100X54X10	Durchlass 54 mm	–	–	–	5137394

Wechselscheiben TSF
Pole discs TSF



Das TSF-Set ermöglicht das Schrumpfen der TSF-Schrumpffutter auf dem Schrumpfgerät.
Die TSF-Scheiben sorgen für eine optimale Abschirmung des Magnetfeldes zwischen Spule
und Werkzeugschaft. Somit ist das prozesssichere und schonende Schrumpfen von
TSF-Schrumpffuttern gewährleistet.

The TSF set allows TSF shrink chucks to be shrunk using the shrink machine.
The TSF discs provide optimal shielding of the magnetic field between coil and tool shank.
This guarantees safe and reliable shrinking of the TSF shrink chucks.

Bezeichnung Designation	Spann-Ø Clamping-Ø	ISG1000	ISG 2400 Series Ident No.	ISG 3400 Series	
ISGS...201-TSF-SET besteht aus folgenden Teilen ISGS...201-TSF-SET consists of the following parts		9102759	9102759	9102645	
TVP-ISG-TSF Aufbewahrungsbox TVP-ISG-TSF storage box		6955194	6955194	6955194	
ISGS...201-TSF03	3 mm	9102727	9102727	9088924	
ISGS...201-TSF04	4 mm	9102728	9102728	9088925	
ISGS...201-TSF05	5 mm	9102749	9102749	9102646	
ISGS...201-TSF06	6 mm	9102750	9102750	9088926	
ISGS...201-TSF08	8 mm	9102752	9102752	9088927	
ISGS...201-TSF10	10 mm	9102753	9102753	9088928	
ISGS...201-TSF12	12 mm	9102754	9102754	9088980	
ISGS...201-TSF14	14 mm	9102755	9102755	9102647	
ISGS...201-TSF16	16 mm	9102756	9102756	9088981	
ISGS...201-TSF18	18 mm	9102757	9102757	9102648	
ISGS...201-TSF20	20 mm	9102758	9102758	9088982	
ISGS3201-TSF25	25 mm	–	–	9088983	

Programmaktualität

Im Rahmen der kontinuierlichen Aktualisierung unseres Produktprogrammes nehmen wir nicht nur neue und damit technisch bessere Produkte im Programm auf, sondern führen auch eine intensive Programmbereinigung durch. Es kann also im Einzelfall passieren, dass wir einen von Ihnen bestellten Artikel nicht mehr lagermäßig führen. Sie erhalten dann von uns in der Regel ein technologisch besseres Produkt, mindestens aber eine gleichwertige Alternative. In Zweifelsfällen wird sich unser Verkaufsteam mit Ihnen in Verbindung setzen, um eine für Sie optimale Ausführung zu bestimmen. Durch diese Vorgehensweise ist sichergestellt, dass Sie stets mit Werkzeugen beliefert werden, die technisch auf dem neuesten Stand sind.

Eine Verpflichtung zur Lieferung von noch im Katalog oder in der Preisliste abgebildeten Werkzeugen, die intern aber bereits programmbereinigt wurden, übernehmen wir deshalb nicht.

Preise

Dieser Katalog enthält keine Preise. Diese entnehmen Sie bitte der jeweils gültigen Preisliste.

Mindestauftragswert

Wir bitten um Verständnis, dass wir Aufträge bis zu einem netto Gesamtwarenwert unter € 50,- nur gegen eine zusätzliche Bearbeitungsgebühr in Höhe von € 20,- ausführen können. Die Mindestbestellmenge bei Sonderartikeln beträgt 3 Stück.

Sonderformen

Sollten Sie eines Ihrer Bearbeitungsprobleme nicht mit einem unserer lagergängigen Werkzeuge lösen können, bieten wir Ihnen Sonderformen oder zeichnungsgebundene Werkzeuge auf Anfrage an. Unsere Anwendungstechniker beraten Sie gern.

Updating of our product range

In the course of updating our product range, we are not only constantly adding new and technically improved products to our programme, but at the same time we are also continually reassessing the product range. In exceptional cases, it is possible that we no longer have the product you order on stock.

You will then receive a technically improved product or an equivalent alternative. In any case of doubt, our sales team will contact you in order to determine the optimal version for you. We ensure that you will always get the most updated tools.

We therefore do not assume any obligation to supply tools appearing in the catalogue and/or in the price list which have already been adjusted out of the system internally.

Bilz and its partners shall have no liability for indirect, incidental or consequential errors in this catalog.

Prices

For prices, please refer to the current price list.

Minimum order value

An additional handling fee of EUR 20.00 will be charged for orders with a total net order value of less than EUR 50.00.

The minimum order quantity for special tools is 3 pcs.

Special designs

If you find that your specific machining problems cannot be resolved with any of our permanently stocked tools, then we can supply special designs or tools made according to drawings. Our application technicians will be glad to help you.

Nachdruck, auch auszugsweise, ist nur mit unserer Zustimmung gestattet. Alle Rechte vorbehalten. Irrtümer, Satz- oder Druckfehler berechtigen nicht zu irgendwelchen Ansprüchen. Abbildungen, Ausführungen und Maße entsprechen dem neuesten Stand bei Herausgabe dieser Druckschrift. Technische Änderungen müssen vorbehalten sein. Die bildliche Darstellung der Produkte muss nicht in jedem Falle und in allen Einzelheiten dem tatsächlichen Aussehen entsprechen.

This publication may not be reprinted in whole or part without our permission. All rights reserved. No rights may be derived from any errors in content or from typographical or typesetting errors. Diagrams, features, and dimensions represent the current status of the date of issue on this catalog. We reserve the right to make technical changes. The visual appearance of the products may not necessarily correspond to the actual appearance in all cases or in every detail.



日 易 暉 机 械

台北市敦化南路二段40號2樓 郵遞區號: 106
2/F, No. 40, Sec. 2, Tun Hwa S. Road,
Taipei, Taiwan Zip: 106
Tel: 886-2-2705-8448
Fax: 886-2-2700-8430

上海市天鑰橋路325號嘉匯國際廣場A幢2101-2102室 郵編: 200030
Room 2101-2102, Gateway International Plaza, Building A, No.325, Tian
Yao Qiao Road, Shanghai, China Zip: 200030
Tel: 86-21-3363-2088 & 3363-2099
Fax: 86-21-3363-3303

上海辦事處	電話: 86-21-3363-2088	傳真: 86-21-3363-3303
天津辦事處	電話: 86-22-5817-3069	傳真: 86-22-5817-3069
成都辦事處	電話: 86-28-8526-6681	傳真: 86-28-8526-6684
重慶辦事處	電話: 86-23-6757-3205	傳真: 86-23-6757-3207
長春辦事處	電話: 86-431-8461-7085	傳真: 86-431-8461-7087
外高橋保稅庫	電話: 86-21-5868-3075	傳真: 86-21-5868-3076

台北辦事處	電話: 886-2-2705-8448	傳真: 886-2-2700-8430
-------	---------------------	---------------------