



ALLIED MACHINE & ENGINEERING

为当今制造业提供制孔解决方案



镗孔



铰孔



抛光



螺纹加工



特殊应用



T-A[®] 钻削系统- RCA 冷却剂转换器

► 钻削
可更换刀片钻削系统

旋转冷却剂转换器 (RCA)

莫氏锥柄

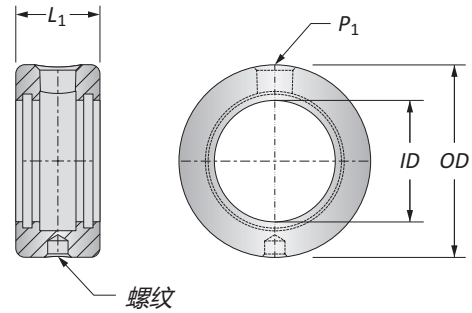

| 刀柄系列 | ID | OD | L ₁ | 驱动杆螺纹 | P ₁ | 零件号 | 最高推荐转速 | RCA O形圈 | | |
|------|-------|-------|----------------|-------|----------------|------|-----------|---------|---------|------------|
| | | | | | | | | 套件零件号** | 替换 | |
| i | Y、Z、0 | 3/4 | 1-3/4 | 7/8 | 5/16 - 18 | 1/8 | ▲ 2T-2SR | 3500 | 2T1-2SR | 2T1-2OR-10 |
| | 1、2 | 1 | 2-1/8 | 1-1/8 | 5/16 - 18 | 1/8 | ▲ 2T-3SR | 2500 | 2T1-3SR | 2T1-3OR-10 |
| | 2、3、4 | 1-1/4 | 2-1/2 | 1-3/8 | 3/8 - 16 | 1/4 | ▲ 2T-4SR | 2000 | 2T1-4SR | 2T1-4OR-10 |
| | 3、4 | 1-3/4 | 3 | 1-3/8 | 3/8 - 16 | 1/4 | ▲ 2T-5SR | 1500 | 2T1-5SR | 2T1-5OR-10 |
| | 5、7 | 2-1/4 | 3-3/4 | 1-3/4 | 1/2 - 13 | 1/2 | ▲ 2T-6SR | 1100 | 2T1-6SR | 2T1-6OR-10 |
| m | Y、Z、0 | 19.05 | 44.45 | 22.23 | M8 x 1.25 | 1/8* | ▲ 2T-2SRM | 3500 | 2T1-2SR | 2T1-2OR-10 |
| | 1、2 | 25.40 | 53.97 | 28.57 | M8 x 1.25 | 1/8* | ▲ 2T-3SRM | 2500 | 2T1-3SR | 2T1-3OR-10 |
| | 2、3、4 | 31.75 | 63.50 | 34.92 | M10 x 1.50 | 1/4* | ▲ 2T-4SRM | 2000 | 2T1-4SR | 2T1-4OR-10 |
| | 3、4 | 44.45 | 76.20 | 34.92 | M10 x 1.50 | 1/4* | ▲ 2T-5SRM | 1500 | 2T1-5SR | 2T1-5OR-10 |
| | 5、7 | 57.15 | 95.27 | 44.45 | M12 x 1.75 | 1/2* | ▲ 2T-6SRM | 1100 | 2T1-6SR | 2T1-6OR-10 |

*BSP和ISO 7-1螺纹

**RCA维修套件包括 (2个) O形圈、(2个) 卡环和 (2个) 推力垫圈

注释：最大推荐压力为600 PSI (42 bar)

注释：上述建议基于水基和油基冷却剂

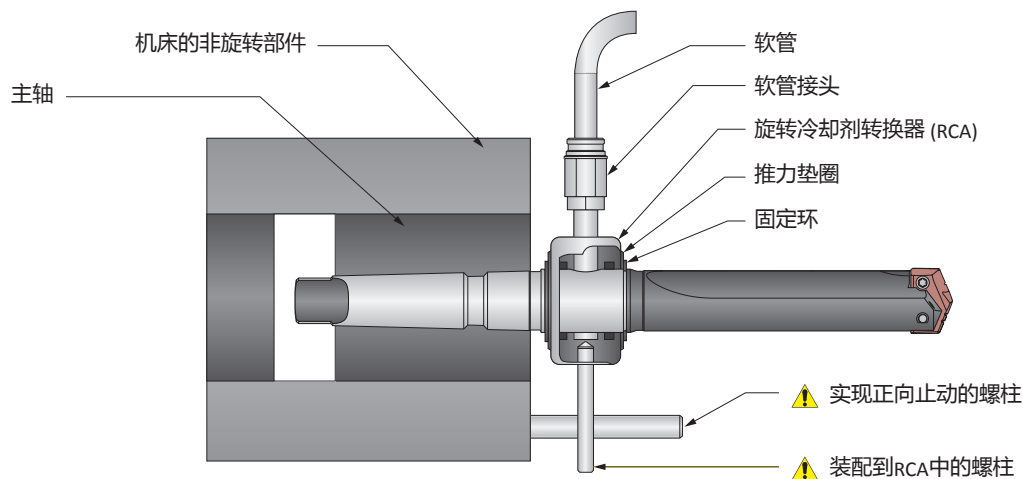

i = 英制 (in)

m = 公制 (mm)

O形圈以每包10个销售

警告 RCA在钻削过程中旋转可能导致软管和/或软管接头故障、机械损坏和/或严重伤害。为了避免上述情况，在钻削时使用RCA和正向止动螺柱。我们也可针对您的具体应用提供工厂技术援助。

United States

Allied Machine & Engineering

120 Deeds Drive
Dover OH 44622
United States

Phone:
+1.330.343.4283

Fax:
+1.330.602.3400

Toll Free USA and Canada:
800.321.5537

Toll Free USA and Canada:
800.223.5140

Allied Machine & Engineering

485 W Third Street
Dover OH 44622
United States

Phone:
+1.330.343.4283

Fax:
+1.330.364.7666
(Engineering Dept.)

Toll Free USA and Canada:
800.321.5537

Europe

Allied Machine & Engineering Co. (Europe) Ltd.

93 Vantage Point
Pensnett Estate
Kingswinford
West Midlands
DY6 7FR England

Phone:
+44 (0) 1384.400900

Wohlhaupter GmbH

Maybachstrasse 4
Postfach 1264
72636 Frickenhausen
Germany

Phone:
+49 (0) 7022.408.0

Fax:
+49 (0) 7022.408.212

Asia

Wohlhaupter India Pvt. Ltd.

B-23, 2nd Floor
B Block Community Centre
Janakpuri, New Delhi - 110058
India

Phone:
+91 (0) 11.41827044



日易晖 机械

GOLDEN CARBIDE PRECISION

台北市大安區敦化南路二段40號2樓 郵遞區號: 106

上海市天鑰橋路325號嘉匯國際廣場A棟2101-2102室 郵編: 200030

台北: 886-2-2705-8448

台中: 886-4-2463-8159

上海: 86-21-3363-2088

天津: 86-22-5817-3069

成都: 86-28-8526-6681

長春: 86-431-8461-7085

重慶: 86-23-6757-3205

外高橋保稅庫: 86-21-5868-3075

Website: www.goldencarbide.com

www.alliedmachine.com

Allied Machine & Engineering is registered by DQS to ISO 9001 10001329

Copyright © 2021 Allied Machine and Engineering Corp.

All rights reserved

Publish Date: January 2023