

Plattenhalter – Semistandard
Insert holder – semi-standard
Porte-plaque – semi-standard

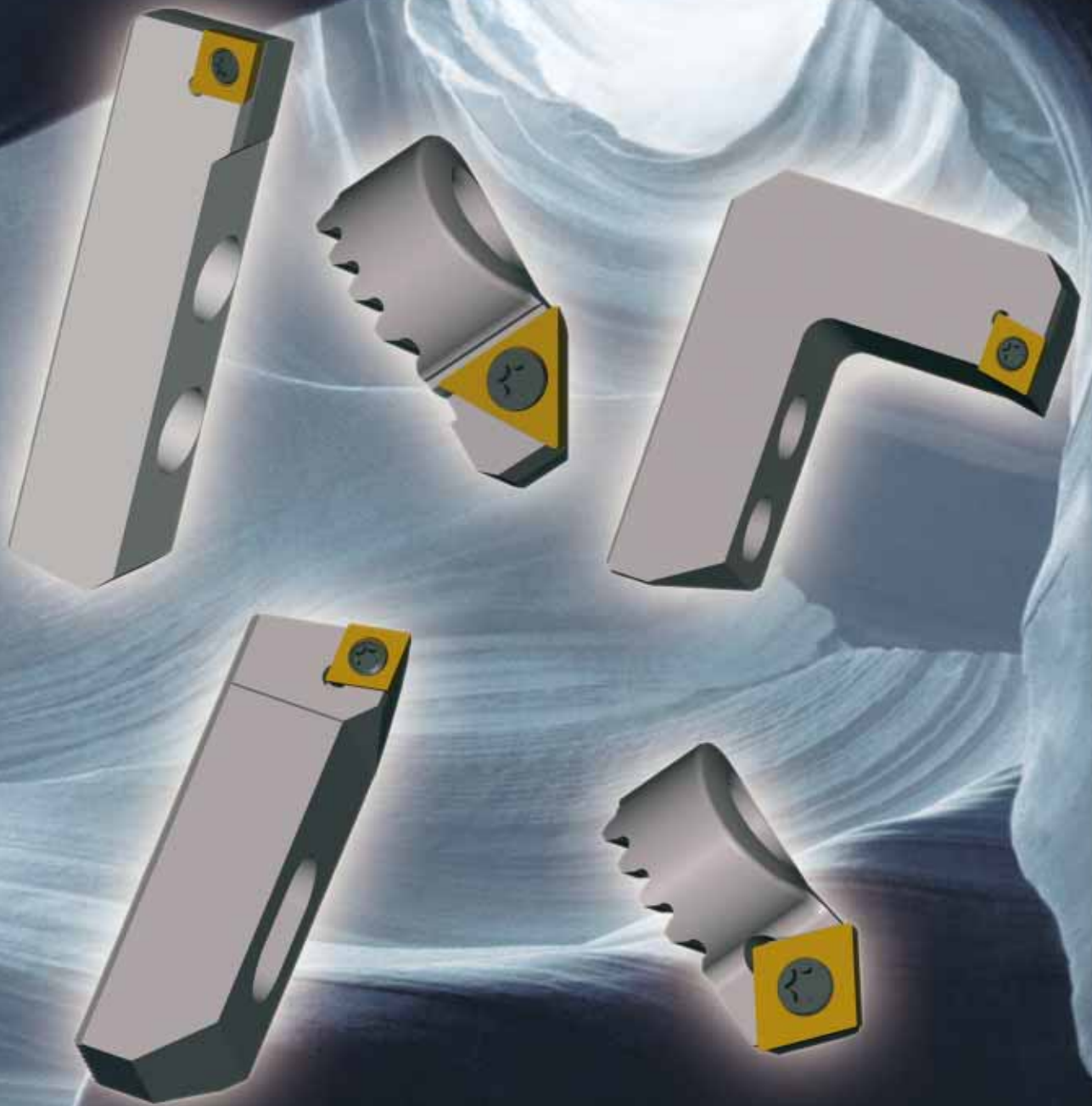

WOHLHAUPTER

Für Ihren Erfolg.

Auf die Vielfalt kommt es an!
It depends on diversity!
C'est selon de la diversité!

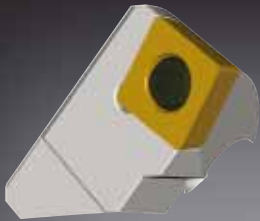

Das vorliegende Handbuch zeigt Ihnen einen Auszug aus unserem vielseitigen Semi-Standard-Plattenhalterprogramm. Weitere Ausführungen sind auf Anfrage lieferbar.

Plattenhalter aus unserem Standard-Programm finden Sie in unserem Systemwerkzeug-Katalog **MULTI BORE**® (90100). Nutzen Sie außerdem unseren Internet-Service: Hier finden Sie zusätzlich umfangreiche Daten über unser Plattenhalter-Programm als Downloads.

Gerne stehen Ihnen unsere Fachberater für ein Beratungsgespräch zur Verfügung.

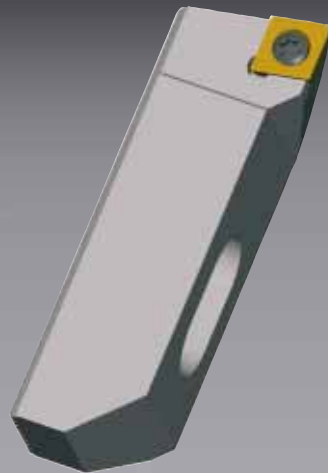

This manual contains an extract from our versatile semi-standard range of insert holders. Other versions can be supplied on request.

*Insert holders from our standard range are contained in our **MULTI BORE**® system tools catalogue (90100). You can also visit our website where you will find additional extensive data on our range of insert holders which you can download.*

Our specialist advisers are of course available to provide you with technical advice.

Le présent manuel contient un extrait de notre programme de porte plaquettes existant en version standard et semi standard. D'autres versions sont livrables sur demande.

Les porte plaquettes de notre programme standard sont inclus dans le catalogue Système d'outils **MULTI BORE**® (90100). Utilisez notre service Internet: vous y trouverez un nombre considérable d'informations concernant notre programme de porte plaquettes que vous pourrez "down-loader".

Nos techniciens d'application se tiennent volontiers à votre disposition pour toutes informations complémentaires et conseils d'utilisation.

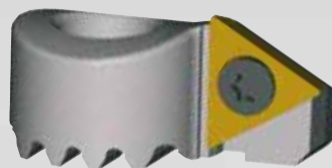

WOHLHAUPTER

Für Ihren Erfolg.

für Kerbzahnkörper
for serrated tool body
 pour corps crantés
148... / 349...

höhenversetzt*
*staggered in height**
 décalage en hauteur*

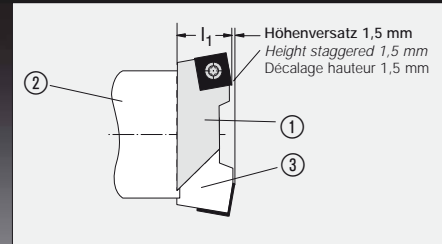

für Werkzeuge ② <i>for boring tools</i> pour outils d'alésage	Ausdrehbereich <i>Boring range</i> Capacité d'alésage	WSP-Form <i>Insert form</i> Forme de plaquette	Ausführung <i>Type</i> Modèle	Bestell-Nr. ① <i>Order Number</i> No de cde.	Bestell-Nr. Standard ③ <i>Order Number standard</i> No de cde. standard
	A		l ₁		
148 001	29 – 37	112	15,5	268 001	151 011
148 002	36 – 44	112	15,5	268 002	151 012
148 003	43 – 54	113	18,5	268 003	151 013
148 004	53 – 66	113	18,5	268 004	151 014
148 005	65 – 83	113	18,5	268 005	151 015
148 006	82 – 103	113	28,5	268 006	151 036
148 007	100 – 130	113	28,5	268 007	151 037
148 007	125 – 155	113	28,5	268 008	151 038
148 009	150 – 205	113	28,5	268 008	151 038
349 001	200 – 280				
349 002	275 – 355				
349 003	350 – 430				
349 004	425 – 505	113	28,5	149 082	149 089
349 005 + 349 014	465 – 745				
349 006 + 349 014	740 – 1020				

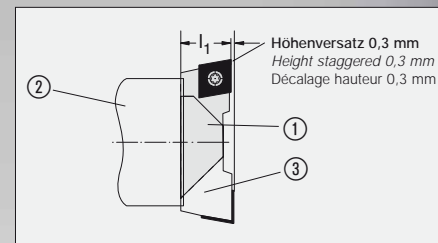

für Werkzeuge ② <i>for boring tools</i> pour outils d'alésage	Ausdrehbereich <i>Boring range</i> Capacité d'alésage	WSP-Form <i>Insert form</i> Forme de plaquette	Ausführung <i>Type</i> Modèle	Bestell-Nr. ① <i>Order Number</i> No de cde.	Bestell-Nr. standard ③ <i>Order Number standard</i> No de cde. standard
	A		l ₁		
349 001	200 – 280				
349 002	275 – 355				
349 003	350 – 430				
349 004	425 – 505	104	29,3	149 083	149 099
349 005 + 349 014	465 – 745				
349 006 + 349 014	740 – 1020				
349 001	200 – 280				
349 002	275 – 355				
349 003	350 – 430				
349 004	425 – 505	105	29,3	149 084	149 093
349 005 + 349 014	465 – 745				
349 006 + 349 014	740 – 1020				

für Kerbzahnkörper
for serrated tool body
pour corps crantés
148...

zum Ausdrehen, WSP-Form 103, Anstellwinkel 75°
for boring, insert form 103, approach angles 75°
 pour alésage, forme de plaquette 103, angles d'attaque 75°

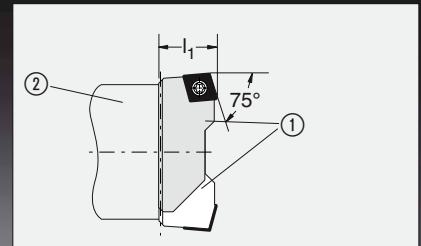

für Werkzeuge ② <i>for boring tools</i> pour outils d'alésage	Ausdrehbereich <i>Boring range</i> Capacité d'alésage A	WSP-Form <i>Insert form</i> Forme de plaquette	Ausführung <i>Type</i> Modèle l_1	Bestell-Nr. ① <i>Order Number</i> No de cde.
148 001	29 – 37	103	16,0	268 011
148 002	36 – 44	103	16,0	268 012
148 003	43 – 54	103	20,0	268 013
148 004	53 – 66	103	20,0	268 014
148 005	65 – 83	103	20,0	268 015
148 006	82 – 103	103	30,0	268 016
148 007	100 – 130	103	30,0	268 017
148 007	125 – 155	103	30,0	268 018
148 009	150 – 205	103	30,0	268 018

Mit diesen Plattenhaltern können
 Bohrungen mit der 100°-Schneidenecke
 von Wendeschneidplatten CC..09T3..
 zusätzlich ausgedreht werden.

*With these insert holders bores can be
 additionally turned-out with the 100°-cut-
 ting edge of the insert CC..09T3..*

Les portes-plaquettes permettent des perç-
 ages additionnels avec l'angle de coupe de
 100° des plaquettes CC..09T3..

WOHLHAUPTER

Für Ihren Erfolg.

für Kerbzahnkörper
for serrated tool body
 pour corps crantés
148... / 349...

zum Überdrehen
for outside turning
 pour détournage

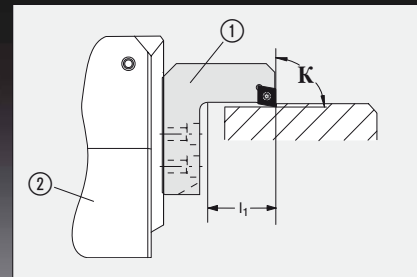

für Kerbzahnschiene ② <i>for serrated slide</i> pour guide cranté	Überdrehbereich <i>Outside turning range</i> Capacité de	WSP-Form <i>Insert form</i> Forme de détournage	Ausführung <i>Type</i> Modèle plaquette	Bestell-Nr. ① <i>Order Number</i> No de cde.	
	A		K	l_1	
148 006	32 – 55	103	90°	23,0	K 24750
148 007	65 – 95	104	90°	53,0	K 28701
148 009	90 – 145				
349 001	150 – 230				
349 002	225 – 305				
349 003	300 – 380	104	90°	53,0	K 28703
349 004	375 – 455				
349 005 + 349 014*	415 – 695				
349 006 + 349 014*	690 – 970				
349 001	150 – 230				
349 002	225 – 305				
349 003	300 – 380	104	90°	63,0	K 31892
349 004	375 – 455				
349 005 + 349 014*	415 – 695				
349 006 + 349 014*	690 – 970				

* Für leichtere Bearbeitung:
 Ausführung in Alu-Line, vernickelt
 (Best.-Nr. 349 015)

* For lighter operations (pre-finishing):
 design in Alu-Line, hard nickel-coated.
 (Order No. 349 015)

* Pour travaux légers :
 Version Alu-Line, revêtu nickel
 (No de cde. 349 015)

für DigiBore Kerbzahnschiene
 for DigiBore serrated slides
 pour DigiBore guides crantés



zum Ausdrehen, WSP-Form 103, Anstellwinkel 92°
 for boring, insert form 103, approach angles 92°
 pour alésage, forme de plaquette 103, angles d'attaque 92°

für Werkzeuge ① for boring tools pour outils d'alésage	Ausdrehbereich Boring range Capacité d'alésage			WSP-Form Insert form Forme de plaquette	Bestell-Nr. ② Order Number No de cde.	
	A	X ₂	X ₁			
501 054	68 – 96	16	32,5	103	92°	502 063
501 055	96 – 124	16	32,5			
501 056	125 – 152	16	32,5			
501 058	152 – 180	22	38,5			
501 059	180 – 208	22	38,5			

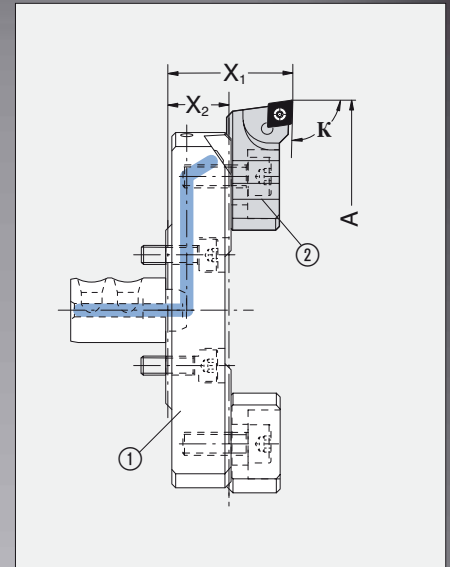

Plattenhalter Überdrehen
 Insert holder outside turning
 Porte-plaquette détourage

für Werkzeuge ① for boring tools pour outils d'alésage	Ausdrehbereich Boring range Capacité d'alésage					WSP-Form Insert form Forme de plaquette	Bestell-Nr. ② Order Number No de cde.	
	A	X ₂	X ₁	l ₁	D _{max.}			
501 055	2 – 30	16	73	55	101	101	92°	K31523
501 056	30 – 58	16	73	55	129			
501 058	58 – 86	22	79	55	157			
501 059	86 – 114	22	79	55	185			

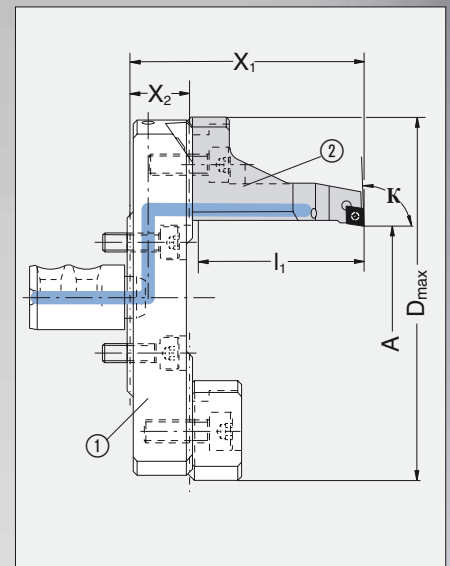

WOHLHAUPTER

Für Ihren Erfolg.

für Feindrehwerkzeuge
for precision boring tools
 pour outils d'alésage de très haute précision
310... / 264... / 364...

zum Ausdrehen, WSP-Form 20, Anstellwinkel 30° / 45°
for boring, insert form 20, approach angles 30° / 45°
 pour alésage, forme de plaquette 20, angles d'attaque 30° / 45°

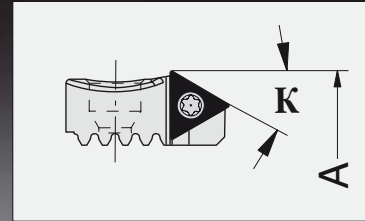

für Werkzeuge <i>for boring tools</i> pour outils d'alésage	Ausdrehbereich <i>Boring range</i> Capacité d'alésage A	WSP-Form <i>Insert form</i> Forme de plaquette	Ausführung <i>Type</i> Modèle K	Bestell-Nr. <i>Order Number</i> No de cde.
310 001	34,0 – 42,0			
364 033	39,0 – 51,5			
310 003 / 264 003	41,0 – 52,0	20	30°	K 26950
364 034	48,0 – 63,5			
264 004	51,0 – 64,0			
310 004	51,0 – 64,0			
264 045 / 364 045	63,0 – 81,0			
264 046 / 364 046	80,0 – 101,0			
364 047	98,0 – 128,0			
364 048	123,0 – 165,5			
364 049	160,5 – 203,0			
148 007 + 337 017	98,0 – 153,0	20	30°	K 25275
148 009 + 337 017	148,0 – 203,0			
349 001 + 337 017	198,0 – 278,0			
349 002 + 337 017	273,0 – 353,0			
349 003 + 337 017	348,0 – 428,0			
349 004 + 337 017	423,0 – 503,0			
349 005 + 349 014 + 337 017	463,0 – 743,0			
349 006 + 349 014 + 337 017	738,0 – 1018,0			
310 001	34,7 – 42,7			
364 033	39,7 – 52,2			
310 003 / 264 003	41,7 – 52,2	20	45°	K 19504
364 034	49,4 – 64,9			
264 004	51,7 – 64,7			
310 004	51,2 – 64,2			
264 045 / 364 045	63,2 – 81,2			
264 046 / 364 046	80,2 – 101,2			
364 047	98,2 – 128,2			
364 048	123,2 – 165,7			
364 049	160,7 – 203,2			
148 007 + 337 017	98,2 – 153,2	20	45°	K 19506
148 009 + 337 017	148,2 – 203,2			
349 001 + 337 017	198,2 – 278,2			
349 002 + 337 017	273,2 – 353,2			
349 003 + 337 017	348,2 – 428,2			
349 004 + 337 017	423,2 – 503,2			
349 005 + 349 014 + 337 017	463,2 – 743,2			
349 006 + 349 014 + 337 017	738,2 – 1018,2			

für Feindrehwerkzeuge
for precision boring tools
 pour outils d'alésage de très haute précision
310... / 264... / 364...

zum Ausdrehen, WSP-Form 20, Anstellwinkel 60°
for boring, insert form 20, approach angles 60°
 pour alésage, forme de plaquette 20, angles d'attaque 60°

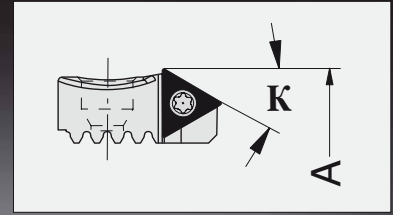

für Werkzeuge <i>for boring tools</i> pour outils d'alésage	Ausdrehbereich <i>Boring range</i> Capacité d'alésage A	WSP-Form <i>Insert form</i> Forme de plaquette	Ausführung <i>Type</i> Modèle K	Bestell-Nr. <i>Order Number</i> No de cde.
310 001	35,0 – 43,0			
364 033	40,0 – 52,5			
310 003 / 264 003	42,0 – 53,0	20	60°	K 19505
364 034	49,0 – 64,5			
264 004	52,0 – 65,0			
310 004	52,0 – 65,0			
264 045 / 364 045	64,0 – 82,0			
264 046 / 364 046	81,0 – 102,0			
364 047	99,0 – 129,0			
364 048	124,0 – 166,5			
364 049	161,5 – 204,0			
148 007 + 337 017	99,0 – 154,0	20	60°	K 19507
148 009 + 337 017	149,0 – 204,0			
349 001 + 337 017	199,0 – 279,0			
349 002 + 337 017	274,0 – 354,0			
349 003 + 337 017	349,0 – 429,0			
349 004 + 337 017	424,0 – 504,0			
349 005 + 349 014 + 337 017	464,0 – 744,0			
349 006 + 349 014 + 337 017	739,0 – 1019,0			

WOHLHAUPTER

Für Ihren Erfolg.

zum Ausdrehen, WSP-Form 101, Anstellwinkel 15° / 30°
for boring, insert form 101, approach angles 15° / 30°
pour alésage, forme de plaquette 101, angles d'attaque 15° / 30°

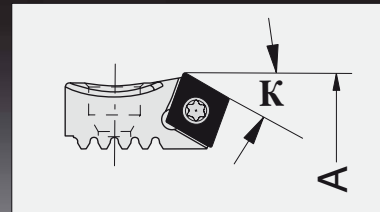

für Werkzeuge for boring tools pour outils d'alésage	Ausdrehbereich Boring range Capacité d'alésage A	WSP-Form Insert form Forme de plaquette	Ausführung Type Modèle K	Bestell-Nr. Order Number No de cde.
310 001	34,0 – 42,0			
364 033	39,0 – 51,5			
310 003 / 264 003	41,0 – 52,0	101	15°	K 26067
364 034	48,0 – 63,5			
264 004	51,0 – 64,0			
310 004	51,4 – 64,4			
264 045 / 364 045	63,4 – 81,4			
264 046 / 364 046	80,4 – 101,4			
364 047	98,4 – 128,4			
364 048	123,4 – 165,9			
364 049	160,9 – 203,4			
148 007 + 337 017	98,4 – 153,4	101	15°	K 21098
148 009 + 337 017	148,4 – 203,4			
349 001 + 337 017	198,4 – 278,4			
349 002 + 337 017	273,4 – 353,4			
349 003 + 337 017	348,4 – 428,4			
349 004 + 337 017	423,4 – 503,4			
349 005 + 349 014 + 337 017	463,4 – 743,4			
349 006 + 349 014 + 337 017	738,4 – 1018,4			
310 001	34,5 – 42,5			
364 033	39,5 – 52,0			
310 003 / 264 003	41,5 – 52,5	101	30°	K 26800
364 034	48,5 – 64,0			
264 004	51,5 – 64,5			
310 004	51,5 – 64,5			
264 045 / 364 045	63,5 – 81,5			
264 046 / 364 046	80,5 – 101,5			
364 047	98,5 – 128,5			
364 048	123,5 – 166,0			
364 049	161,0 – 203,5			
148 007 + 337 017	98,5 – 153,5	101	30°	K 28540
148 009 + 337 017	148,5 – 203,5			
349 001 + 337 017	198,5 – 278,5			
349 002 + 337 017	273,5 – 353,5			
349 003 + 337 017	348,5 – 428,5			
349 004 + 337 017	423,5 – 503,5			
349 005 + 349 014 + 337 017	463,5 – 743,5			
349 006 + 349 014 + 337 017	738,5 – 1018,5			

für Feindrehwerkzeuge
for precision boring tools
 pour outils d'alésage de très haute précision
310... / 264... / 364...

zum Ausdrehen, WSP-Form 101, Anstellwinkel 45°
for boring, insert form 101, approach angles 45°
 pour alésage, forme de plaquette 101, angles d'attaque 45°

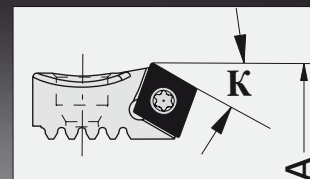

für Werkzeuge <i>for boring tools</i> pour outils d'alésage	Ausdrehbereich <i>Boring range</i> Capacité d'alésage A	WSP-Form <i>Insert form</i> Forme de plaquette	Ausführung <i>Type</i> Modèle K	Bestell-Nr. <i>Order Number</i> No de cde.
310 001	34,5 – 42,5			
364 033	39,5 – 52,0			
310 003 / 264 003	41,5 – 52,5	101	45°	K 26065
364 034	48,5 – 64,0			
264 004	51,5 – 64,5			
310 004	51,5 – 64,5			
264 045 / 364 045	63,5 – 81,5			
264 046 / 364 046	80,5 – 101,5			
364 047	98,5 – 128,5			
364 048	123,5 – 166,0			
364 049	161,0 – 203,5			
148 007 + 337 017	98,5 – 153,5	101	45°	K 25888
148 009 + 337 017	148,5 – 203,5			
349 001 + 337 017	198,5 – 278,5			
349 002 + 337 017	273,5 – 353,5			
349 003 + 337 017	348,5 – 428,5			
349 004 + 337 017	423,5 – 503,5			
349 005 + 349 014 + 337 017	463,5 – 743,5			
349 006 + 349 014 + 337 017	738,5 – 1018,5			

zum Ausdrehen, WSP-Form 101, Anstellwinkel 90°
for boring, insert form 101, approach angles 90°
 pour alésage, forme de plaquette 101, angles d'attaque 90°

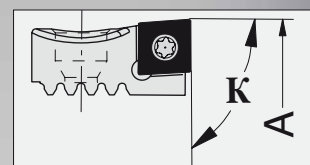

für Werkzeuge <i>for boring tools</i> pour outils d'alésage	Ausdrehbereich <i>Boring range</i> Capacité d'alésage A	WSP-Form <i>Insert form</i> Forme de plaquette	Ausführung <i>Type</i> Modèle K	Bestell-Nr. <i>Order Number</i> No de cde.
364 031	24,5 – 29,5			
310 001	29,0 – 37,0	101	90°	K 32944
364 032	29,0 – 38,5			
364 033	38,0 – 50,5	101	90°	K 32822
310 002	36,0 – 44,0			
310 003 / 264 003	43,0 – 54,0	101	90°	K 25618
364 034	50,0 – 65,5			
264 004	43,0 – 54,0			
310 004	53,0 – 66,0			
264 045 / 364 045	65,0 – 83,0			
264 046 / 364 046	82,0 – 103,0			
364 047	100,0 – 130,0			
364 048	125,0 – 167,5			
364 049	162,5 – 205,0			
148 007 + 337 017	100,0 – 155,0	101	90°	K 30260
148 009 + 337 017	150,0 – 205,0			
349 001 + 337 017	200,0 – 280,0			
349 002 + 337 017	275,0 – 355,0			
349 003 + 337 017	350,0 – 430,0			
349 004 + 337 017	425,0 – 505,0			
349 005 + 349 014 + 337 017	465,0 – 745,0			
349 006 + 349 014 + 337 017	740,0 – 1020,0			

zum Ausdrehen, WSP-Form 101 / 103, Anstellwinkel 95°
 for boring, insert form 101 / 103, approach angles 95°
 pour alésage, forme de plaquette 101 / 103, angles d'attaque 95°

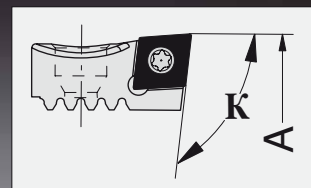

für Werkzeuge for boring tools pour outils d'alésage	Ausdrehbereich Boring range Capacité d'alésage A	WSP-Form Insert form Forme de plaquette	Ausführung Type Modèle K	Bestell-Nr. Order Number No de cde.
310 001	35,0 – 43,0			
364 033	40,0 – 52,5			
310 003 / 264 003	42,0 – 53,0	101	95°	K 22718
364 034	49,0 – 64,5			
264 004	52,0 – 65,0			
310 004	53,0 – 66,0			
264 045 / 364 045	65,0 – 83,0			
264 046 / 364 046	82,0 – 103,0			
364 047	100,0 – 130,0			
364 048	125,0 – 167,5			
364 049	162,5 – 205,0			
148 007 + 337 017	100,0 – 155,0	101	95°	K 26600
148 009 + 337 017	150,0 – 205,0			
349 001 + 337 017	200,0 – 280,0			
349 002 + 337 017	275,0 – 355,0			
349 003 + 337 017	350,0 – 430,0			
349 004 + 337 017	425,0 – 505,0			
349 005 + 349 014 + 337 017	465,0 – 745,0			
349 006 + 349 014 + 337 017	740,0 – 1020,0			
310 004	51,4 – 64,4			
264 045 / 364 045	63,4 – 81,4			
264 046 / 364 046	80,4 – 101,4			
364 047	98,4 – 128,4			
364 048	123,4 – 165,9			
364 049	160,9 – 203,4			
148 007 + 337 017	98,4 – 153,4	103	95°	K 28029
148 009 + 337 017	148,4 – 203,4			
349 001 + 337 017	198,4 – 278,4			
349 002 + 337 017	273,4 – 353,4			
349 003 + 337 017	348,4 – 428,4			
349 004 + 337 017	423,4 – 503,4			
349 005 + 349 014 + 337 017	463,4 – 743,4			
349 006 + 349 014 + 337 017	738,4 – 1018,4			

für Feindrehwerkzeuge
for precision boring tools
 pour outils d'alésage de très haute précision
310... / 264... / 364.../337...

zum Ausdrehen, WSP-Form 20, Anstellwinkel 85°
for boring, insert form 20, approach angles 85°
 pour alésage, forme de plaquette 20, angles d'attaque 85°

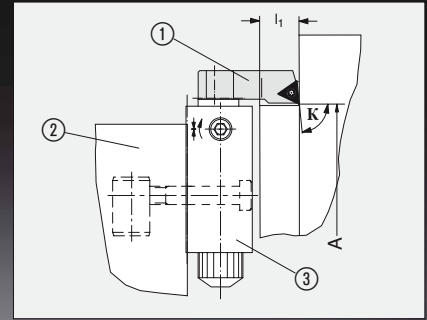

für Werkzeuge ② ③ <i>for boring tools</i> pour outils d'alésage	Überdrehbereich <i>Outside turning range</i> Capacité de détourage A	WSP-Form <i>Insert form</i> Forme de plaquette	Ausführung <i>Type</i> Modèle K l₁	Bestell-Nr. ① <i>Order Number</i> No de cde.
310 004	18,0 – 31,0			
264 045 / 364 045	30,0 – 48,0			
264 046 / 364 046	47,0 – 68,0			
364 047	65,0 – 95,0			
364 048	90,0 – 132,5			
364 049	127,5 – 170,0			
148 007 + 337 017	65,0 – 120,0	20	85° 18	K 19346
148 009 + 337 017	115,0 – 170,0			
349 001 + 337 017	165,0 – 245,0			
349 002 + 337 017	240,0 – 320,0			
349 003 + 337 017	315,0 – 395,0			
349 004 + 337 017	390,0 – 470,0			
349 005 + 349 014 + 337 017	430,0 – 710,0			
349 006 + 349 014 + 337 017	705,0 – 985,0			

WOHLHAUPTER

Für Ihren Erfolg.

zum Ausdrehen, WSP-Form 37, Anstellwinkel 60°
 for boring, insert form 37, approach angles 60°
 pour alésage, forme de plaquette 37, angles d'attaque 60°

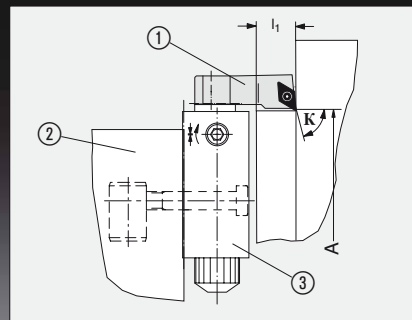

für Werkzeuge ② ③ for boring tools pour outils d'alésage	Überdrehbereich Outside turning range Capacité de détourage A	WSP-Form Insert form Forme de plaquette 37	Ausführung Type Modèle		Bestell-Nr. ① Order Number No de cde. K 25066
			K	l ₁	
310 004	18,0 – 31,0				
264 045 / 364 045	30,0 – 48,0				
264 046 / 364 046	47,0 – 68,0				
364 047	65,0 – 95,0				
364 048	90,0 – 132,5				
364 049	127,5 – 170,0				
148 007 + 337 017	65,0 – 120,0				
148 009 + 337 017	115,0 – 170,0				
349 001 + 337 017	165,0 – 245,0				
349 002 + 337 017	240,0 – 320,0				
349 003 + 337 017	315,0 – 395,0				
349 004 + 337 017	390,0 – 470,0				
349 005 + 349 014 + 337 017	430,0 – 710,0				
349 006 + 349 014 + 337 017	705,0 – 985,0				
			60°	24	

für Feindrehwerkzeuge
for precision boring tools
 pour outils d'alésage de très haute précision
310... / 264... / 364.../337...

zum Ausdrehen, WSP-Form 101, Anstellwinkel 85°
for boring, insert form 101, approach angles 85°
 pour alésage, forme de plaquette 101, angles d'attaque 85°

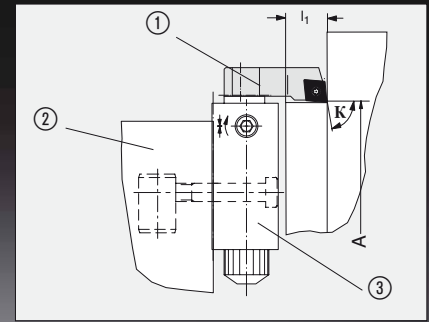

für Werkzeuge ② ③ <i>for boring tools</i> pour outils d'alésage	Übergrenzbereich <i>Outside turning range</i> Capacité de détourage A	WSP-Form <i>Insert form</i> Forme de plaquette	Ausführung <i>Type</i> Modèle		Bestell-Nr. ① <i>Order Number</i> No de cde.
			K	l₁	
310 004	18,0 – 31,0				
264 045 / 364 045	30,0 – 48,0				
264 046 / 364 046	47,0 – 68,0				
364 047	65,0 – 95,0				
364 048	90,0 – 132,5				
364 049	127,5 – 170,0				
148 007 + 337 017	65,0 – 120,0	101	85°	18	K 19344
148 009 + 337 017	115,0 – 170,0				
349 001 + 337 017	165,0 – 245,0				
349 002 + 337 017	240,0 – 320,0				
349 003 + 337 017	315,0 – 395,0				
349 004 + 337 017	390,0 – 470,0				
349 005 + 349 014 + 337 017	430,0 – 710,0				
349 006 + 349 014 + 337 017	705,0 – 985,0				
310 004	18,0 – 31,0				
264 045 / 364 045	30,0 – 48,0				
264 046 / 364 046	47,0 – 68,0				
364 047	65,0 – 95,0				
364 048	90,0 – 132,5				
364 049	127,5 – 170,0				
148 007 + 337 017	65,0 – 120,0	101	85°	22	K 31045
148 009 + 337 017	115,0 – 170,0				
349 001 + 337 017	165,0 – 245,0				
349 002 + 337 017	240,0 – 320,0				
349 003 + 337 017	315,0 – 395,0				
349 004 + 337 017	390,0 – 470,0				
349 005 + 349 014 + 337 017	430,0 – 710,0				
349 006 + 349 014 + 337 017	705,0 – 985,0				
310 004	18,0 – 31,0				
264 045 / 364 045	30,0 – 48,0				
264 046 / 364 046	47,0 – 68,0				
346 047	65,0 – 95,0				
364 048	90,0 – 132,5				
364 049	127,5 – 170,0				
148 007 + 337 017	65,0 – 120,0	101	85°	30	K 19705
148 009 + 337 017	115,0 – 170,0				
349 001 + 337 017	165,0 – 245,0				
349 002 + 337 017	240,0 – 320,0				
349 003 + 337 017	315,0 – 395,0				
349 004 + 337 017	390,0 – 470,0				
349 005 + 349 014 + 337 017	430,0 – 710,0				
349 006 + 349 014 + 337 017	705,0 – 985,0				

zum Ausdrehen, WSP-Form 103 / 104, Anstellwinkel 85°
for boring, insert form 103 / 104, approach angles 85°
pour alésage, forme de plaquette 103 / 104, angles d'attaque 85°

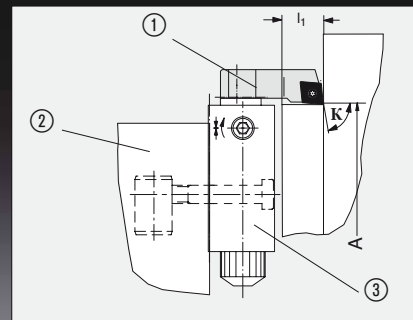

für Werkzeuge ② ③ for boring tools pour outils d'alésage	Überdrehbereich Outside turning range Capacité de détourage A	WSP-Form Insert form Forme de plaquette	Ausführung Type Modèle		Bestell-Nr. ① Order Number No de cde.				
			K	l ₁					
310 004	18,0 – 31,0								
264 045 / 364 045	30,0 – 48,0								
264 046 / 364 046	47,0 – 68,0								
364 047	65,0 – 95,0								
364 048	90,0 – 132,5								
364 049	127,5 – 170,0								
148 007 + 337 017	65,0 – 120,0	103	85°	18	K 19125				
148 009 + 337 017	115,0 – 170,0								
349 001 + 337 017	165,0 – 245,0								
349 002 + 337 017	240,0 – 320,0								
349 003 + 337 017	315,0 – 395,0								
349 004 + 337 017	390,0 – 470,0								
349 005 + 349 014 + 337 017	430,0 – 710,0								
349 006 + 349 014 + 337 017	705,0 – 985,0								
310 004	18,0 – 31,0								
264 045 / 364 045	30,0 – 48,0								
264 046 / 364 046	47,0 – 68,0								
364 047	65,0 – 95,0								
364 048	90,0 – 132,5								
364 049	127,5 – 170,0								
148 007 + 337 017	65,0 – 120,0	104	85°	27	K 31574				
148 009 + 337 017	115,0 – 170,0								
349 001 + 337 017	165,0 – 245,0								
349 002 + 337 017	240,0 – 320,0								
349 003 + 337 017	315,0 – 395,0								
349 004 + 337 017	390,0 – 470,0								
349 005 + 349 014 + 337 017	430,0 – 710,0								
349 006 + 349 014 + 337 017	705,0 – 985,0								

Wohlhaupter Programm

Wohlhaupter range

Le programme Wohlhaupter

WOHLHAUPTER
Für Ihren Erfolg.

Systemwerkzeuge
System tools
Système d'outils



MULTI BORE

WOHLHAUPTER
Für Ihren Erfolg.

Spannzeuge
Clamping tools
Outils de serrage

- HKK DIN 6003
- DIN 60 071-A/-AD/-B
- DIN 6001
- MAS-BT



WOHLHAUPTER
Für Ihren Erfolg.

Modulares Drehwerkzeugsystem
Modular Turning Tool System
Système Modulaire de Tournage

Modular turning Tool System MTS



Kundenspezifische Lösungen
Customised solutions
Solutions sur mesure



WOHLHAUPTER
Für Ihren Erfolg.

Einstechkopf **EK**
Grooving head
Tête pour exécution de gorges

Die höchstexakte Justierung für Einstechkopfmühlung.
The most-accurate adjustment for grooving operations.
Une précision maximale pour l'exécution de gorges.



WOHLHAUPTER
Für Ihren Erfolg.

Plan- und Ausdrehköpfe **UPA**
Facing and boring heads
Tête à dresser et à aléser



WOHLHAUPTER
Für Ihren Erfolg.

WOHLHAUPTER

Für Ihren Erfolg.

Wohlhaupter GmbH Präzisionswerkzeuge
Maybachstraße 4 • 72636 Frickenhausen
Postfach 1264 • 72633 Frickenhausen
Tel. (0 70 22) 408-0 • Fax (0 70 22) 408-212
Internet: www.wohlhaupter.de
E-Mail: info@wohlhaupter.de

Zertifiziertes Qualitätsmanagement – bei Wohlhaupter selbstverständlich.
Certificated Quality Management goes without saying with Wohlhaupter.
Le management de la qualité est naturellement certifié chez Wohlhaupter.



90515/11.2006 - Printed in Germany - Technische Änderungen vorbehalten. We reserve the right to technical changes. Sous réserves de modifications techniques.

Deutschland | Österreich | Schweiz

Wohlhaupter GmbH
Maybachstraße 4
72636 Frickenhausen
Germany

Telefon:
+49 (0) 7022 408-0
Email:
info@wohlhaupter.de
Web:
www.wohlhaupter.com

Europa

Allied Machine & Engineering Co. (Europe) Ltd.
93 Vantage Point
Pensnett Estate
Kingswinford
West Midlands
DY6 7FR England

Telefon:
+44 (0) 1384 400900
Email:
enquiries.eu@alliedmachine.com
Web:
www.alliedmachine.com

Vereinigte Staaten

Allied Machine & Engineering
120 Deeds Drive
Dover OH 44622
United States

Telefon:
+1 330 343 4283
Fax:
+1 330 602 3400

Allied Machine & Engineering
485 W Third Street
Dover OH 44622
United States

Telefon:
+1 330 343 4283
Fax:
+1 330 364 7666
(Engineering Dept.)

Asien

Wohlhaupter India Pvt. Ltd.
B-23, 2nd Floor
B Block Community Centre
Janakpuri, New Delhi - 110058
India

Telefon:
+91 11 41827044



日易呼 机械

GOLDEN CARBIDE PRECISION

台北市敦化南路二段40號二樓 郵遞區號: 106

上海市天鑰橋路325號嘉匯國際廣場A棟2101-2102室 郵編: 200030

台北: 886-2-2705-8448

台中: 886-4-24638159

上海: 86-21-3363-2088

北京: 86-10-8851-8900

成都: 86-28-8526-6681

長春: 86-431-8461-7085

重慶: 86-23-6757-3205

外高橋保稅庫: 86-21-5868-3075

Website: www.goldencarbide.com

www.wohlhaupter.com

90200 06.2018

Printed in Germany · Technische Änderungen vorbehalten

Holemaking Solutions for Today's Manufacturing