

風電軸承測試

<工件和加工資訊>

工件名	風電軸承
機床	MCT
孔直徑	14.5 mm
切削深度	200mm
材料	SCM440

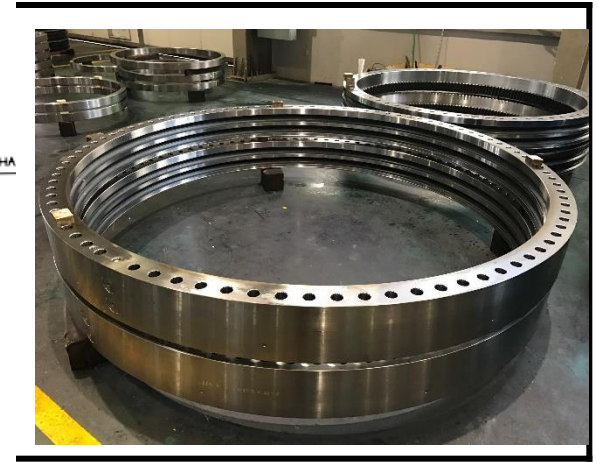
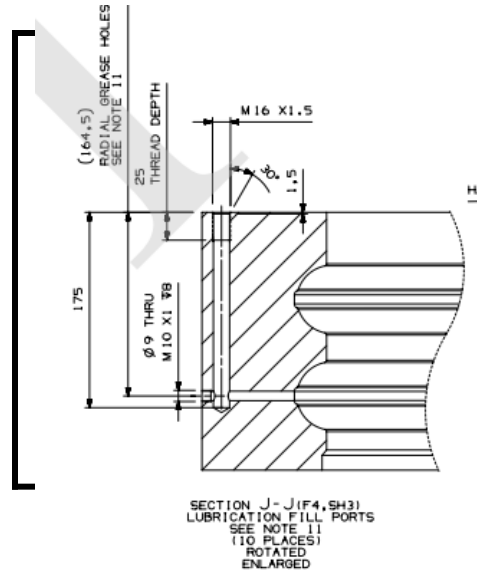

<切削參數>

品牌	WALTER/KYOCERA	AMEC
刀片形式	硬質合金	GEN3-XT-PRO
	14.5	XTP14-14.50
N (m/min)	1100/Walter 1250/TA	1500
f (mm/rev)	0.09(100)/Walter 0.18 (225)/TA	0.2 (315)
壽命	30 Hole/Competitor, 60 Hole/TA	每100孔換刀片



風電軸承測試

<工件和加工資訊>

工件名	風電軸承
機床	MCT
孔直徑	24 mm
切削深度	200mm
材料	SCM440

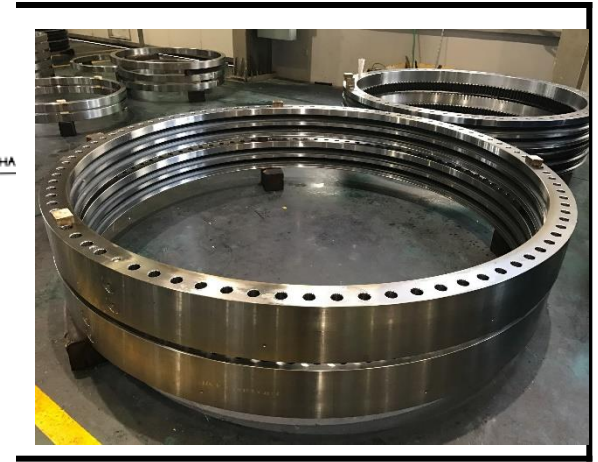
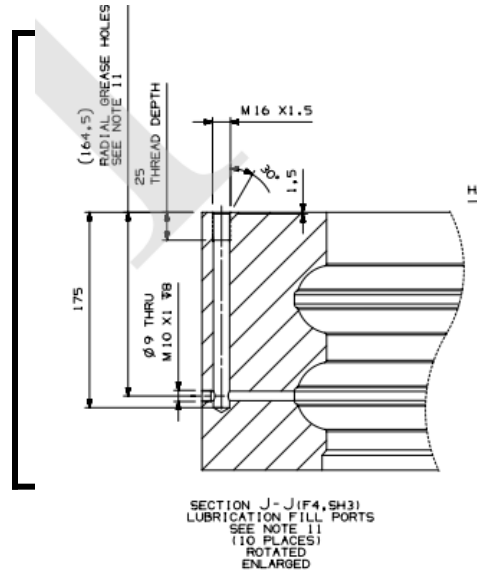

<切削參數>

品牌	WALTER/KYOCERA	AMEC
刀片形式	SOLID CARBIDE	GEN3-XT-PRO
	24	XTP24-24.00
N (m/min)	1100/Walter 1250/TA	1500
f (mm/rev)	0.09(100)/Walter 0.18 (225)/TA	0.2 (315)
壽命	35 Hole/Competitor, 60 Hole/TA	每100孔換刀片



